



# Service Manual

## Hydroject® 3010

### Preface

This publication provides the service technician with information for troubleshooting, testing, and repair of the Hydroject.

REFER TO THE HYDROJECT OPERATOR'S MANUAL FOR OPERATING, MAINTENANCE AND ADJUSTMENT INSTRUCTIONS. Space is provided in Chapter 2 of this book to insert the Operator's Manual and Parts Catalog for your machine. A replacement Operator's Manual is available by sending the complete Model and Serial Number of the machine to:

The Toro Company  
8111 Lyndale Avenue South  
Bloomington, MN 55420

The Toro Company reserves the right to change product specifications or this publication without notice.



**This safety symbol means DANGER, WARNING, or CAUTION, PERSONAL SAFETY INSTRUCTION. When you see this symbol, carefully read the instructions that follow. Failure to obey the instructions may result in personal injury.**

**NOTE:** A NOTE will give general information about the correct operation, maintenance, service, testing or repair of the machine.

**IMPORTANT:** The IMPORTANT notice will give important instructions which must be followed to prevent damage to systems or components on the machine.





# Table Of Contents

---

## Chapter 1 - Safety

Safety Instructions . . . . . 1 - 1

## Chapter 2 - Product Records and Manuals

Product Records . . . . . 2 - 1  
Maintenance . . . . . 2 - 1  
Equivalents and Conversions . . . . . 2 - 2  
Torque Specifications . . . . . 2 - 3

## Chapter 3 - Engine

Specifications . . . . . 3 - 1  
Repairs . . . . . 3 - 2  
Kohler Engine Service Manual

## Chapter 4 - Hydraulic System

Specifications . . . . . 4 - 2  
General Information . . . . . 4 - 3  
Hydraulic Diagram . . . . . 4 - 6  
Special Tools . . . . . 4 - 7  
Troubleshooting . . . . . 4 - 8  
Testing . . . . . 4 - 9  
Adjustments . . . . . 4 - 11  
Repairs . . . . . 4 - 14

## Chapter 5 - Electrical System

Wiring Schematics and Diagrams . . . . . 5 - 2  
Special Tools . . . . . 5 - 5  
Troubleshooting . . . . . 5 - 7  
Testing . . . . . 5 - 15  
Repairs . . . . . 5 - 24

## Chapter 6 - Water System

Specifications . . . . . 6 - 2  
Water System Schematic . . . . . 6 - 3  
Special Tools . . . . . 6 - 4  
Troubleshooting . . . . . 6 - 9  
Testing . . . . . 6 - 12  
Adjustments . . . . . 6 - 18  
Repairs . . . . . 6 - 20

## Chapter 7 - Wheels, Steering and Brakes

Adjustments . . . . . 7 - 2  
Repairs . . . . . 7 - 3

## Chapter 8 - Electrical Diagrams

Schematic . . . . . 8 - 3  
Main Harness . . . . . 8 - 4  
Main Wiring Diagram . . . . . 8 - 5  
Control Panel Harness . . . . . 8 - 6  
Control Panel Wiring Diagram . . . . . 8 - 7  
Tiller Harness and Wiring Diagram . . . . . 8 - 8





## Table of Contents

SAFETY INSTRUCTIONS .....	1	Maintenance and Service .....	3
Before Operating .....	1	SAFETY AND INSTRUCTION DECALS .....	4
While Operating .....	2		

## Safety Instructions

Although hazard control and accident prevention partially are dependent upon the design and configuration of the machine, these factors are also dependent upon the awareness, concern, and proper training of the personnel involved in the operation, transport, maintenance, and storage of the machine. Improper use or maintenance of the machine can result in injury or death. To reduce the potential for injury or death, comply with the following safety instructions.



### Before Operating

1. Read and understand the contents of this manual before starting and operating the machine. Become familiar with all controls and know how to stop quickly. A free replacement manual is available by sending complete Model and Serial Numbers to:

The Toro Company  
8111 Lyndale Avenue South  
Bloomington, Minnesota 55420

Use the Model and Serial Number when referring to your machine. If you have questions about this Service Manual, please contact:

The Toro Company  
Commercial Service Department  
8111 Lyndale Avenue South  
Bloomington, Minnesota 55420

2. Never allow children to operate the machine. Do not allow adults to operate machine without proper instruction. Only trained operators who have read this manual should operate this machine.

3. Never operate the machine when under the influence of drugs or alcohol.

4. Before attempting to start engine engage parking brake.

5. Remove all debris or other objects that might interfere with operation. Keep all bystanders away from the work area.

6. Keep all shields and safety devices in place. If a shield, safety device or decal is defective or damaged, repair or replace it before operation is commenced. Also tighten any loose nuts, bolts and screws to assure machine is in safe operating condition.

7. Do not operate machine while wearing sandals, tennis shoes, sneakers or shorts. Also, do not wear loose fitting clothing which could get caught in moving parts. Always wear long pants and substantial shoes. Wearing safety glasses, safety shoes, ear protection and a helmet is advisable and required by some local ordinances and insurance regulations.

8. Fill fuel tank with gasoline before starting the engine. Avoid spilling gasoline. Since gasoline is flammable, handle it carefully.

- A. Use an approved gasoline container.
- B. Do not fill tank while engine is hot or running.
- C. Do not smoke while handling gasoline.

D. Fill fuel tank outdoors and up to about one inch (25 mm) from top of the tank, not the filler neck.

E. Wipe up any spilled gasoline.

9. Check interlock switches daily for proper operation. If a switch fails, replace it before operating the machine. The interlock system is for your protection, so do not bypass it. Replace all interlock switches every two years.

---

## While Operating

10. **DON'T TAKE AN INJURY RISK!** When a person or pet appears unexpectedly in or near the WORKING area, **STOP AERATING.**

11. Keep hands and feet away from nozzle and roller area. High velocity water jets can penetrate hands and feet. Penetration by the high velocity water jets can cause serious personal injury. If accidental penetration occurs, seek medical attention immediately.

12. Never use chemicals in the water supply system.

13. Do not operate water injection system on concrete or asphalt because water jets will permanently damage these surfaces.

14. Start engine with parking brake engaged.

15. Do not run the engine in a confined area without adequate ventilation. Exhaust fumes are hazardous and could possibly be deadly.

16. Using the machine demands attention, and to prevent loss of control:

A. Use only in daylight or when there is good artificial light.

B. Watch for holes or other hidden hazards.

C. Do not transport machine close to a sand trap, ditch, creek or other hazard.

17. If the machine starts to vibrate abnormally, shut the engine off. Remove wires from spark plugs to prevent possibility of accidental starting. Check machine for damage and defective parts. Repair any damage before restarting the engine and operating the machine.

18. Do not touch engine or muffler while engine is running or soon after it is stopped. These areas could be hot enough to cause a burn.

19. Before leaving the operator's position—behind handle—engage parking brake.

20. When leaving the machine unattended, engage parking brake, shut engine OFF and remove key from ignition switch.

---

## Maintenance

21. Disconnect wires from spark plugs to prevent accidental starting of the engine when servicing, adjusting or storing the machine.

22. If machine must be tipped to perform maintenance or an adjustment, close fuel shut-off valve, drain gasoline from fuel tank, oil from crankcase and remove battery.

23. To reduce potential fire hazard, keep the engine free of excessive grease, grass, leaves and accumulations of dirt.

24. Be sure machine is in safe operating condition by keeping nuts, bolts and screws tight. Check all bolts and nuts frequently to be sure they are tightened to specification.

25. If the engine must be running to perform a maintenance adjustment, keep hands, feet, clothing and other parts of the body away from any moving parts.

26. Make sure all hydraulic line connectors are tight, and all hydraulic hoses and lines are in good condition before applying pressure to the system.

27. Keep body and hands away from pin hole leaks or nozzles that eject water or hydraulic fluid under high pressure. Use paper or cardboard, not hands, to search for leaks. Hydraulic fluid or water escaping under pressure can have sufficient force to penetrate skin and do serious damage. If either of these fluids are ejected into the skin they must be surgically removed within a few hours by a doctor familiar with this form of injury or gangrene may result.

28. Before disconnecting or performing any work on the hydraulic oil system, all pressure in system must be relieved by stopping engine and opening by-pass valve.

29. Make sure all water line connectors are tight, and all hoses and lines are in good condition before applying pressure to the system.

- 30.** Before disconnecting or performing any work on the water system, all pressure in system must be relieved by stopping engine and opening bleed valve. Opening the bleed valve allows any trapped water to escape from the system and also allows the accumulator piston to move to the bottom of the accumulator cylinder.
- 31.** The accumulator in this machine contains high pressure dry nitrogen. Accumulator servicing requires special tools and precautions. Accumulators do not contain user serviceable components. Improper accumulator servicing can cause dismemberment or death. Do not attempt to disassemble a accumulator, have this work done by a Authorized Toro Distributor.
- 32.** Do not overspeed the engine by changing governor settings. To be sure of safety and accuracy, have an Authorized TORO Distributor check maximum engine speed with a tachometer.
- 33.** Engine must be shut off before checking oil or adding oil to the crankcase.
- 34.** Allow engine to cool before storing machine in any enclosure such as a garage or storage shed. Make sure the fuel tank is empty if machine is to be stored in excess of 30 days. Do not store machine near any open flame or where gasoline fumes may be ignited by a spark. Always store gasoline in a safety approved, red metal container.
- 35.** When storing or transporting machine (trailer), make sure fuel shut-off valve is closed.
- 36.** Perform only those maintenance instructions described in this manual. If major repairs are ever needed or assistance is desired, contact an Authorized Toro Distributor. To ensure optimum performance and safety, always purchase genuine TORO replacement parts and accessories to keep the Toro all TORO. NEVER USE "WILL-FIT" REPLACEMENT PARTS AND ACCESSORIES MADE BY OTHER MANUFACTURERS. Look for the TORO logo to assure genuineness. Using unapproved replacement parts and accessories could void the warranty of The Toro Company.

# Safety and Instruction Decals

Numerous safety and instruction decals are affixed to the Hydroject 3010. If any decal becomes illegible or damaged, install a new decal. Part numbers for replacement decals are listed in your Parts Catalog. Order replacement decals from your authorized Toro Distributor.



# Product Records and Maintenance

## Table of Contents

PRODUCT RECORDS .....	1	Standard Torque for Dry, Zinc Plated and	
MAINTENANCE .....	1	Steel Fasteners (Inch Series) .....	4
EQUIVALENTS AND CONVERSIONS .....	2	Standard Torque for Dry, Zinc Plated and	
Decimal and Millimeter Equivalents .....	2	Steel Fasteners (Metric Fasteners) .....	5
U.S. to Metric Conversions .....	2	Other Torque Specifications .....	6
TORQUE SPECIFICATIONS .....	3	Conversion Factors .....	6
Fastener Identification .....	3		

## Product Records

Insert Operator’s Manual and Parts Catalog for your Hydroject 3010 at the end of this chapter. Additionally, if any optional equipment or accessories have been installed to your Hydroject, insert the Installation Instructions, Operator’s Manuals and Parts Catalogs for those options at the end of this chapter.

## Maintenance

Maintenance procedures and recommended service intervals for the Hydroject 3010 covered in the Operator’s Manual. Refer to that publication when performing regular equipment maintenance. Refer to the Engine Operator’s Manual for additional engine specific maintenance procedures.

# Equivalents and Conversions

## Decimal and Millimeter Equivalents

Fractions	Decimals	mm	Fractions	Decimals	mm		
	1/64	0.015625	— 0.397	33/64	0.515625	— 13.097	
1/32	—	0.03125	— 0.794	17/32	—	0.53125	— 13.494
	3/64	0.046875	— 1.191	35/64	0.546875	— 13.891	
1/16	—	0.0625	— 1.588	9/16	—	0.5625	— 14.288
	5/64	0.078125	— 1.984	37/64	0.578125	— 14.684	
	3/32	0.09375	— 2.381	19/32	—	0.59375	— 15.081
	7/64	0.109275	— 2.778	39/64	0.609375	— 15.478	
1/8	—	0.1250	— 3.175	5/8	—	0.6250	— 15.875
	9/64	0.140625	— 3.572	41/64	0.640625	— 16.272	
	5/32	0.15625	— 3.969	21/32	—	0.65625	— 16.669
	11/64	0.171875	— 4.366	43/64	0.671875	— 17.066	
3/16	—	0.1875	— 4.762	11/16	—	0.6875	— 17.462
	13/64	0.203125	— 5.159	45/64	0.703125	— 17.859	
	7/32	0.21875	— 5.556	23/32	—	0.71875	— 18.256
	15/64	0.234375	— 5.953	47/64	0.734375	— 18.653	
1/4	—	0.2500	— 6.350	3/4	—	0.7500	— 19.050
	17/64	0.265625	— 6.747	49/64	0.765625	— 19.447	
	9/32	0.28125	— 7.144	25/32	—	0.78125	— 19.844
	19/64	0.296875	— 7.541	51/64	0.796875	— 20.241	
5/16	—	0.3125	— 7.938	13/16	—	0.8125	— 20.638
	21/64	0.328125	— 8.334	53/64	0.828125	— 21.034	
	11/32	0.34375	— 8.731	27/32	—	0.84375	— 21.431
	23/64	0.359375	— 9.128	55/64	0.859375	— 21.828	
3/8	—	0.3750	— 9.525	7/8	—	0.8750	— 22.225
	25/64	0.390625	— 9.922	57/64	0.890625	— 22.622	
	13/32	0.40625	— 10.319	29/32	—	0.90625	— 23.019
	27/64	0.421875	— 10.716	59/64	0.921875	— 23.416	
7/16	—	0.4375	— 11.112	15/16	—	0.9375	— 23.812
	29/64	0.453125	— 11.509	61/64	0.953125	— 24.209	
	15/32	0.46875	— 11.906	31/32	—	0.96875	— 24.606
	31/64	0.484375	— 12.303	63/64	0.984375	— 25.003	
1/2	—	0.5000	— 12.700	1	—	1.000	— 25.400
	<b>1 mm = 0.03937 in.</b>			<b>0.001 in. = 0.0254 mm</b>			

## U.S. to Metric Conversions

	To Convert	Into	Multiply By
<b>Linear Measurement</b>	Miles	Kilometers	1.609
	Yards	Meters	0.9144
	Feet	Meters	0.3048
	Feet	Centimeters	30.48
	Inches	Meters	0.0254
	Inches	Centimeters	2.54
	Inches	Millimeters	25.4
<b>Area</b>	Square Miles	Square Kilometers	2.59
	Square Feet	Square Meters	0.0929
	Square Inches	Square Centimeters	6.452
	Acre	Hectare	0.4047
<b>Volume</b>	Cubic Yards	Cubic Meters	0.7646
	Cubic Feet	Cubic Meters	0.02832
	Cubic Inches	Cubic Centimeters	16.39
<b>Weight</b>	Tons (Short)	Metric Tons	0.9078
	Pounds	Kilograms	0.4536
	Ounces (Avdp.)	Grams	28.3495
<b>Pressure</b>	Pounds/Sq. In.	Kilopascal	6.895
	Pounds/Sq. In.	Bar	0.069
<b>Work</b>	Foot-pounds	Newton-Meters	1.356
	Foot-pounds	Kilogram-Meters	0.1383
	Inch-pounds	Kilogram-Centimeters	1.152144
<b>Liquid Volume</b>	Quarts	Liters	0.9463
	Gallons	Liters	3.785
<b>Liquid Flow</b>	Gallons/Minute	Liters/Minute	3.785
<b>Temperature</b>	Fahrenheit	Celsius	1. Subtract 32°
			2. Multiply by 5/9

# Torque Specifications

Recommended fastener torque values are listed in the following tables. For critical applications, as determined by Toro, either the recommended torque or a torque that is unique to the application is clearly identified and specified in this Service Manual.

These Torque Specifications for the installation and tightening of fasteners shall apply to all fasteners which do not have a specific requirement identified in this Service Manual. The following factors shall be considered when applying torque: cleanliness of the fastener, use of a thread sealant (e.g. Loctite), degree of lubrication on the fastener, presence of a prevailing torque feature, hardness of the surface underneath the fastener's head or similar condition which affects the installation.

As noted in the following tables, torque values should be **reduced by 25% for lubricated fasteners** to achieve the similar stress as a dry fastener. Torque values may also have to be reduced when the fastener is threaded into aluminum or brass. The specific torque value should be determined based on the aluminum or brass material strength, fastener size, length of thread engagement, etc.

The standard method of verifying torque shall be performed by marking a line on the fastener (head or nut) and mating part, then back off fastener 1/4 of a turn. Measure the torque required to tighten the fastener until the lines match up.

---

## Fastener Identification

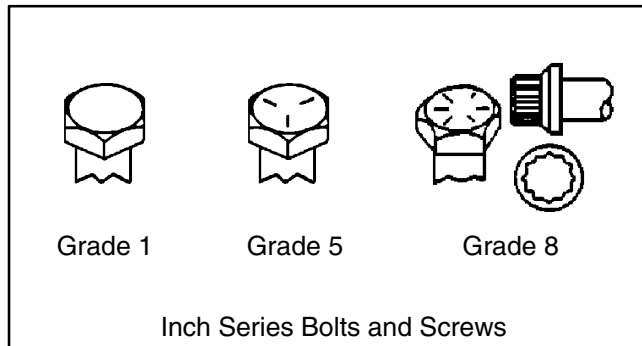

Figure 1

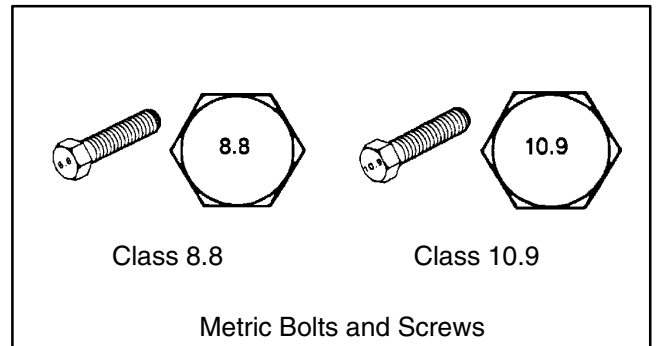

Figure 2

## Standard Torque for Dry, Zinc Plated and Steel Fasteners (Inch Series)

Thread Size	Grade 1, 5 & 8 with Thin Height Nuts	SAE Grade 1 Bolts, Screws, Studs & Sems with Regular Height Nuts (SAE J995 Grade 2 or Stronger Nuts)		SAE Grade 5 Bolts, Screws, Studs & Sems with Regular Height Nuts (SAE J995 Grade 2 or Stronger Nuts)		SAE Grade 8 Bolts, Screws, Studs & Sems with Regular Height Nuts (SAE J995 Grade 5 or Stronger Nuts)	
	in-lb	in-lb	N-cm	in-lb	N-cm	in-lb	N-cm
# 6 – 32 UNC	10 ± 2	13 ± 2	147 ± 23	15 ± 2	170 ± 20	23 ± 2	260 ± 20
# 6 – 40 UNF				17 ± 2	190 ± 20	25 ± 2	280 ± 20
# 8 – 32 UNC	13 ± 2	25 ± 5	282 ± 30	29 ± 3	330 ± 30	41 ± 4	460 ± 45
# 8 – 36 UNF				31 ± 3	350 ± 30	43 ± 4	485 ± 45
# 10 – 24 UNC	18 ± 2	30 ± 5	339 ± 56	42 ± 4	475 ± 45	60 ± 6	675 ± 70
# 10 – 32 UNF				48 ± 4	540 ± 45	68 ± 6	765 ± 70
1/4 – 20 UNC	48 ± 7	53 ± 7	599 ± 79	100 ± 10	1125 ± 100	140 ± 15	1580 ± 170
1/4 – 28 UNF	53 ± 7	65 ± 10	734 ± 113	115 ± 10	1300 ± 100	160 ± 15	1800 ± 170
5/16 – 18 UNC	115 ± 15	105 ± 17	1186 ± 169	200 ± 25	2250 ± 280	300 ± 30	3390 ± 340
5/16 – 24 UNF	138 ± 17	128 ± 17	1446 ± 192	225 ± 25	2540 ± 280	325 ± 30	3670 ± 340
	ft-lb	ft-lb	N-m	ft-lb	N-m	ft-lb	N-m
3/8 – 16 UNC	16 ± 2	16 ± 2	22 ± 3	30 ± 3	41 ± 4	43 ± 4	58 ± 5
3/8 – 24 UNF	17 ± 2	18 ± 2	24 ± 3	35 ± 3	47 ± 4	50 ± 4	68 ± 5
7/16 – 14 UNC	27 ± 3	27 ± 3	37 ± 4	50 ± 5	68 ± 7	70 ± 7	95 ± 9
7/16 – 20 UNF	29 ± 3	29 ± 3	39 ± 4	55 ± 5	75 ± 7	77 ± 7	104 ± 9
1/2 – 13 UNC	30 ± 3	48 ± 7	65 ± 9	75 ± 8	102 ± 11	105 ± 10	142 ± 14
1/2 – 20 UNF	32 ± 3	53 ± 7	72 ± 9	85 ± 8	115 ± 11	120 ± 10	163 ± 14
5/8 – 11 UNC	65 ± 10	88 ± 12	119 ± 16	150 ± 15	203 ± 20	210 ± 20	285 ± 27
5/8 – 18 UNF	75 ± 10	95 ± 15	129 ± 20	170 ± 15	230 ± 20	240 ± 20	325 ± 27
3/4 – 10 UNC	93 ± 12	140 ± 20	190 ± 27	265 ± 25	359 ± 34	375 ± 35	508 ± 47
3/4 – 16 UNF	115 ± 15	165 ± 25	224 ± 34	300 ± 25	407 ± 34	420 ± 35	569 ± 47
7/8 – 9 UNC	140 ± 20	225 ± 25	305 ± 34	430 ± 45	583 ± 61	600 ± 60	813 ± 81
7/8 – 14 UNF	155 ± 25	260 ± 30	353 ± 41	475 ± 45	644 ± 61	660 ± 60	895 ± 81

**NOTE:** Reduce torque values listed in the table above by 25% for lubricated fasteners. Lubricated fasteners are defined as threads coated with a lubricant such as oil, graphite or thread sealant such as Loctite.

**NOTE:** Torque values may have to be reduced when installing fasteners into threaded aluminum or brass. The specific torque value should be determined based on the fastener size, the aluminum or base material strength, length of thread engagement, etc.

**NOTE:** The nominal torque values listed above for Grade 5 and 8 fasteners are based on 75% of the minimum proof load specified in SAE J429. The tolerance is approximately ± 10% of the nominal torque value. Thin height nuts include jam nuts.

## Standard Torque for Dry, Zinc Plated and Steel Fasteners (Metric Fasteners)

Thread Size	Class 8.8 Bolts, Screws and Studs with Regular Height Nuts (Class 8 or Stronger Nuts)		Class 10.9 Bolts, Screws and Studs with Regular Height Nuts (Class 10 or Stronger Nuts)	
M5 X 0.8	57 ± 5 in-lb	640 ± 60 N-cm	78 ± 7 in-lb	885 ± 80 N-cm
M6 X 1.0	96 ± 9 in-lb	1018 ± 100 N-cm	133 ± 13 in-lb	1500 ± 150 N-cm
M8 X 1.25	19 ± 2 ft-lb	26 ± 3 N-m	27 ± 2 ft-lb	36 ± 3 N-m
M10 X 1.5	38 ± 4 ft-lb	52 ± 5 N-m	53 ± 5 ft-lb	72 ± 7 N-m
M12 X 1.75	66 ± 7 ft-lb	90 ± 10 N-m	92 ± 9 ft-lb	125 ± 12 N-m
M16 X 2.0	166 ± 15 ft-lb	225 ± 20 N-m	229 ± 22 ft-lb	310 ± 30 N-m
M20 X 2.5	325 ± 33 ft-lb	440 ± 45 N-m	450 ± 37 ft-lb	610 ± 50 N-m

**NOTE:** Reduce torque values listed in the table above by 25% for lubricated fasteners. Lubricated fasteners are defined as threads coated with a lubricant such as oil, graphite or thread sealant such as Loctite.

**NOTE:** Torque values may have to be reduced when installing fasteners into threaded aluminum or brass. The specific torque value should be determined based on the fastener size, the aluminum or base material strength, length of thread engagement, etc.

**NOTE:** The nominal torque values listed above are based on 75% of the minimum proof load specified in SAE J1199. The tolerance is approximately ± 10% of the nominal torque value.

## Other Torque Specifications

### SAE Grade 8 Steel Set Screws

Thread Size	Recommended Torque	
	Square Head	Hex Socket
1/4 – 20 UNC	140 ± 20 in-lb	73 ± 12 in-lb
5/16 – 18 UNC	215 ± 35 in-lb	145 ± 20 in-lb
3/8 – 16 UNC	35 ± 10 ft-lb	18 ± 3 ft-lb
1/2 – 13 UNC	75 ± 15 ft-lb	50 ± 10 ft-lb

### Wheel Bolts and Lug Nuts

Thread Size	Recommended Torque**	
	ft-lb	N-m
7/16 – 20 UNF Grade 5	65 ± 10	88 ± 14
1/2 – 20 UNF Grade 5	80 ± 10	108 ± 14
M12 X 1.25 Class 8.8	80 ± 10	108 ± 14
M12 X 1.5 Class 8.8	80 ± 10	108 ± 14

\*\* For steel wheels and non-lubricated fasteners.

### Thread Cutting Screws (Zinc Plated Steel)

Type 1, Type 23 or Type F	
Thread Size	Baseline Torque*
No. 6 – 32 UNC	20 ± 5 in-lb
No. 8 – 32 UNC	30 ± 5 in-lb
No. 10 – 24 UNC	38 ± 7 in-lb
1/4 – 20 UNC	85 ± 15 in-lb
5/16 – 18 UNC	110 ± 20 in-lb
3/8 – 16 UNC	200 ± 100 in-lb

### Thread Cutting Screws (Zinc Plated Steel)

Thread Size	Threads per Inch		Baseline Torque*
	Type A	Type B	
No. 6	18	20	20 ± 5 in-lb
No. 8	15	18	30 ± 5 in-lb
No. 10	12	16	38 ± 7 in-lb
No. 12	11	14	85 ± 15 in-lb

\* Hole size, material strength, material thickness & finish must be considered when determining specific torque values. All torque values are based on non-lubricated fasteners.

## Conversion Factors

$$\begin{aligned} \text{in-lb} \times 11.2985 &= \text{N-cm} \\ \text{ft-lb} \times 1.3558 &= \text{N-m} \end{aligned}$$

$$\begin{aligned} \text{N-cm} \times 0.08851 &= \text{in-lb} \\ \text{N-m} \times 0.7376 &= \text{ft-lb} \end{aligned}$$



**Table of Contents**

INTRODUCTION ..... 2  
SPECIFICATIONS ..... 3  
SERVICE AND REPAIRS ..... 4  
    Engine Removal and Installation ..... 4  
KOHLER ENGINE SERVICE MANUAL

# Introduction

This Chapter gives information about specifications and repair of the Kohler engine used in the ProCore 648.

General engine maintenance procedures are described in your Operator's Manual. Information on engine troubleshooting, testing, disassembly, and reassembly is identified in the Kohler Engine Service Manual that is included at the end of this section.

Most repairs and adjustments require tools which are commonly available in many service shops. Special tools are described in the Kohler Engine Service Manual. The use of some specialized test equipment is explained. However, the cost of the test equipment and the specialized nature of some repairs may dictate that the work be done at an engine repair facility.

Service and repair parts for Kohler engines are supplied through your local Kohler dealer or distributor.

# Specifications

Item	Description
Make / Designation	Kohler Command Pro 27 Carb, 4-stroke, V-Twin Air Cooled, OHV
Number of Cylinders	2
Bore x Stroke	3.3" x 2.6" (83 mm x 67 mm)
Total Displacement	44 Cubic Inches (725 cc)
Compression Ratio	9.0:1
Dry Weight (approximate)	94 Pounds (43 Kilograms)
Fuel	Unleaded, Regular Gasoline (Minimum 87 Octane)
Fuel Tank Capacity	10.5 U.S. Gallons (39.7 Liters)
Governor	Mechanical
Idle Speed (no load)	1500 – 1800 RPM
High Idle (no load)	3450 – 3550 RPM
Engine Oil	See Operator's Manual
Oil Pump	Gear driven trochoid type
Crankcase Oil Capacity	2 U.S. Quart (1.9 Liters) with filter
Starter	12 VDC

# Service and Repairs

## Engine Removal and Installation

1. Park the machine on a level surface, engage the parking brake and remove the hood.
2. Disconnect both the positive (+) and negative (-) cables from the battery. Loosen the battery clamp (Item 31) and remove the battery.
3. Drain the oil from the engine into a suitable container.
4. Disconnect the drive coupling from the clutch adapter (see Drive Coupling Removal and Installation in Water System Service).
5. Remove the water pump drive belt and hydraulic pump drive belt.
6. Disconnect the engine wiring harness connector. Disconnect and plug the fuel hose.
7. Remove four nuts (Item 24), capscrews (Item 28) and washers (Item 25) securing the engine to the frame.
8. Attach an engine lifting chain to the engine lifting straps. Connect the chain to a hoist or block and tackle and remove slack from the chain and lifting device. One person should operate the hoist or block and tackle and the other person should help guide the engine out of the frame. Remove the engine from the frame.
9. Mount the engine in an engine rebuilding stand or put it on a sturdy workbench. Before disassembling the engine, remove external accessories, such as the muffler, air cleaner, hydraulic pump clutch, hydraulic pump pulley, water pump clutch and clutch key (see Drive Coupling Removal and Installation in Water System Service).
10. To install the engine, perform steps 2 – 9 in reverse order.
11. Replace the oil filter and fill the engine with the correct oil.

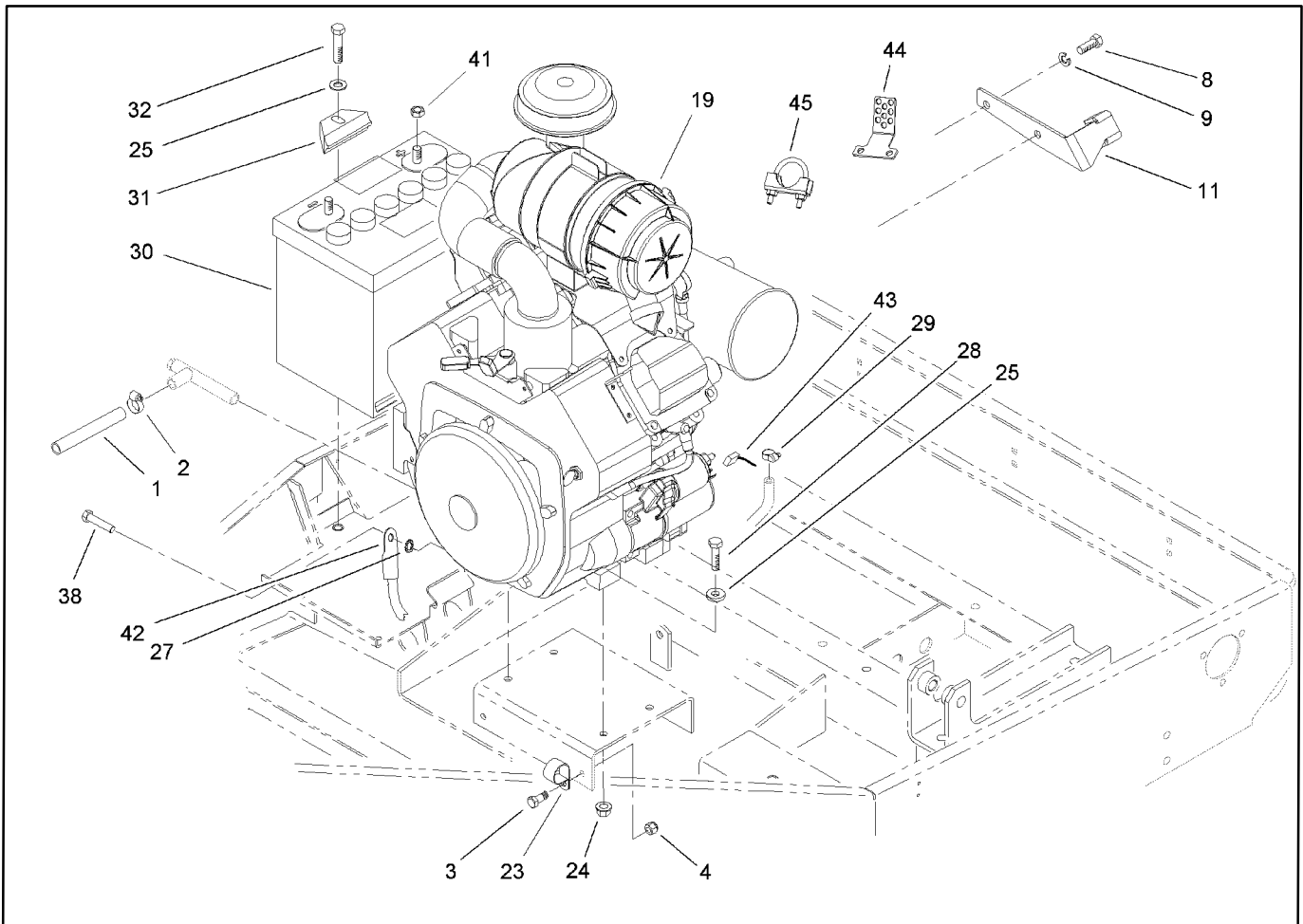

Figure 1



# Hydraulic System

## Table of Contents

SPECIFICATIONS . . . . .	2	Speed Control Adjustment . . . . .	11
GENERAL INFORMATION . . . . .	3	Transmission Neutral Adjustment . . . . .	12
Hydraulic Hose and Fitting Information . . . . .	3	Aeration Speed Adjustment . . . . .	12
Pushing or Towing . . . . .	5	Pump Drive Belt Adjustment . . . . .	13
HYDRAULIC DIAGRAM . . . . .	6	REPAIRS . . . . .	14
SPECIAL TOOLS . . . . .	7	Pump Drive Belt Replacement . . . . .	14
Hydraulic Tester . . . . .	7	Hydraulic Pump Removal and Installation . . . . .	15
TROUBLESHOOTING . . . . .	8	Pump Shaft Seal Replacement . . . . .	16
Transmission Operates in One Direction Only . . . . .	8	Pump Charge Check Valve Service . . . . .	17
System Operates Hot, Loses Power or		Pump Bypass Valve Service . . . . .	17
Will Not Operate in Either Direction . . . . .	8	Charge Pump Service . . . . .	18
TESTING . . . . .	9	Major Pump Repair . . . . .	18
Hydraulic Tests . . . . .	10	Wheel Motor Removal and Installation . . . . .	22
ADJUSTMENTS . . . . .	11	Wheel Motor Repair . . . . .	23
Traction Cable Adjustment . . . . .	11		

# Specifications

Item	Description
Pump Rated system pressure Rated system flow Charge relief pressure Oil filter	Sundstrand Series 70, BDP-10L Variable Displacement Pump 2100 PSI maximum, 1000 PSI continuous 8.5 GPM maximum at 3500 RPM 25 to 70 PSI psi at 3500 RPM 25 micron screw-on type. No by-pass
Wheel Motor	Orbit rotor type
Hydraulic Oil	See Operator's Manual
Reservoir (gear case)	Approximately 4 - 5 quarts

# General Information

## Hydraulic Hoses

Hydraulic hoses are subject to extreme conditions such as, pressure differentials during operation and exposure to weather, sun, chemicals, very warm storage conditions or mishandling during operation or maintenance. These conditions can cause damage or premature deterioration. Some hoses, such as reel motor hoses, are more susceptible to these conditions than others. Inspect the hoses frequently for signs of deterioration or damage.

When replacing a hydraulic hose, be sure that the hose is straight (not twisted) before tightening the fittings. This can be done by observing the imprint on the hose. Use two wrenches; one to hold the hose straight and one to tighten the hose swivel nut onto the fitting.



### CAUTION

Before disconnecting or performing any work on the hydraulic system, all pressure in the system must be relieved by stopping the engine and opening the bypass valve.

Keep body and hands away from pin hole leaks or nozzles that eject hydraulic fluid under high pressure. Use paper or cardboard, not hands, to search for leaks. Hydraulic fluid escaping under pressure can have sufficient force to penetrate the skin and do serious damage. If fluid is injected into the skin, it must be surgically removed within a few hours by a doctor familiar with this type of injury or gangrene may result.

## Hydraulic Fitting Installation

### O-Ring Face Seal (Fig. 2, 3)

1. Make sure both threads and sealing surfaces are free of burrs, nicks, scratches, or any foreign material.
2. Make sure the O-ring is installed and properly seated in the groove. It is recommended that the O-ring be replaced any time the connection is opened.
3. Lubricate the O-ring with a light coating of oil.
4. Put the tube and nut squarely into position on the face seal end of the fitting and tighten the nut until finger tight.
5. Mark the nut and fitting body. Hold the body with a wrench. Use another wrench to tighten the nut to the correct flats from finger tight (F.F.F.T.). The markings on the nut and fitting body will verify that the connection has been tightened.

Size	F.F.F.T.
4 (1/4 in. nominal hose or tubing)	.75 ± .25
6 (3/8 in.)	.75 ± .25
8 (1/2 in.)	.75 ± .25
10 (5/8 in.)	1.00 ± .25
12 (3/4 in.)	.75 ± .25
16 (1 in.)	.75 ± .25

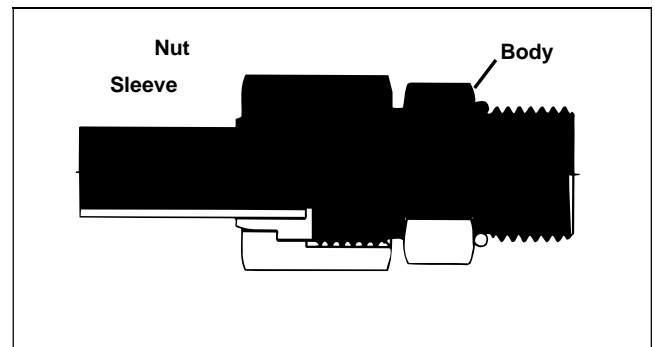

Figure 2

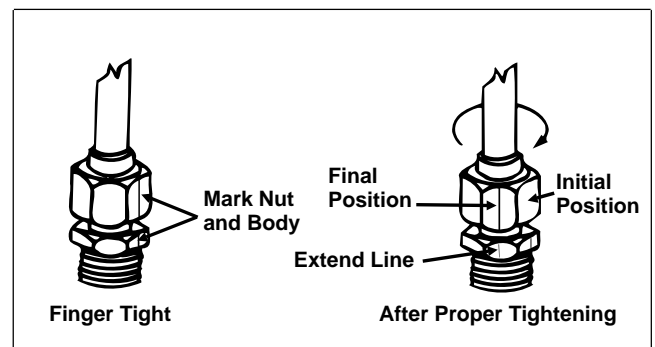

Figure 3

**SAE Straight Thread O-Ring Port - Non-adjustable (Fig. 4)**

1. Make sure both threads and sealing surfaces are free of burrs, nicks, scratches, or any foreign material.
2. Always replace the O-ring seal when this type of fitting shows signs of leakage.
3. Lubricate the O-ring with a light coating of oil.
4. Install the fitting into the port and tighten it down full length until finger tight.
5. Tighten the fitting to the correct flats from finger tight (F.F.F.T.).

Size	F.F.F.T.
4 (1/4 in. nominal hose or tubing)	1.00 ± .25
6 (3/8 in.)	1.50 ± .25
8 (1/2 in.)	1.50 ± .25
10 (5/8 in.)	1.50 ± .25
12 (3/4 in.)	1.50 ± .25
16 (1 in.)	1.50 ± .25

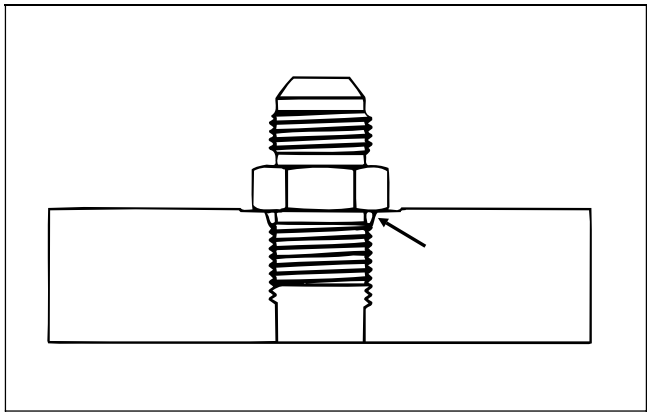

Figure 4

**SAE Straight Thread O-Ring Port - Adjustable (Fig. 5, 6)**

1. Make sure both threads and sealing surfaces are free of burrs, nicks, scratches, or any foreign material.
2. Always replace the O-ring seal when this type of fitting shows signs of leakage.
3. Lubricate the O-ring with a light coating of oil.
4. Turn back the jam nut as far as possible. Make sure the back up washer is not loose and is pushed up as far as possible (Step 1).
5. Install the fitting into the port and tighten finger tight until the washer contacts the face of the port (Step 2).
6. To put the fitting in the desired position, unscrew it by the required amount, but no more than one full turn (Step 3).
7. Hold the fitting in the desired position with a wrench and turn the jam nut with another wrench to the correct flats from finger tight (F.F.F.T.) (Step 4)

Size	F.F.F.T.
4 (1/4 in. nominal hose or tubing)	1.00 ± .25
6 (3/8 in.)	1.50 ± .25
8 (1/2 in.)	1.50 ± .25
10 (5/8 in.)	1.50 ± .25
12 (3/4 in.)	1.50 ± .25
16 (1 in.)	1.50 ± .25

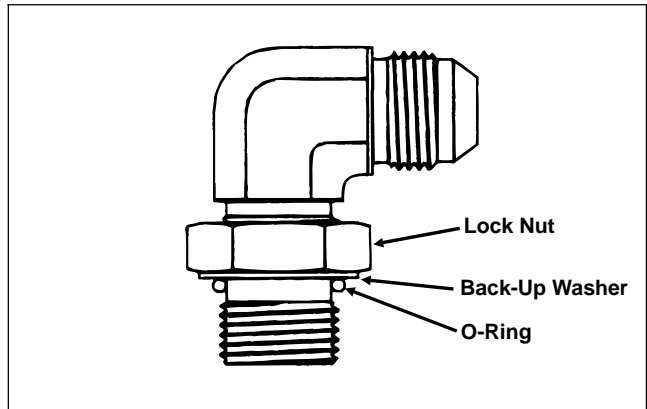

Figure 5

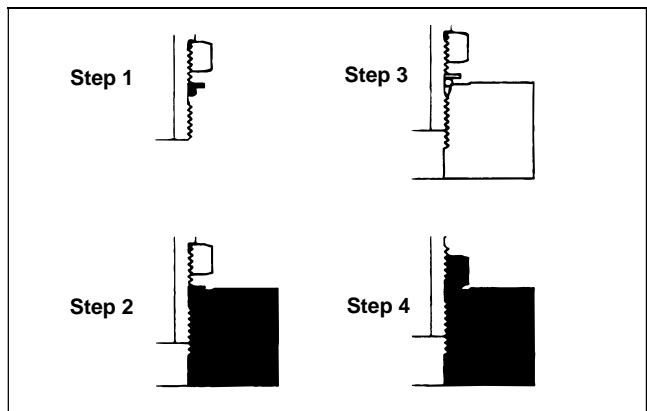

Figure 6

---

## Pushing or Towing (Fig. 7)

The machine can be pushed or towed for very short distances with the engine off, if necessary.

**IMPORTANT: Do not push or tow the machine faster than 5 MPH because the hydraulic pump may be damaged. If the machine must be moved further than a few feet, transport it on a trailer or pull with traction wheel raised and secured to a dolly. Whenever the machine is pushed or towed, the by-pass valve must be open. Hook on front of handle is used for a tie-down only, not a hitch point.**

1. Stop the engine and raise the hood.
2. Open the by-pass valve by turning it counterclockwise (2 turns maximum).
3. After moving the machine, close the by-pass valve by turning it clockwise. Tighten the by-pass valve to a torque of 7 to 10 ft-lb.

**IMPORTANT: Operating the machine with the by-pass valve open will cause improper operation and overheating of the hydraulic system.**

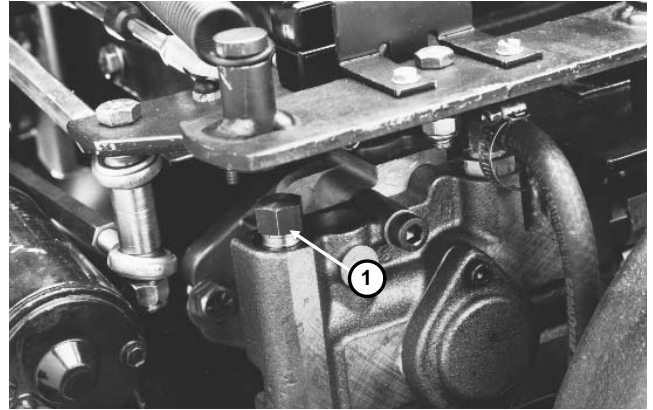

Figure 7

1. By-pass valve

# Hydraulic Diagram

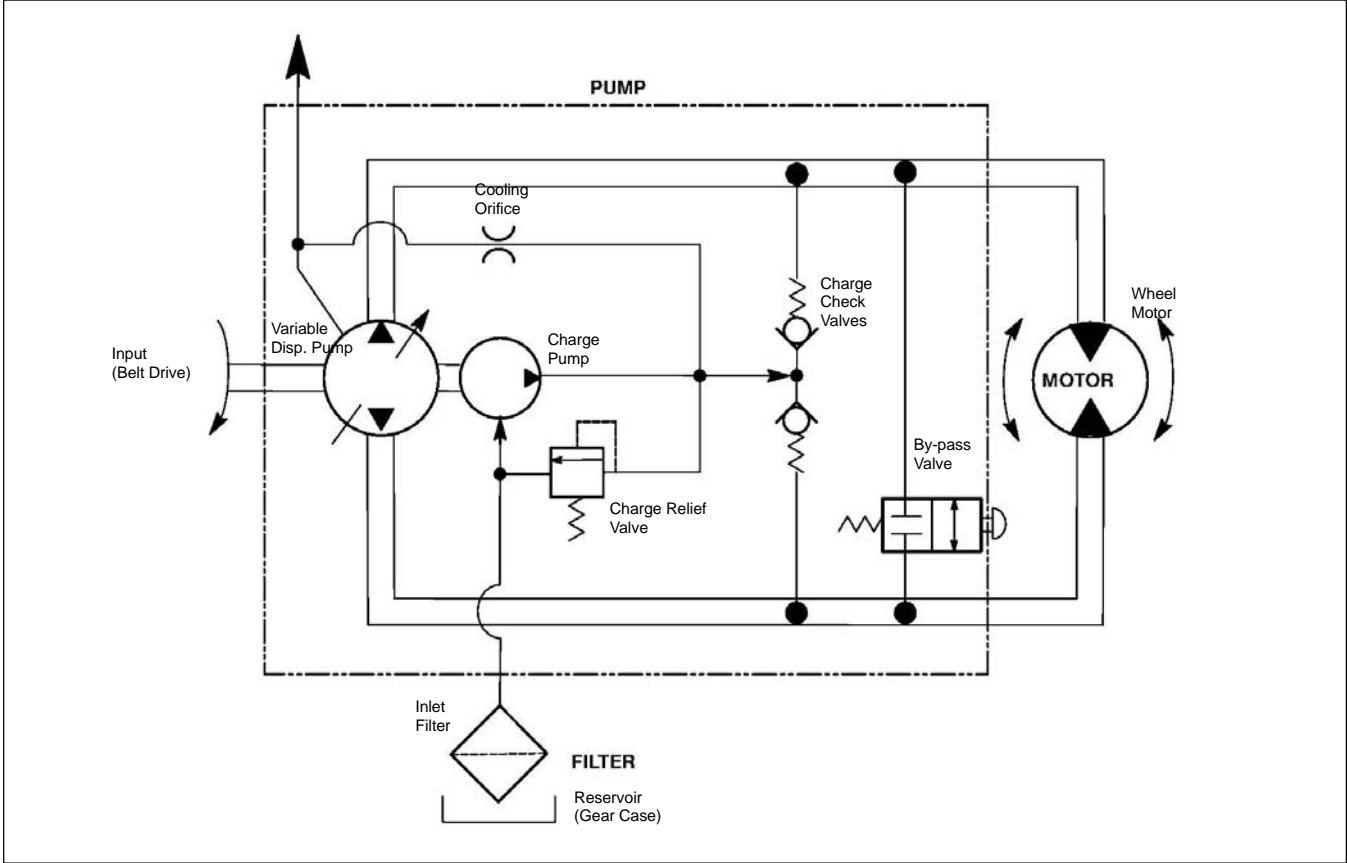

Figure 8

# Special Tools

NOTE: Order special tools from the *TORO SPECIAL TOOLS AND APPLICATIONS GUIDE (COMMERCIAL PRODUCTS)*. Some tools may be listed in the Hydroject 3010 Parts Catalog. Some tools may also be available from a local supplier.

## Hydraulic Tester - With Pressure and Flow Capabilities (Fig. 9)

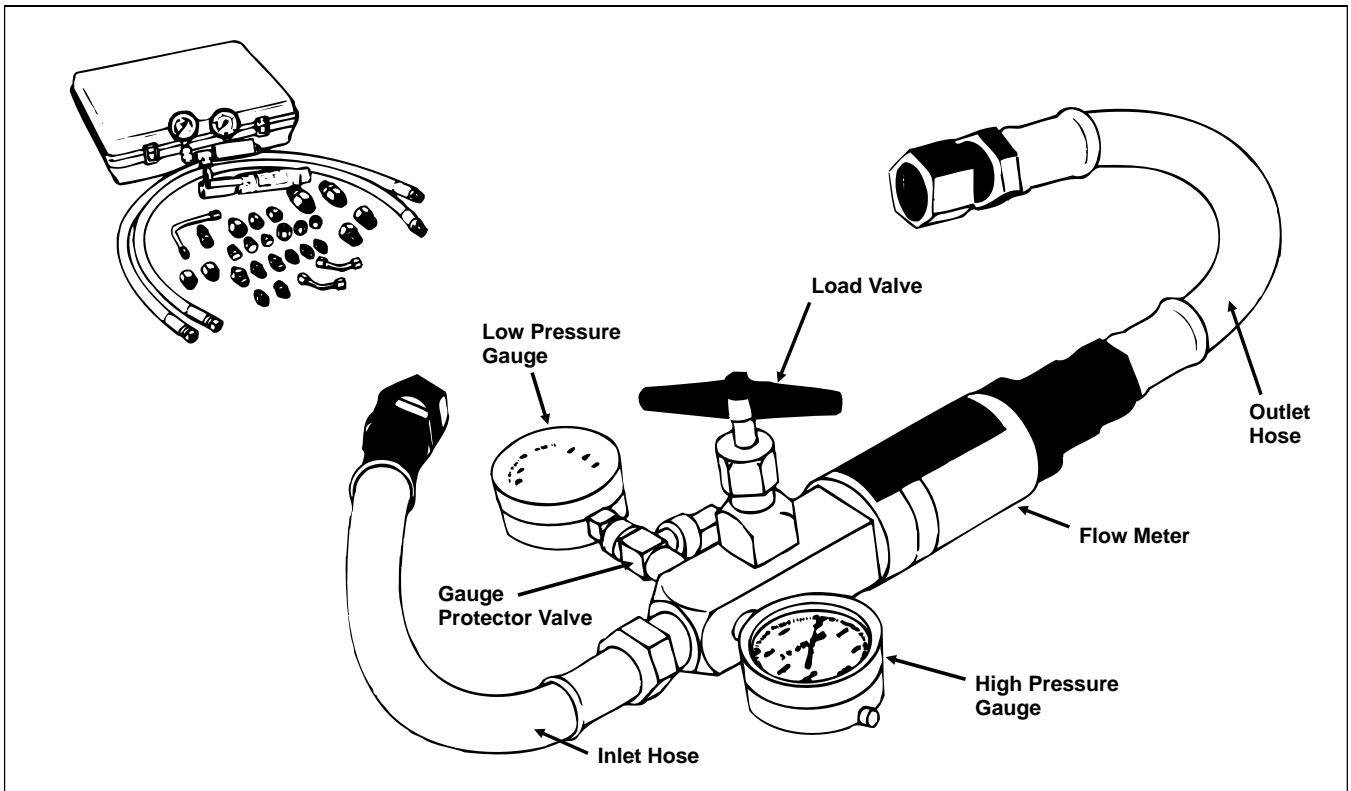

Figure 9

You must have o-ring face seal (ORFS) adapter fittings for this tester to use it on the HydroJect 3010.

1. **INLET HOSE:** Hose connected from the system circuit to the inlet side of the hydraulic tester.
2. **LOAD VALVE:** If required, upon turning the valve to restrict flow, a simulated working load is created in the circuit.
3. **LOW PRESSURE GAUGE:** Low range gauge to provide accurate reading at low pressure, 0 - 1000 psi.

This gauge has a protector valve which cuts out when pressure is about to exceed the normal range for the gauge. The cutout pressure is adjustable.

4. **HIGH PRESSURE GAUGE:** High range gauge to accommodate pressure beyond the capacity of the low pressure gauge, 0 - 5000.
5. **FLOW METER:** This meter measures actual oil flow in the operation circuit, with a gauge rated at 15 GPM.
6. **OUTLET HOSE:** Hose from the outlet side of the hydraulic tester to be connected to the hydraulic system circuit.

# Troubleshooting

The cause of an improperly functioning hydraulic system is best diagnosed with the use of proper testing equipment and a thorough understanding of the complete hydraulic system.

A hydraulic system with an excessive increase in heat or noise is a potential failure. Should either of these conditions be noticed, immediately stop the machine, turn off the engine, locate the cause of the trouble, and correct it before allowing the machine to be used again. Continued use of an improperly functioning hydraulic

system could lead to extensive internal component damage.

The charts that follow contain detailed information to assist in troubleshooting. There may possibly be more than one cause for a machine malfunction. All causes should be checked in the order in which they are listed on the charts.

Refer to the Testing section of this Chapter for precautions and specific test procedures.

## Transmission Operates in One Direction Only

Cause	Correction
Faulty traction control linkage.	Repair linkage
Transmission charge check valve defective.	Inspect and clean or replace charge/check.

## System Operates Hot, Loses Power or Will Not Operate in Either Direction

Cause	Correction
Faulty control linkage.	Repair linkage
Parking brake engaged.	Disengage parking brake.
Hydraulic oil level too low.	Fill to proper level.
By-pass valve open.	Close by-pass valve.
Clogged hydraulic filter.	Replace filter.
Low charge pressure - Test A.	Inspect charge relief valve and replace if faulty. Inspect charge pump and replace if faulty.
Low traction pump flow/pressure - Test B.	Repair or replace pump.
Low traction motor efficiency - Test C.	Repair or replace traction motor.

# Testing

The most effective method for isolating problems in the hydraulic system is by using hydraulic test equipment such as pressure gauges and flow meters in the circuits during various operational checks. (See the Special Tools section in this Chapter.)



## CAUTION

**Failure to use gauges with the recommended pressure (psi) rating as listed in the test procedures could result in damage to the gauge and possible personal injury from leaking hot oil.**

### Before Performing Hydraulic Tests

All obvious areas such as oil supply, filter, binding linkage, loose fasteners, or improper adjustments must be checked before assuming that a hydraulic component is the source of the problem being experienced.



## WARNING

**Before disconnecting or performing any work on the hydraulic system, all pressure in the system must be relieved by stopping the engine and opening the bypass valve.**

**Keep body and hands away from pin hole leaks or nozzles that eject hydraulic fluid under high pressure. Use paper or cardboard, not hands, to search for leaks. Hydraulic fluid escaping under pressure can have sufficient force to penetrate skin and do serious damage. If fluid is injected into the skin, it must be surgically removed within a few hours by a doctor familiar with this type of injury or gangrene may result.**

1. Thoroughly clean the machine before disconnecting or disassembling any hydraulic components. Always keep in mind the need for cleanliness when working on hydraulic equipment.

2. Put caps or plugs on any hydraulic lines left open or exposed during testing or removal of components.

3. The engine must be in good operating condition. Use a tachometer when making a hydraulic test. Engine speed can affect the accuracy of the tester readings.

4. To prevent damage to tester or components, the inlet and the outlet hoses must be properly connected, and not reversed (tester with pressure and flow capabilities).

5. To minimize the possibility of damaging components, completely open the load valve by turning it counter-clockwise (tester with pressure and flow capabilities).

6. Install fittings finger tight, far enough to insure that they are not cross-threaded, before tightening with a wrench.

7. Position the tester hoses so that rotating machine parts will not make contact with them and result in hose or tester damage.

8. Check the oil level in the reservoir.

9. Check the control linkage for improper adjustment, binding or broken parts.

10. All hydraulic tests should be made with the hydraulic oil at normal operating temperature.

## Hydraulic Tests (Fig. 10, 11)

1. Make sure hydraulic oil is at normal operating temperature by operating the machine for approximately 10 minutes.

2. Engage parking brake and stop the engine. Make sure parking brake is properly adjusted before performing hydraulic tests.

3. With engine off, disconnect hose from bulkhead fitting and install tester in series between traction pump and wheel motor. Make sure tester flow control valve is OPEN.

**IMPORTANT: Make sure that the oil flow indicator arrow on the flow gauge is showing that oil will flow from pump, through tester and to wheel motor.**

### Test A: Charge Pressure

4. Start the engine and move throttle to full engine RPM (approx. 3500 RPM).

GAUGE READING: 25 to 70 PSI no load.

5. If there is no pressure, or pressure is low, inspect for restriction in pump intake line and inlet filter. Inspect charge relief valve and valve seat. Inspect for sheared charge pump key. Disassemble charge pump and inspect for internal damage or worn parts. If charge pump is in good condition (no scoring, scratches, or excessive wear), piston pump and motor might be suspected of wear and inefficiency, thus charge pump is unable to keep up with internal leakage.

### TEST B: Traction Pump Flow

6. Lift the drive wheel off the ground using a jack. Block front and rear of the other wheels. Make sure the tester flow control valve is OPEN.

7. Start the engine and release the parking brake.

8. While watching flow and pressure gauges, move traction handle (up or down) so flow is from the pump, through the tester, then to the wheel motor. Move traction handle until 6 GPM is obtained.

9. If pressure is less than 200 to 300 PSI go to step 10. If pressure is more than 200 to 300 PSI stop the engine and inspect for binding parking brake. Inspect for restriction in lines to and from motor. If there are no restrictions, motor should be suspected of having internal damage.

10. While watching flow and pressure gauges, move traction handle (up or down) to full speed position so flow is from the pump, through the tester, then to the wheel motor. Slowly close flow control valve until you get readings of 7 GPM and 500 PSI.

NOTE: At pressures above approximately 500 PSI, mechanical override in handle will cause pump to begin to de-stroke.

11. If you cannot get 7 GPM or 500 PSI, traction pump may have internal damage or excessive wear.

### TEST C: Traction Motor Efficiency

12. Lower drive wheel to ground and engage parking brake. Block front and rear of all wheels. Chain machine to an immovable object and remove slack from chain.

13. With tester flow control valve open, slowly move traction handle (up or down) so flow is from the pump, through the tester, then to the wheel motor. Move traction handle until maximum pressure is attained with wheel not rotating and read flow gauge.

14. If flow reading is higher than 1.5 GPM, motor may have internal damage or excessive wear.

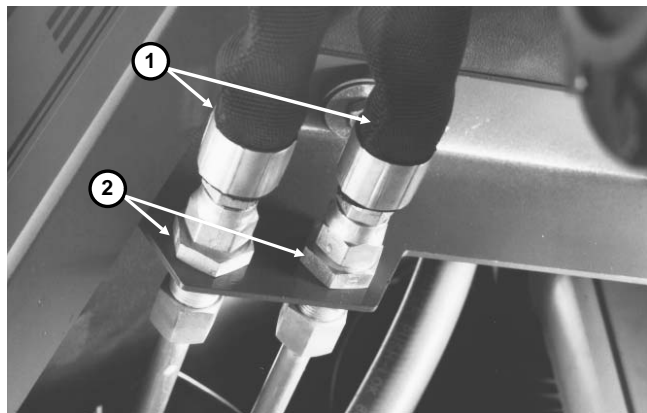

Figure 10

1. Hose

2. Bulkhead fitting

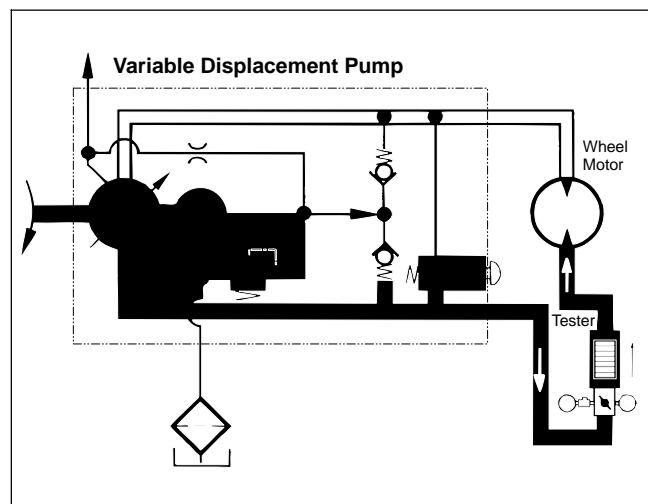

Figure 11

# Adjustments

## Traction Cable Adjustment (Fig. 12)

1. Park machine on a level surface, stop the engine and open the hood. Remove lower cover from handle.
2. Adjust pump end of push-pull cable with pump lever in neutral starting position by adjusting jam nuts so distance from seal to threads is  $1.00 \pm 0.05$  in.
3. Adjust jam nuts at tiller end of push-pull cable so traction handle is centered on control handle.

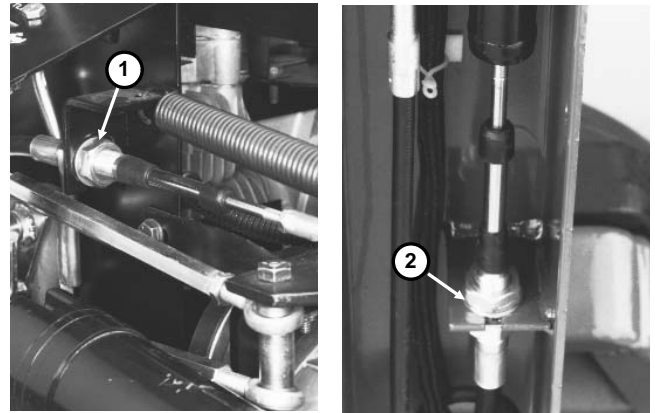

Figure 12

1. Jam nuts - pump end      2. Jam nuts - tiller end

## Speed Control Adjustment (Fig. 13)

1. Park machine on a level surface, stop the engine and open the hood.
2. Adjust speed control cable (Item 26) so speed stop lever (Item 9) can move to horizontal position.
3. Adjust speed rods (Item 14) so rod end mounting holes in pivot arms (Items 11, 23) are located vertically in line with pivot pin (Item 22).

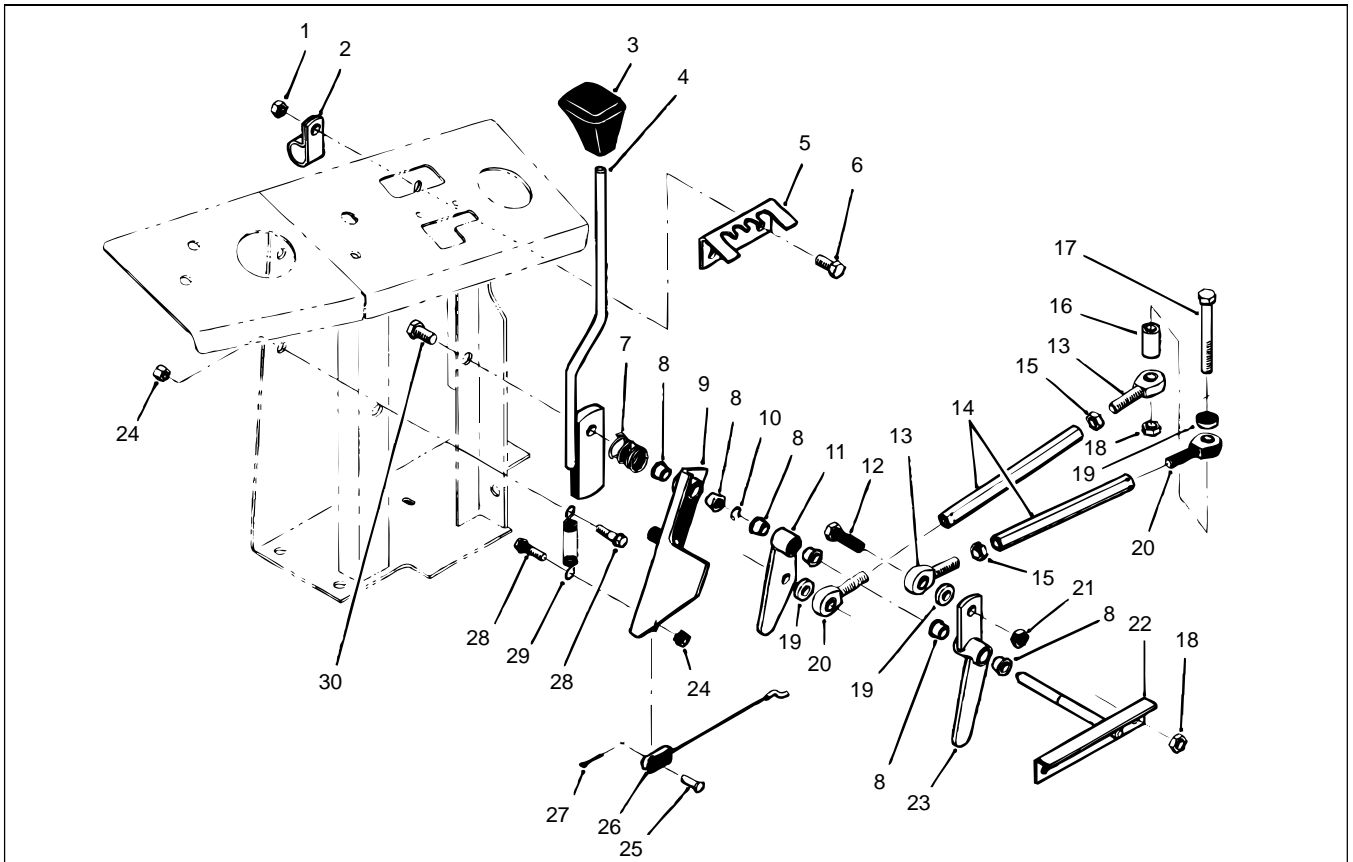

Figure 13

---

## Transmission Neutral Adjustment (Fig. 14)

If machine moves when lever is released, transmission neutral adjustment is needed.

1. Park machine on a level surface, stop the engine and open the hood.
2. Lift drive wheel off the ground using a jack. Block front and rear of other wheels.
3. Start engine and release parking brake.
4. Slightly loosen locknut on top of neutral adjustment cam and rotate cam hex until traction wheel stops rotating. Tighten the locknut.
5. Move traction bail completely up and down. Release handle and check for wheel rotation. If wheel continues rotating, repeat step 4.
6. If problem continues, stop the engine, check linkage for binding or damage, then do adjustment procedure again.
7. Loosen two (2) screws and adjust switch tab so switches are actuated when pump control is in neutral and not actuated when pump control is stroked.

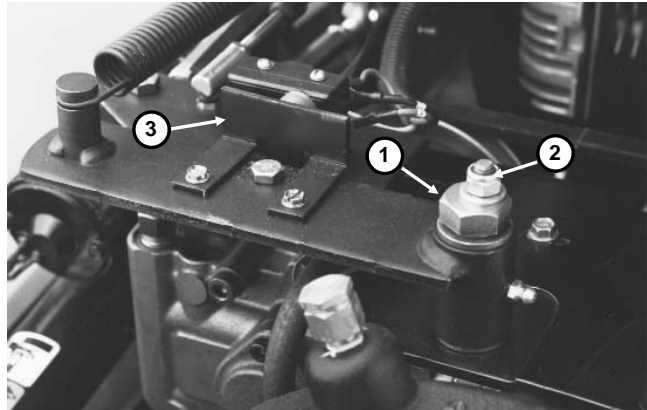

Figure 14

1. Neutral adjustment cam
2. Locknut
3. Switch tab

---

## Aeration Speed Adjustment (Fig. 15)

1. Park machine on a level surface, stop the engine and open the hood.
2. Put speed control lever into second slot from left (while facing control panel).
3. Lower machine into aerate mode so transport wheels are off the ground.
4. Lift drive wheel off ground using a jack.
5. Start the engine and release the parking brake.
6. Operate engine at full speed.
7. Move traction handle UP to full speed position.
8. Loosen jam nuts and adjust LOWER speed rod until traction wheel rotates at 20-22 RPM. Tighten jam nuts.
9. Move traction handle DOWN to full speed position.
10. Adjust UPPER speed rod until traction wheel rotates at 20-22 RPM. Tighten jam nuts.

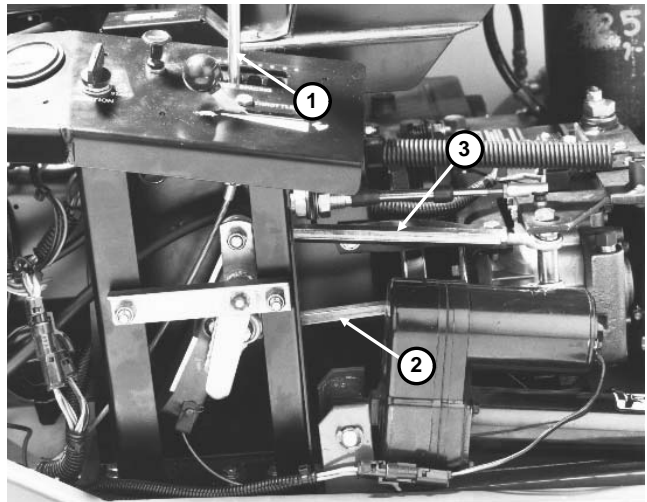

Figure 15

1. Speed control lever
2. Lower speed rod
3. Upper speed rod

## Traction Pump Belt Adjustment (Fig. 16, 17)

1. Park machine on a level surface, stop the engine and open the hood.

2. Check belt tension by depressing belt midway between pulleys with 3 lb. of force. Belt should deflect 1/4 in.

3. If adjustment is necessary:

A. Loosen pivot nut securing pump mount to pump support.

B. Loosen adjusting nut securing pump and pump mount to slotted pump support.

C. Loose three (3) capscrews securing pulley guard bracket (Fig. 20, Item 21) to control panel and pump support.

D. Use a pry bar in hole on pump bracket to pull pump towards outside of machine until you get proper belt tension, then tighten adjusting nut to secure pump and pump mount to pump support.

E. Tighten pivot nut. Tighten three (3) capscrews securing pulley guard bracket.

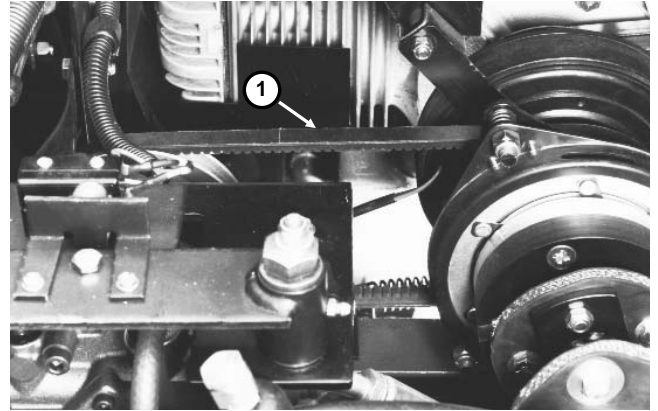

Figure 16

1. Traction pump belt

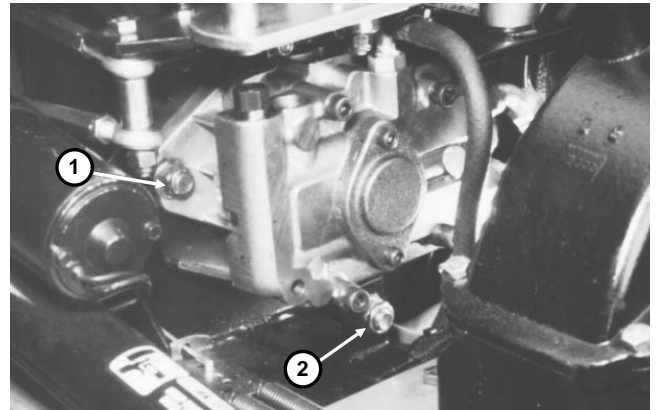

Figure 17

1. Adjusting nut  
2. Pivot nut

# Repairs

## Traction Pump Belt Replacement (Fig. 18, 19)

1. Park machine on a level surface, engage parking brake, open hood and disconnect engine spark plug wires.
2. Remove pulley guard bracket (Fig. 20, Item 21).
3. Remove drive coupling (see Drive Coupling Removal and Installation in Chapter 6 - Water System).
4. Disconnect valve clutch electrical connector.
5. Remove valve clutch stops.
6. Loosen pivot nut securing pump mount to pump support.
7. Loosen adjusting nut securing pump and pump mount to slotted pump support.
8. Push pump towards inside of machine to loosen belt tension and remove the belt.
9. Reverse steps 2 - 8 to install new belt.
10. Adjust belt tension (see Traction Pump Belt Adjustment).

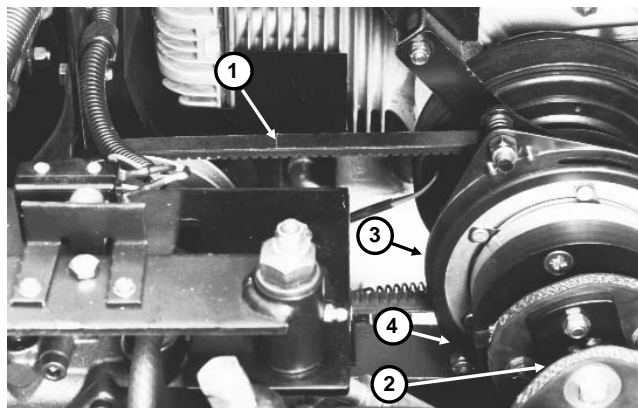

Figure 18

1. Pump drive belt
2. Drive coupling
3. Valve clutch
4. Valve clutch stops

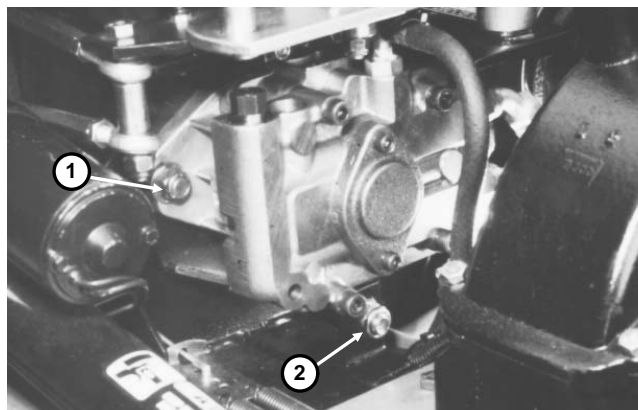

Figure 19

1. Adjusting nut
2. Pivot nut

## Hydraulic Pump Removal and Installation (Fig. 20)

1. Park machine on a level surface, engage parking brake, open hood and disconnect engine spark plug wires.
2. Disconnect wires from neutral and pump switches (Item 31) on hydraulic pump. Label wires for proper reinstallation.
3. Remove extension spring (Item 17).
4. Disconnect stroke control cable ball joint (Item 43) from pump lever (Item 30). Disconnect upper and lower speed adjustment rods from pump lever (see Fig. 14).
5. Loosen belt tension and remove belt from pump pulley (see Pump Belt Tension Adjustment).
6. Disconnect hydraulic lines from fittings on pump. Put caps on open lines and fittings to prevent contamination. Put labels on hydraulic lines for proper reinstallation.
7. Remove locknut (Item 46), capscrew (Item 5) and washers (Item 47). Remove locknut (Item 54) and cap-screw (Item 57).
8. Remove pump assembly from pump support (Item 55) and put pump on a work bench.
9. Loosen jam nuts (Item 3) and set screws (Item 2). Remove pulley (Item 4) from pump shaft.
10. Remove pump mount (Item 6) from pump.
11. Loosen locknuts (Item 36) and remove roll pin (Item 34). Pull pump lever (Item 30) off of pump control shaft.
12. Remove hydraulic fittings from pump and plug ports.
13. Reverse steps 2 - 12 to install pump.

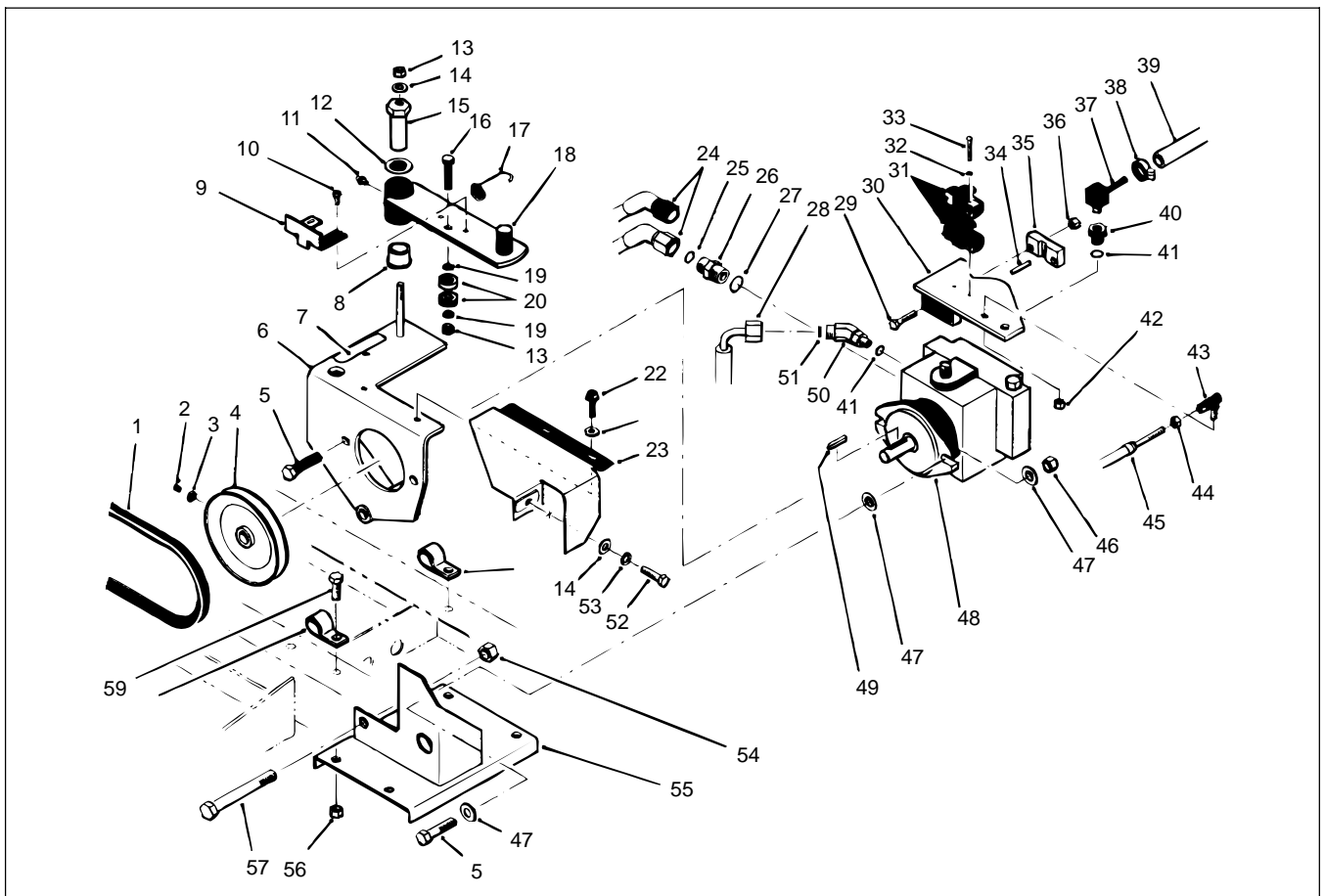

Figure 20

## Pump Shaft Seal Replacement (Fig. 21)

Lip type seals are used on input shaft and displacement control shaft. These seals can be replaced without major disassembly of pump.

1. Remove retaining ring from housing (input shaft seal only).

2. Carefully pull seal out of housing bore. A “hook” type tool may be used to grasp seal and pull it out, or a slide hammer type puller may be used to remove seal. Be careful not to damage housing bore, shaft sealing surface, or bearing. After the seal is removed, it cannot be used again.

**IMPORTANT: When input shaft seal is removed, pump block spring may push shaft partially out of housing. Do not attempt to pull shaft out of housing. Internal parts could move out of alignment or fall into pump, requiring major disassembly of pump.**

3. Inspect sealing area of shaft for rust, wear or contamination. Polish sealing area on shaft if necessary.

4. Lubricate new seal with petroleum jelly.

5. Wrap shaft with thin plastic or use a seal protector to prevent damage to seal lip during installation.

6. Slide seal over shaft and press it into housing bore. Be careful not to damage the seal.

7. Install seal retaining ring into housing (input shaft seal only).

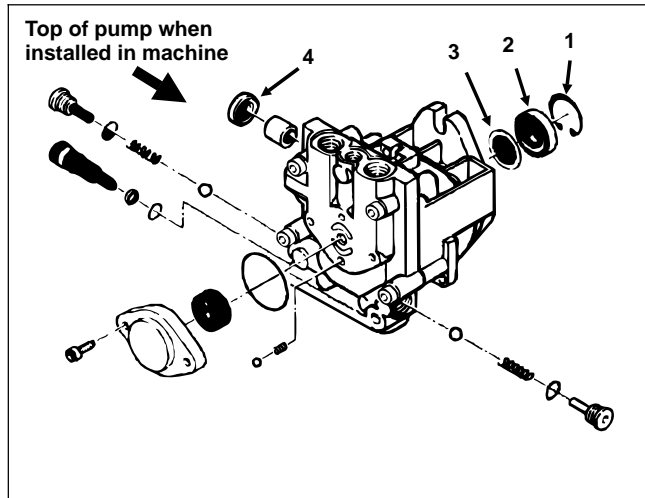

Figure 21

1. Retaining ring
2. Seal (input shaft)
3. Spacer
4. Seal (displacement control shaft)

## Pump Charge Check Valve Service (Fig. 22)

1. Remove check valve plug with a 1/4 in. internal hex wrench.

2. Remove valve spring and check ball from pump end cap.

**IMPORTANT: Do not allow check balls to fall into closed loop passages in end cap.**

3. Inspect check balls and mating seats in end cap for damage or foreign material.

4. Lay pump on its side and reinstall check ball, spring and plug (with O-ring) into end cap. Make sure check ball does not fall into closed loop passage inside pump. Tighten plug to a torque of 15 to 35 ft-lb. Turn pump over and repeat installation procedure for other check valve.

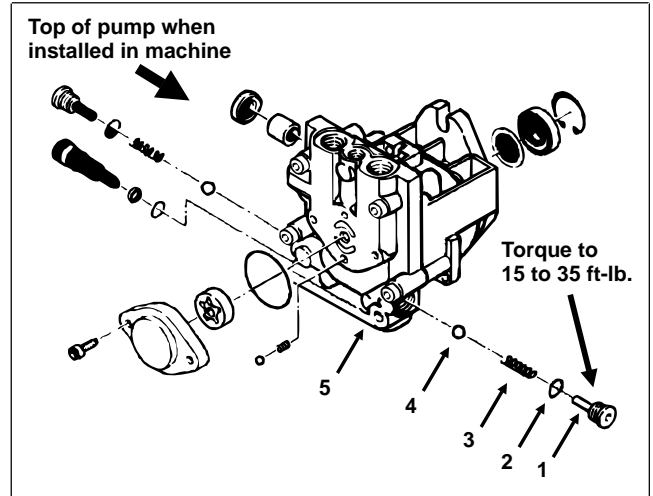

Figure 22

1. Check valve plug
2. O-ring
3. Check valve spring
4. Check ball
5. Pump end cap

## Pump Bypass Valve Service (Fig. 23)

1. Unscrew bypass valve from end cap of pump.

2. Inspect valve and mating seat in end cap for damage and foreign material. It is recommended that the O-ring and back-up ring be replaced.

3. Reinstall bypass valve into end cap. Tighten to a torque of 7 to 10 ft-lb.

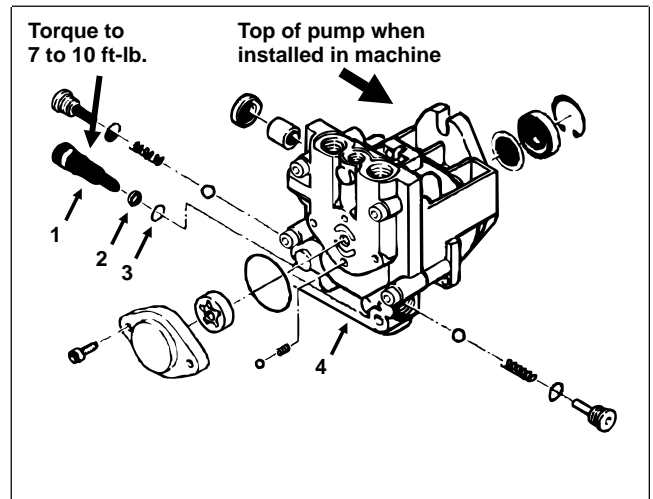

Figure 23

1. Bypass valve
2. Back-up ring
3. O-ring
4. Pump end cap

---

## Charge Pump Service (Fig. 24)

1. Use a 5 mm internal hex wrench to remove the two (2) screws holding charge pump cover to pump end cap.

NOTE: Charge pump rotation is determined by orientation of charge pump cover on pump end cap. Cast boss on charge pump cover indicates orientation. Note orientation of cast boss before removing charge pump cover.

2. Remove charge pump cover and O-ring.

3. Remove charge pump gerotor assembly.

4. Remove charge relief valve spring and ball.

5. Inspect gerotor assembly, charge pump cover and end cap for abnormal wear, damage or foreign material. Inspect charge relief valve seat in end cap for damage or foreign material.

6. Before installing charge pump, apply a small amount of petroleum jelly to inside diameter, outside diameter and slide faces of gerotor assembly.

7. Install charge relief ball and spring.

8. Install charge pump gerotor assembly.

9. Install charge pump cover and O-ring. Make sure charge relief spring enters recess in cover.

10. Install charge pump cover screws and tighten to a torque of 84 to 120 in-lb.

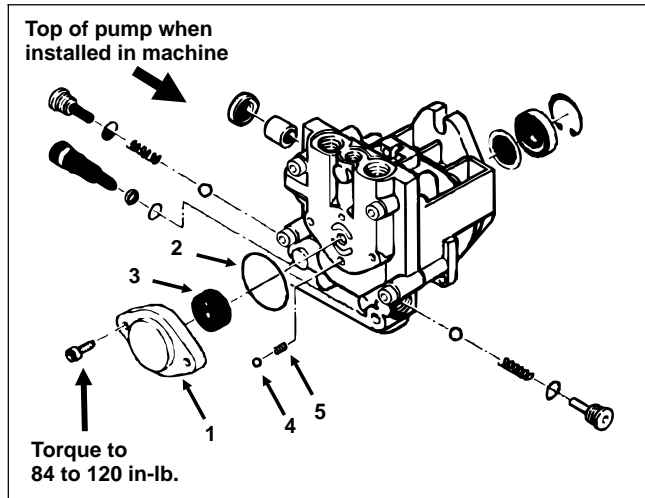

Figure 24

1. Charge pump cover
2. O-ring
3. Gerotor assembly
4. Charge relief ball
5. Charge relief spring

---

## Major Pump Repair (Fig. 25, 26)

The procedures on the following pages are for complete disassembly and reassembly of the pump.

Cleanliness is a primary means of assuring satisfactory transmission life, on either new or repair units. Cleaning parts by using a clean solvent wash and air drying is usually adequate. As with any precision equipment, all parts must be kept free of foreign materials and chemicals. Protect all sealing surfaces and open cavities from damage and foreign material.

During assembly of the pump, all surfaces which have relative motion between two parts should be coated with a film of clean hydraulic oil. This will assure that these surfaces will be lubricated during start-up.

It is recommended that all gaskets, o-rings and seals be replaced. Lightly lubricate all o-rings with clean petroleum jelly before assembly. All gasket sealing surfaces must be cleaned before installing new gaskets.

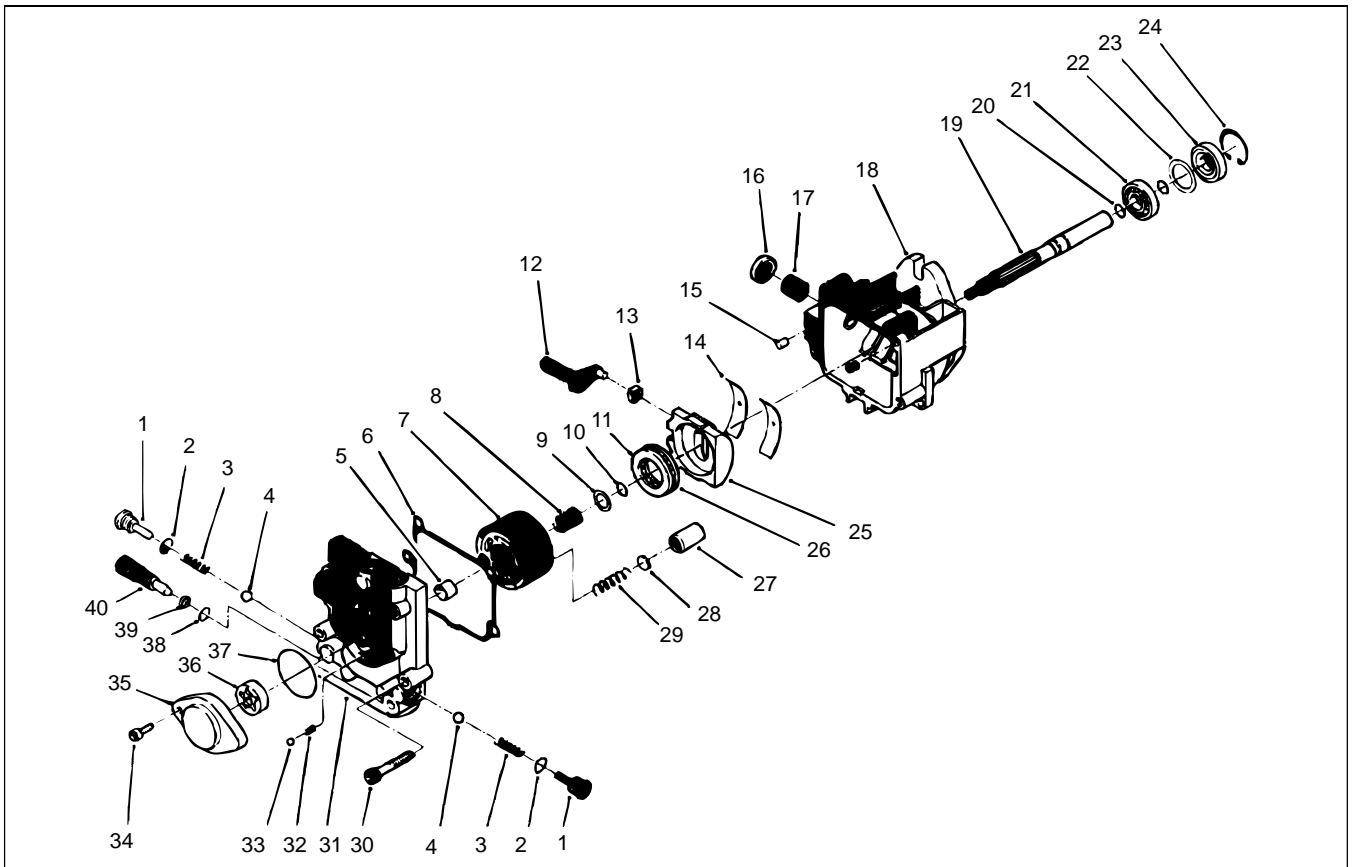

Figure 25

### Disassembly of Hydraulic Pump

1. Before performing major repairs on the pump, remove external components as described in previous procedures. These include the following:

- Shaft Seals
- Charge Check Valves
- Bypass Valve
- Charge Pump

2. Lay pump on its side. Use a 6 mm internal hex wrench to remove the four (4) screws (Item 30) which retain end cap to variable pump housing.

3. Internal springs will separate end cap from housing. Remove end cap (Item 31) from housing (Item 18).

**IMPORTANT: Pump cylinder block (Item 7) will stick to surface of end cap. Be careful to prevent damage to end cap and cylinder block.**

4. Remove gasket (Item 6) and two (2) alignment pins (Item 15) from housing.

5. Remove cylinder block kit (Item 7) from shaft (Item 19).

6. Remove cylinder block spring (Item 8) and washer (Item 9) from shaft.

7. Remove swashplate assembly (Item 25) from housing.

8. Remove thrust plate (Item 11) from swashplate. The bearing guide is pressed into the swashplate and is usually not removed. The inner thrust washer is retained by the bearing guide.

9. Remove slot guide block (Item 13) from displacement control shaft (Item 12).

10. Remove swashplate cradle bearings (Item 14) from housing.

11. Remove input shaft seal retaining ring (Item 24).

12. Carefully pull input shaft seal (Item 23) out of housing bore. A hook may be used to pry seal out, or a slide hammer type puller may be used to remove the seal. Be careful not to damage housing bore, shaft sealing surface, or bearing. After seal is removed it cannot be used again.

13. Remove bearing spacer washer (Item 22).

14. Remove pump shaft (Item 19) and bearing assembly from housing.

15. Remove outer bearing retaining ring (Item 21) (and washer, if used). Press shaft out of bearing.

16. If pump block retaining spring retaining ring (Item 10) requires replacement, remove it from pump shaft.

17. Remove displacement control shaft from housing.

18. Pry displacement control shaft seal out of housing. Care must be taken so as not to damage housing bore.

19. If displacement control shaft journal bearing requires replacement, press it out of housing.

### Inspection and Replacement of Pump Parts

After disassembly, thoroughly clean all parts in a suitable solvent. Replace all o-rings, gaskets and seals.

Inspect all parts for damage, nicks or unusual wear patterns. Replace all parts having unusual or excessive wear or discoloration.

Inspect seal surfaces, bearing surfaces and shaft splines. Polish sealing areas on shafts if necessary. Replace any worn or damaged parts.

The pump shaft bushing (Item 5) is pressed into end cap and is usually not removed.

The running surfaces of cylinder blocks MUST be flat and free from scratches. If scratches or wear are found on running surfaces of cylinder blocks or end cap, polish or replace the parts. When polishing these surfaces, up to 0.0004 in. may be removed. If this is not sufficient to obtain a flat surface, free of scratches, the part should be replaced.

### Assembly of Hydraulic Pump

1. Clean and lightly oil parts before assembly. Tighten all threaded parts to recommended torque value.

**IMPORTANT: Most parts have critical, high tolerance surfaces. Use caution to prevent damage to these surfaces during assembly. Protect exposed surfaces, openings and ports from damage and foreign material.**

2. If displacement control shaft bearing (Item 17) has been removed, press a new bearing into housing using a suitable press pin. Surface of bearing should be flush with inside surface of housing.

NOTE: The position of the bearing in the housing determines control shaft end play. Do not press bearing deeper into housing at this time.

3. Install displacement control shaft (Item 12) into housing.

4. If block spring retaining ring (Item 10) was removed from pump shaft, install a new retaining ring at this time.

5. Install inner bearing retaining ring (Item 20) onto shaft. Press bearing (Item 21) onto shaft, install washer (if used) and new outer bearing retaining ring. Be careful not to stretch or deform retaining rings.

**IMPORTANT: Be careful not to damage shaft sealing surface.**

6. Install pump shaft and bearing assembly into housing.

7. Install bearing spacer washer (Item 22).

8. Wrap shaft with thin plastic or use a seal protector to prevent damage to seal during installation. Lubricate new pump shaft seal (Item 23) with petroleum jelly.

9. Slide seal over shaft and press it into housing bore. Be careful not to damage the seal.

10. Install retaining ring (Item 24).

11. Install swashplate cradle bearings (Item 14) into housing, making sure they are located on cast-in pins in housing.

12. Install slot guide block (Item 13) onto displacement control shaft.

13. Install thrust plate (Item 11) into swashplate (Item 25). Slot on swashplate must engage guide block (Item 13) on displacement control shaft (Item 12). Use a tool such as a screwdriver or magnet to hold guide block in position while installing swashplate.

14. Hold swashplate in position and use a dial indicator or depth gauge to measure side play of displacement control shaft. Using a suitable sleeve, press control shaft bearing into housing until control shaft end play is between 0.020 and 0.060 in.

15. Install thrust washer (Item 9) and cylinder block spring (Item 8) onto pump shaft.

16. Install springs (Item 29), piston washers (Item 28) and pistons (Item 27) into cylinder block kits. The pistons must move freely in their bores.

17. With pump swashplate in "neutral" (0 angle) position and pump housing laying on its side, install pump cylinder block kit onto pump shaft in housing.

18. Check that piston springs are centered in cylinder block bores, If necessary, move springs into position with a small screwdriver.

**IMPORTANT: Do not damage running surfaces of cylinder blocks.**

19. Install two (2) alignment pins (Item 15) and install a new gasket (Item 6) onto housing.

20. Lubricate running surfaces of end cap (Item 31) and cylinder blocks (Item 7). Position housing opening UP and install end cap onto housing (Item 18).

**IMPORTANT: Make sure all parts are properly aligned. Do not force end cap into position on housing. Be careful to prevent damage to end cap and cylinder block sealing surfaces.**

21. When end cap is properly installed, the internal springs will hold it away from the housing approximately 3/8 in.

22. Install the four (4) capscrews which retain end cap to housing. Tighten screws to a torque of 138 to 180 in-lb.

23. Rotate shafts to assure correct assembly. When properly assembled, minimal torque should be required to turn shafts.

24. Wrap end of displacement control shaft with thin plastic or use a seal protector to prevent damage to seal during installation. Lubricate new displacement controls shaft seal (Item 16) with petroleum jelly. Slide seal over shaft and press it into housing bore. Be careful not to damage seal. Install seal flush to bottomed in bore.

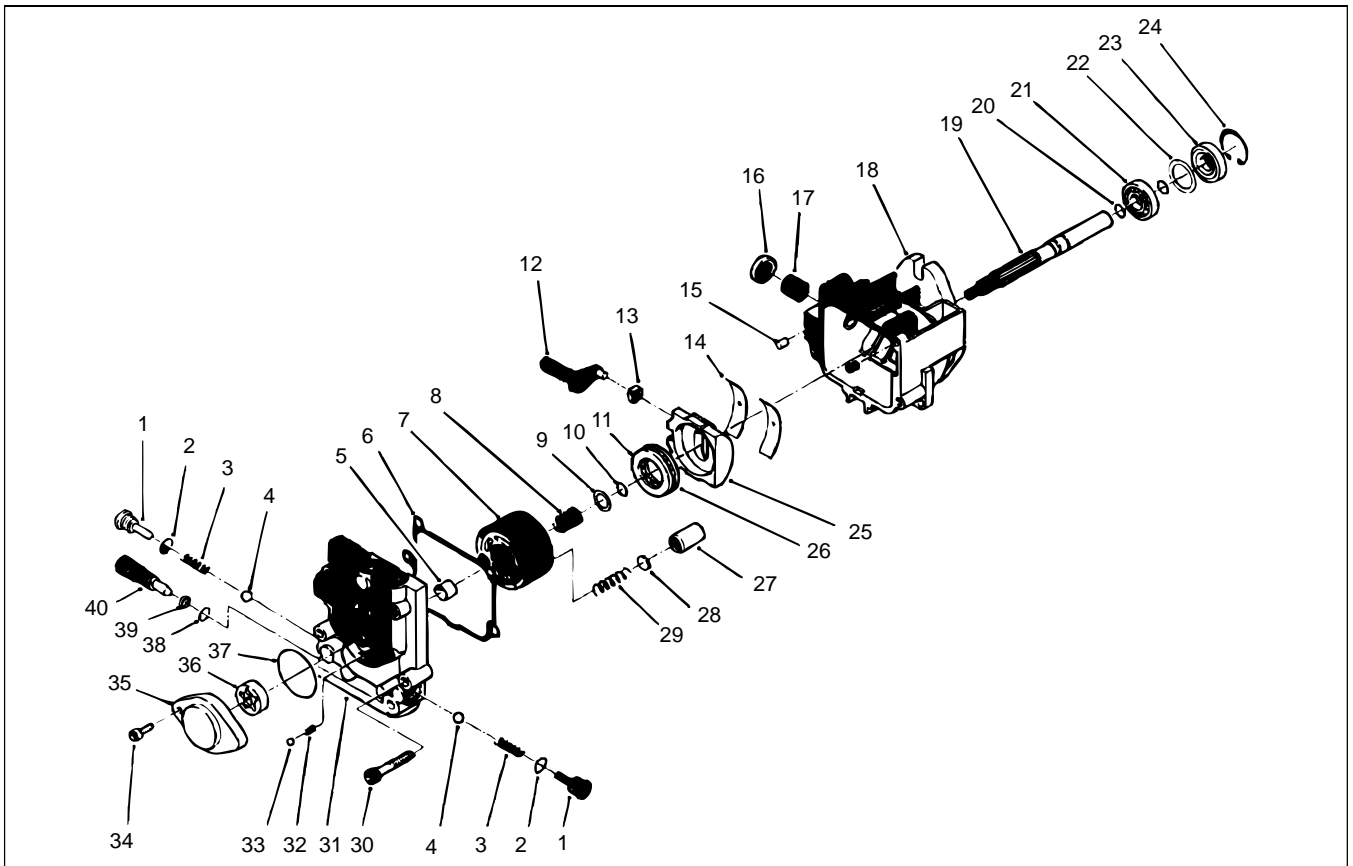

Figure 26

## Wheel Motor Removal and Installation (Fig. 27)

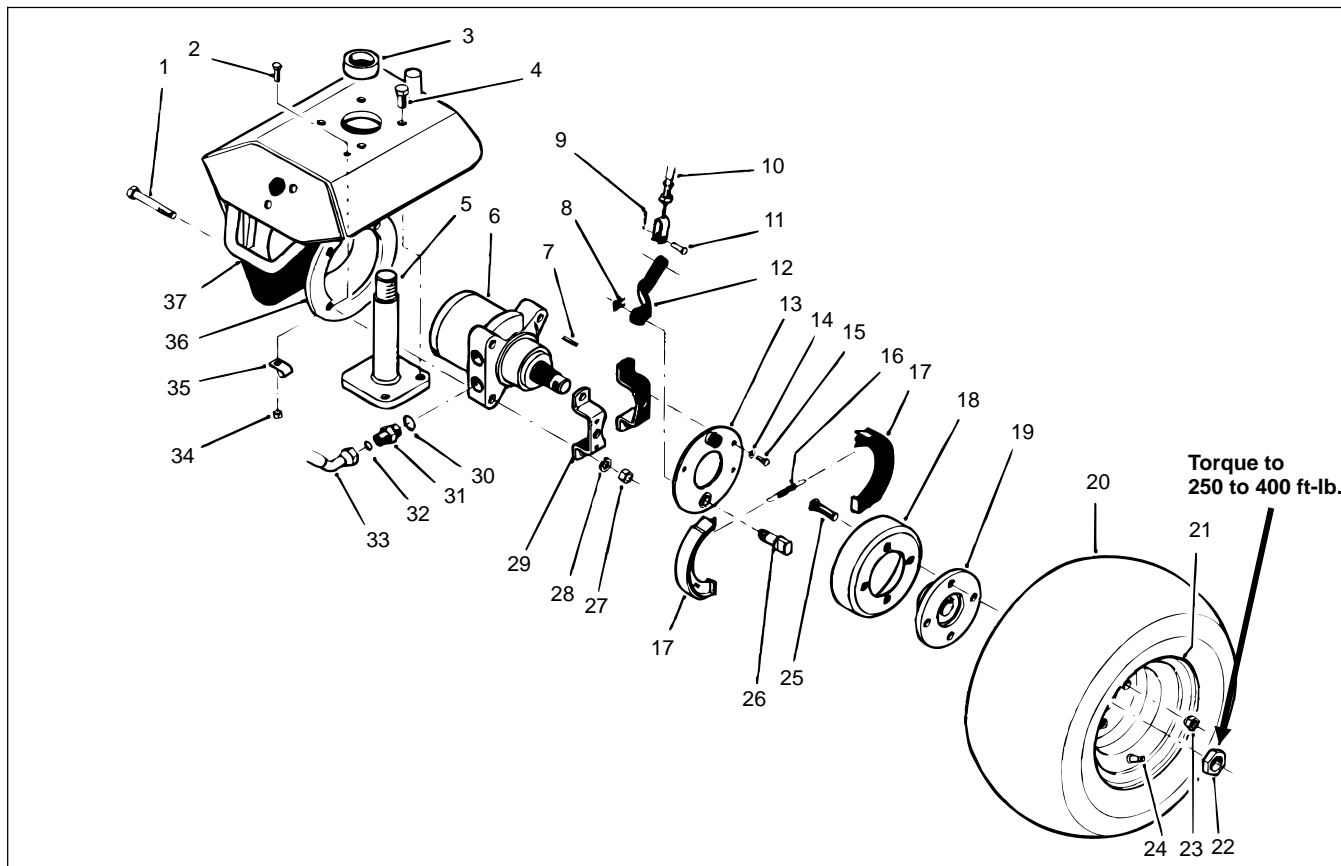

Figure 27

1. Park machine on a level surface, engage parking brake, open hood and disconnect engine spark plug wires. Lift drive wheel off the ground using a jack. Block front and rear of other wheels.

2. Remove wheel nuts (Item 23) and remove wheel. Remove large nut (Item 22) from wheel hub.

3. Mount a wheel puller to wheel mount studs and remove wheel hub (Item 19) and brake drum (Item 18). Remove key (Item 7) from wheel motor shaft.

**IMPORTANT: To prevent damage to wheel motor, DO NOT hit wheel hub with a hammer during removal or installation.**

4. Disconnect hydraulic lines from fittings on wheel motor. Put caps on open lines and fittings to prevent contamination. Put labels on hydraulic lines for proper reinstallation.

5. Remove four (4) cap screws (Item 1), nuts (Item 27) and lockwashers (Item 28) to remove wheel motor (Item 6) and brake brackets (Item 29) from steering arm (Item 37).

6. Reverse steps 1 - 6 to install wheel motor. When installing wheel hub onto motor shaft, tighten large nut (Item 22) to 250 - 400 ft-lb.

## Wheel Motor Shaft Seal and/or Shaft Replacement (Fig. 28)

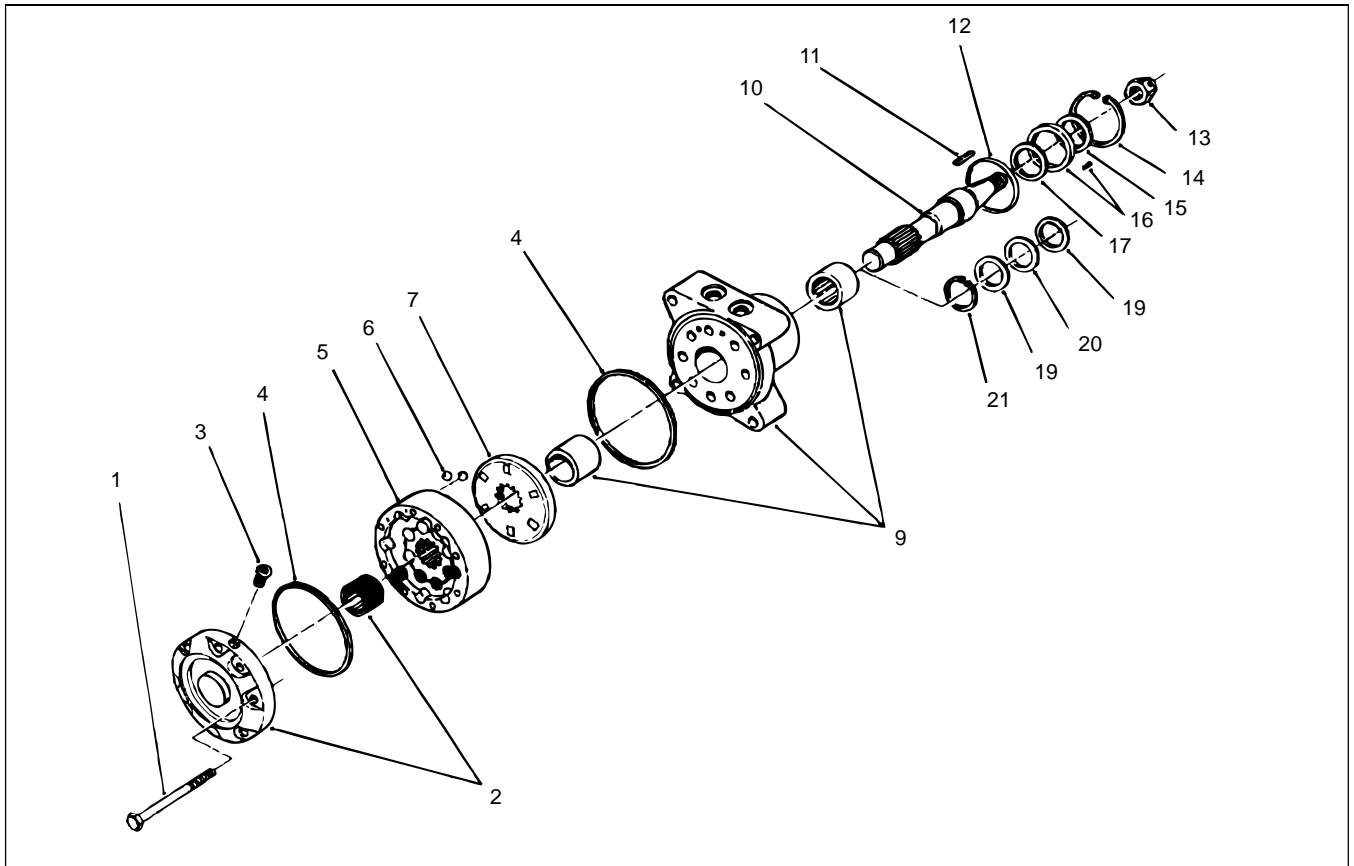

Figure 28

### Disassembly of Shaft and Front Seal Assembly

1. Put motor on a clean, flat surface with shaft facing up. Clean front end of motor to avoid contaminating internal parts during procedure.
2. Remove key (Item 11) from shaft.
3. Remove snap ring (Item 14) using a snap ring pliers.
4. Pull shaft (Item 10) out vertically.

**IMPORTANT: When pulling shaft vertically, do not rotate shaft or move motor as this may alter internal timing.**

5. With seal retainer assembly and shaft assembly removed, remove all parts from shaft and inspect various parts of seal assembly (Item 15, 16, 17), shaft (Item 10) and thrust bearing assembly (Item 19, 20, 21). Replace any worn or damaged parts. Always replace seal retainer assembly (Item 15, 16, 17). The shaft should have smooth polished surfaces in bearing and seal areas. If the shaft is lightly scratched in these areas, polish with fine emery paper in a circumferential direction. However, if the shaft has any pitting or deep

scratches, entire motor should be disassembled for inspection.

### Assembly of Shaft and Front Seal Assembly

1. Assemble thrust washers (Item 19) and thrust bearing (Item 20) on shaft using the snap ring (Item 21). Snap ring sharp edges **MUST** face away from thrust washers with thrust bearing (Item 20) between washers.
2. Slowly lower spline end of shaft (Item 10) assembly into motor body using caution not to rotate internal parts once shaft spline starts to engage.
3. Put lightly oiled o-ring (Item 12) into groove in body bore.
4. Gently slide oiled seal retainer assembly (Item 15, 16, 17) over shaft, chamfered side first, and press into body bore. When fully in place, body snap ring groove will be visible.
5. Install snap ring (Item 14) into its body groove with snap ring's sharp edges facing outward and retainer pin between snap ring lugs. Be sure snap ring is completely seated in groove.

## Wheel Motor Repair (Fig. 29)

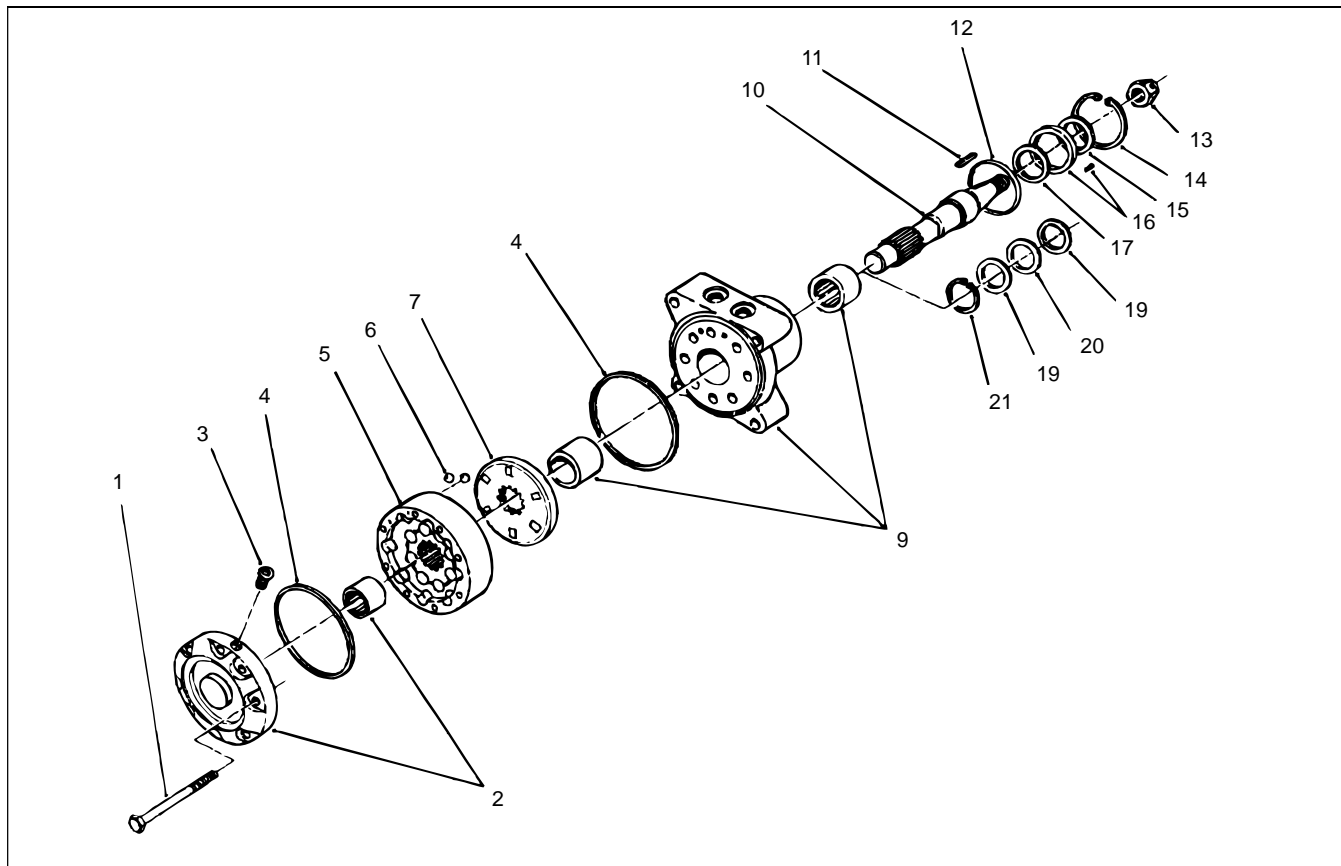

Figure 29

**IMPORTANT:** Before **DISASSEMBLING** motor, plug open ports and clean all dirt from outside of motor.

**IMPORTANT:** Before **ASSEMBLING** motor, lightly oil all seals, rollers and threaded bolt ends.

### Disassembly of Cover Section of Motor

1. Remove key (Item 11) from shaft.
2. Mount motor in a vice or other holding device with shaft facing down.
3. Remove the eight capscrews (Item 1).
4. Remove cover & bearing assembly (Item 2) and square ring seal (Item 4).
5. Remove IGR assembly (Item 5) starting with outer locating ring, rollers, outer rolls, inner rotor and valve plate (Item 7). If any of these components are damaged, entire IGR assembly must be replaced.
6. Remove the two check balls (Item 6).

**NOTE:** The check balls may fall into body tapered holes or into body valve ports during disassembly. Be sure that the check balls are removed.

### Disassembly of Shaft Section of Motor

(See Disassembly of Shaft and Front Seal Assembly under Main Shaft Seal and/or Shaft Replacement.)

### Assembly of Complete Motor

1. Before assembly, all parts must be cleaned with a suitable solvent and free of nicks and burrs.
2. Mount body with pilot and bearing facing up in a vise or other holding mechanism.
3. Insert shaft (Item 10) and install seals and thrust bearings. (See Assembly of Shaft and Front Seal Assembly under Main Shaft Seal and/or Shaft Replacement.)
4. Mount body with pilot and bearing facing down in a vise or other holding fixture.
5. Put rotary valve (Item 7) on shaft spline with "T" shaped slots on first.

6. Next put IGR inner member on shaft spline with semi-circular roll pockets between rotary valve ports.

7. Put contour member of IGR over inner and insert seven rolls into inner pockets (large diameter rolls).

8. Lightly oil square ring seal (Item 4) and put in body groove.

9. Put check balls (Item 6) over the two 1/8" inch diameter holes in body. Be sure the check balls do not fall into body tapped holes.

10. Put locating ring section (4.5 inch diameter) of IGR (Item 5) onto body with check ball holes facing downward over balls. Align the eight bolt holes in locating ring with eight holes in body. The holes align in only one position.

NOTE: Be sure not to dislodge body square ring seal while moving locating ring.

11. Install the eight locating ring rollers into their pockets and oil lightly.

12. Put other lightly oiled square ring seal (Item 4) into groove in cover and put cover over shaft end and align bolt holes.

13. Install the eight bolts with lightly oiled thread ends into bolt holes and tighten diagonally to 30 ft-lb.

NOTE: The shaft may not turn freely after assembly. A short running period may be required.





Table of Contents

WIRING SCHEMATICS AND DIAGRAMS . . . . . 2  
    Logic Chart . . . . . 2  
    Controller lights . . . . . 3  
SPECIAL TOOLS . . . . . 5  
TROUBLESHOOTING . . . . . 7  
    Starting Problems . . . . . 7  
    General Run and Transport Problems. . . . . 9  
    Aerate Operation Problems. . . . . 11  
    Safety Interlock System Problems . . . . . 13  
TESTING . . . . . 15  
    Verify Safety Interlock System Operation . . . . . 15  
    Clutch Engagement /  
    Electronic Control System Test . . . . . 16  
    Ignition Key Switch . . . . . 17  
    Controller. . . . . 18  
    Traction Switch 1 and 2. . . . . 18  
    Wheel Position Switch. . . . . 19  
    Aerator Engage and Disengage Switches . . . . . 19  
    Lift Switch . . . . . 22  
    Linear Actuator . . . . . 20  
    Brake Switch . . . . . 20  
    Pressure Gauge/Switch. . . . . 21  
    Accumulator Charge and High Press. Switches 21  
    Relays . . . . . 21  
    Battery . . . . . 22  
    Pump Clutch . . . . . 23  
    Valve Clutch. . . . . 23  
    Circuit Breaker and Fusible Link . . . . . 23  
REPAIRS . . . . . 24  
    Battery Service . . . . . 24  
    Traction Switch 1 and 2  
        Replacement and Adjustment . . . . . 25  
    Controller Replacement. . . . . 26  
    Linear Actuator Replacement . . . . . 27

# Wiring Schematics and Diagrams

## Logic Chart

Each line on the Logic Chart shows the combination of switch conditions that must be made for the listed action to occur. Example - START, under ACTIONS: For the engine to start the Key Switch must be moved to Start (making terminals B + L + S) and the hydraulic pump must be in Neutral (Traction Switch 1 CLOSED).

ACTIONS	SWITCHES													
	Start - Key Switch B + L + S	Run - Key Switch B + L + A	Traction Switch 1	Oil Pressure Switch	Water Pressure Switch	Wheel Position Switch	Accumulator Charge Switch	Traction Switch 2	Aerator Start (Engage) Switch	Aerator Stop (Disengage) Switch	Lift Switch UP (Transport)	Lift Switch DOWN (Aerate)	Accumulator High Press Switch	Brake Switch
1. Start	X		X											
2. Run		X		X										
3. Machine Lower (aerate position)		X									O	X		
4. Aerate (see Controller Timing below)														
Machine Moving (out of neutral)		X			X	X	X	X	⊗	X			O	
Machine Stationary (neutral)		X			X	X	X		X	X			O	
5. Machine Raise (transport position)		X									X	O		

### Controller Timing

#### Aerate START-UP Sequence

1. Pump clutch engages immediately.
2. Valve clutch engages 5 seconds after pump clutch engages.

#### Aerate SHUT-DOWN Sequence (Neutral Delay)

1. Pump clutch disengages and green light goes off 4 seconds after transport switch opens (red light goes off).
  2. After another 3 seconds, valve clutch will disengage.
- NOTE: Keeping aerate start (engage) switch pushed in (closed) will keep green light on and override neutral delay shut-down.

#### Aerate SHUT-DOWN Sequence (Disengage Delay)

1. Pump clutch disengages and green light goes off immediately when stop (disengage) switch is pushed in (opens) or if pump start limit switch or water pressure switch opens (yellow light goes off).
2. After another 3 seconds, valve clutch will disengage.

## Contoller Lights

Lights (LEF's) on the controller indicate when the following inputs are made to the controller:

Red: Traction switch 1 closed (traction bail in neutral).

Green: Aerate start (engage) switch closed. If red and yellow lights are on, green light will stay on until either red or yellow goes off.

Yellow: Wheel position switch closed (machine lowered to aerate position), water pressure switch closed (water pressure of more than 30 psi) and accumulator charge pressure switch closed (nitrogen pressure more than 1800 psi).

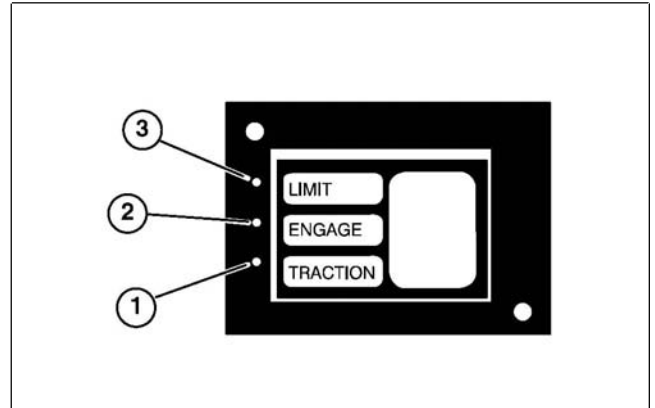

1. Red Light

2. Green Light

3. Yellow Light

---

## Electrical Schematic and Wiring Diagrams

See Chapter 8 - Electrical Diagrams.

# Special Tools

NOTE: Order special tools from the *TORO SPECIAL TOOLS AND APPLICATIONS GUIDE (COMMERCIAL PRODUCTS)*. Some tools may be available from a local supplier.

---

## Digital Multimeter (Fig. 6)

The meter can test electrical components and circuits for current, resistance, or voltage drop.

NOTE: Toro recommends the use of a DIGITAL meter when testing electrical circuits. The high impedance (internal resistance) of a digital meter will ensure that excess current is not allowed through the meter. Excess current can cause damage to a circuit that is not designed to carry it.

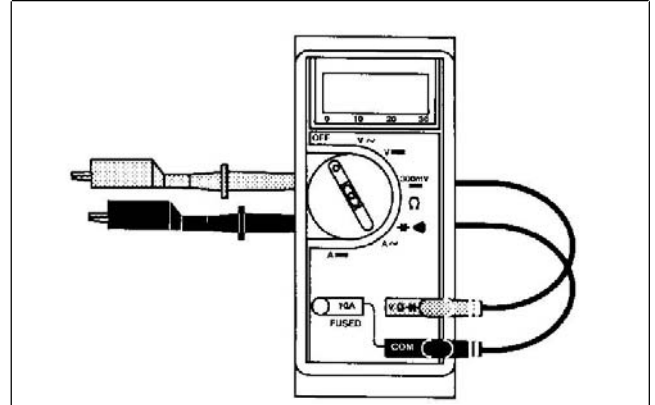

Figure 6

---

## Skin-Over Grease (Fig. 7)

Special non-conductive grease which forms a light protective skin to help waterproof electrical switches and contacts.

Toro P/N **505-47** 8 oz. (.24 L) can

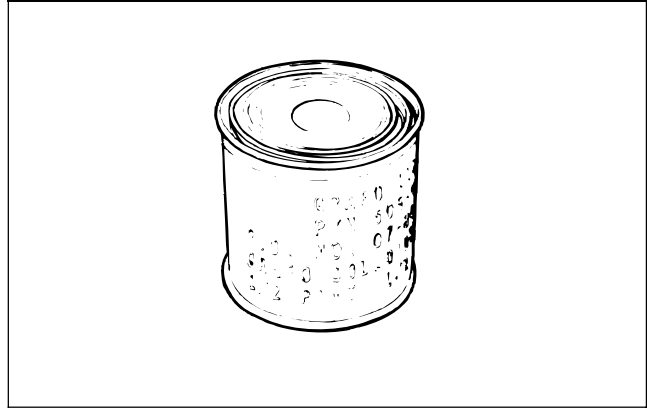

Figure 7

# Troubleshooting



**CAUTION**

**Remove all jewelry, especially rings and watches, before doing any electrical troubleshooting or testing. Disconnect the battery cables unless the test requires battery voltage.**

For effective troubleshooting and repairs, you **MUST** have a good understanding of the electrical circuits and components used on this machine. (See Electrical Schematic.)

Study the operating characteristics preceding the electrical failure to help identify the area of difficulty. Try to isolate the failure to a specific functional system; then check that area, repairing one component at a time. Attempting to repair more than one system at one time will lead to confusion.

Possible Causes and Corrections in the troubleshooting charts should be checked in the order in which they are listed.

If the machine being repaired has any interlock switches by-passed, they must be reconnected for proper troubleshooting and safety.

---

## Starting Problems

Condition	Possible Cause	Correction
Engine fails to crank, regardless of traction bail position.	Loose or corroded battery connections.	Clean and tighten connections.
	Low battery charge.	Charge battery. Replace battery if it will not hold a charge (also see Battery does not charge under General Run and Transport Problems).
	Circuit breaker open.	Reset circuit breaker. Find cause for open circuit breaker and correct. Replace circuit breaker if faulty.
	Ignition key switch faulty.	Test switch and replace if faulty.
	Traction switch 1 faulty.	Make sure switch is properly installed and adjusted. Test switch and replace if faulty.
	Start relay faulty.	Test relay and replace if faulty.
	Starter solenoid faulty.	Test starter solenoid and replace if faulty.
	Starter is faulty.	Test starter and repair replace if faulty.
	Engine is seized.	Repair engine.
	Loose or damaged wiring.	Check connections. Repair wiring.

## Starting Problems (continued)

Condition	Possible Cause	Correction
Engine cranks, but does not start. NOTE: If engine cranks, cause of problem is UNRELATED to interlock system.	Engine wire harness loose.  "L" terminal on ignition key switch loose.  Engine problem, or no fuel.	Connect wires.  Connect wire.  Find problem and correct (see Chapter 3 - Engine).
Engine cranks (but should not) with traction bail in neutral.	See Safety Interlock System Problems.	
Engine starts, but shuts down when ignition key switch is released to RUN position.	Not electrical - regulate choke during cold start-up.  Not electrical - low engine oil pressure.  Oil pressure switch faulty.  Loose or broken wire in oil pressure switch circuit.	Normal condition.  Find and correct cause of low engine oil pressure.  Test switch and replace if faulty.  Check all wiring and connections and repair as necessary.
Starter does not disengage when key switch is released to RUN position.	Ignition switch faulty.  Short in start circuit wiring.  Start relay faulty.  Starter solenoid faulty.  Starter failed (mechanical).	Test ignition key switch and replace if faulty.  Check all wiring and connections and repair as necessary.  Test start relay and replace if necessary.  Test starter solenoid and replace if necessary.  Test starter and replace if necessary.

## General Run and Transport Problems

Condition	Possible Cause	Correction
Engine shuts down during transport or when idling (not in Aerate mode).	<p>Not electrical - low engine oil pressure, no fuel, etc.</p> <p>Oil pressure switch faulty.</p> <p>Loose or broken wire in oil pressure switch circuit.</p>	<p>Find and correct cause of engine shut down.</p> <p>Test switch and replace if faulty.</p> <p>Check all wiring and connections and repair as necessary.</p>
Engine does not stop when ignition key switch is rotated to OFF position.	<p>Engine timing or carburetor out of adjustment.</p> <p>Ignition switch faulty.</p> <p>Short in ignition circuit wiring.</p>	<p>Adjust carburetor or engine timing.</p> <p>Test ignition switch and replace if faulty.</p> <p>Check all wiring and connections and repair as necessary.</p>
Battery does not charge.	<p>Loose or damaged wire(s) in engine electrical system.</p> <p>Regulator or engine charging circuit faulty.</p> <p>Battery faulty.</p>	<p>Check wiring and connections and repair as necessary.</p> <p>Repair engine charging circuit.</p> <p>Test battery and replace if faulty.</p>
Machine does not lower (to aerate position).	<p>Lift/lower switch faulty.</p> <p>Ignition key switch faulty.</p> <p>Loose or broken wire in lift down circuit.</p> <p>Linear actuator faulty.</p>	<p>Test switch and replace if faulty.</p> <p>Test ignition switch and replace if faulty.</p> <p>Check all wiring and connections and repair as necessary.</p> <p>Test actuator and repair or replace if faulty.</p>

---

## General Run and Transport Problems (continued)

Condition	Possible Cause	Correction
Machine does not raise (to transport position).	Lift/Lower switch faulty. Ignition key switch faulty. Lose or broken wire in lift up circuit. Linear actuator faulty.	Test switch and replace if faulty.  Test ignition switch and replace if faulty.  Check all wiring and connections and repair as necessary.  Test actuator and repair or replace if faulty.

## Aerate Operation Problems

Condition	Possible Cause	Correction
Machine continues to aerate (but should not) with traction bail in neutral.	See Safety Interlock System Problems.	
Machine aerates (but should not) with machine raised in transport position.	See Safety Interlock System Problems.	
Machine starts aerating (but should not) with inlet water pressure of less than 20 to 30 PSI, or machine does not stop aerating if inlet water pressure drops to 10 PSI.	Water pressure switch faulty. Water pressure switch wiring faulty. Controller faulty.	Test switch and replace if faulty. Check for short in pressure switch/controller connections and wiring and repair as necessary. Replace controller.
Machine does not start aerating when engage button is pushed in (pump drive belt does NOT rotate).	Problem not electrical (see Chapter 6 - Water System.) Loose or broken wire. Accumulator charge switch faulty. Accumulator high pressure switch faulty. Pressure gauge switch faulty. Pump clutch faulty. Pump relay faulty. Aerator stop (disengage) switch faulty. Wheel position switch faulty. Aerator start (engage) switch faulty. Controller faulty.	Check all connections and wiring and repair as necessary. Test switch and replace if faulty. Accumulator high pressure switch faulty. Test switch and replace if faulty. Test clutch and replace if faulty. Test relay and replace if faulty. Test switch and replace if faulty. Make sure switch is installed properly. Test switch and replace if faulty. Test switch and replace if faulty. Replace controller.

## Aerate Operation Problems (continued)

Condition	Possible Cause	Correction
<p>Machine does not start aerating when engage button is pushed in (pump belt IS rotating, but gear-case drive shaft is NOT rotating).</p>	<p>Valve clutch out of adjustment.</p> <p>Loose or broken wire in valve clutch / controller circuit.</p> <p>Valve clutch faulty.</p> <p>Valve clutch relay faulty.</p> <p>Controller faulty.</p>	<p>Check air gap on valve clutch and adjust if necessary.</p> <p>Check all connections and wiring and repair as necessary.</p> <p>Test valve clutch and repair or replace if faulty.</p> <p>Test relay and replace if faulty.</p> <p>Replace controller.</p>
<p>Machine stops aerating when not moving (traction bail in neutral).</p>	<p>It is normal for pump clutch and water clutch to disengage when traction bail is neutral for 3 to 4 seconds.</p>	<p>Educate operator. NOTE: Holding Aerate start switch in ENGAGE position will override neutral delay shut-down.</p>
<p>Machine stops aerating while machine is moving (traction bail out of neutral).</p>	<p>Problem not electrical (see Troubleshooting in Chapter 6 - Water System.)</p> <p>Traction switch 2 faulty.</p> <p>Loose or broken wire in traction switch / controller circuit.</p> <p>Also see possible causes in (Water pump clutch does not engage) and (Water pump clutch engages, but water valve clutch does not engage.)</p>	<p>Make sure switch is installed and adjusted properly. Test switch and replace if faulty.</p> <p>Check all connections and wiring and repair as necessary.</p>

## Safety Interlock System Problems

Condition	Possible Cause	Correction
<p>Engine cranks (but should not) with traction bail in neutral.</p>	<p>Traction switch 1 faulty.</p> <p>Traction switch 1 wiring faulty.</p>	<p>Make sure switch is installed and adjusted properly. Test neutral switch and replace if faulty.</p> <p>Check for short in switch wiring and connections and repair as necessary.</p>
<p>Machine continues to aerate (but should not) with traction bail in neutral.</p>	<p>Red light on controller is ON (should be OFF) with traction bail in neutral.</p> <p>Green light on controller stays ON (should be OFF) with aerate engage switch released.</p> <p>Controller faulty.</p>	<p>Make sure traction switch 2 is installed and adjusted properly. Test switch and replace if faulty.</p> <p>Check for short in traction switch 2/controller connections and wiring and repair as necessary.</p> <p>Test aerate engage (start) switch and replace if faulty (make sure switch action is momentary and comes back out after being pushed in).</p> <p>Replace controller.</p>
<p>Machine aerates (but should not) with machine raised in transport position.</p>	<p>Yellow light on controller is ON (should be OFF) with machine raised in transport position.</p> <p>Controller faulty.</p>	<p>Test wheel position switch and replace if faulty.</p> <p>Check for short in wheel position switch connections and wiring and repair as necessary.</p> <p>Replace controller.</p>

## Safety Interlock System Problems (continued)

Condition	Possible Cause	Correction
<p>No lights on controller come on when troubleshooting interlock system.</p>	<p>Battery is dead or disconnected.</p> <p>Circuit breaker open.</p> <p>Faulty controller ground.</p> <p>Ignition key switch faulty.</p> <p>Loose or damaged wiring in key switch/controller circuit.</p> <p>Controller faulty.</p>	<p>Charge battery. Replace battery if it will not hold a charge. Clean and tighten connections.</p> <p>Reset circuit breaker. Find cause for open circuit breaker and correct. Replace circuit breaker if faulty.</p> <p>Check controller ground connection and wiring and repair as necessary.</p> <p>Test ignition switch and replace if faulty.</p> <p>Check all connections and wiring and repair as necessary.</p> <p>Replace controller.</p>
<p>Green light on controller glows faintly when only red light should be on (traction bail out of neutral and aerate engage switch released).</p>	<p>Normal condition.</p>	

# Testing

It is often to the technician's advantage to leave the components intact in the electrical system, and by studying the electrical troubleshooting charts and schematics, determine which component is at fault. However, this section will define given components, and the tests that can be performed on those components, when those parts are disconnected from the electrical system.

For accurate resistance and/or continuity checks, electrically disconnect the component being tested from the circuit.



**CAUTION**

**When testing electrical components for continuity with a volt-ohm meter or continuity tester, make sure that power to the circuit has been disconnected.**

NOTE: Electrical troubleshooting of any 12 Volt power connection can also be performed through voltage drop tests without disconnection of the component.

---

## Verify Safety Interlock System Operation

The safety interlock system prevents the engine from cranking or starting, unless traction bail is in NEUTRAL and prevents the water system from engaging if machine is in the transport (raised) position. It also stops aeration if traction bail is released while operating or if machine is raised to the transport position.



**CAUTION**

**The interlock switches are for the operator's protection, so DO NOT disconnect them. Check operation of switches daily to make sure interlock system is operating. If a switch is defective, replace it before operating. Regardless if switches are operating properly or not, replace interlock switches every two (2) years to assure maximum safety. Do not rely entirely on safety switches; use common sense!**

### To do a functional check of interlock system:

1. Put machine in a flat, open area on rough turf away from buried wires, plumbing, etc. Stop the engine.
2. Move traction bail up and down while trying to start the engine. If engine cranks there is a malfunction in the interlock system that must be corrected. If engine does not crank, go to step 3.

3. Connect water supply to machine. Turn on water supply and bleed all air out of the system. Water pressure must be 20 to 30 PSI or more. Start the engine. Raise machine to transport position (up off of rollers). Push aerate ENGAGE button. If water pump engages and machine begins aerating, there is a malfunction in the interlock system that must be corrected. If machine does not begin aerating, go to step 4.

4. Lower machine to aerate position (on rollers). Engage traction bail to start machine moving. Push, then release aerate ENGAGE button. Water pump should engage immediately, then machine should begin aerating 5 seconds after pump engages. Release traction bail to neutral position so machine stops moving. The water pump should disengage 4 seconds after traction bail returns to neutral, then stop aerating after another 3 seconds. If machine does not stop aerating when traction bail returns to neutral, there is a malfunction in the interlock system that must be corrected. If machine stops aerating, go to step 5.

5. Engage traction bail to start machine moving, then push aerate ENGAGE button to begin aerating. Push aerate DISENGAGE button. The water pump should disengage immediately, then stop aerating after 3 seconds. If machine does not stop aerating, there is a malfunction in the interlock system that must be corrected.

## Clutch Engagement / Electronic Control System Test (Fig. 8)

This test can be used to check for proper operation of the electronic control system and clutches without connecting the machine to a water source or operating the machine.

1. Park machine on a level surface, stop the engine, engage the parking brake, open the hood and disconnect the engine spark plug wires.

2. Disconnect wiring harness connector from bottom of water pressure gauge. Install a jumper wire across terminals of disconnected wire connector. This will electrically by-pass the water pressure switch.

3. Turn ignition key switch to ON position. DO NOT start the engine.

4. ENGAGE test:

A. Lower machine to aerate position (on rollers). Yellow light should be ON.

B. Move traction bail out of neutral. Red light should come ON.

C. With traction bail out of neutral, push, then release, green aerate ENGAGE button. Green light should come ON and pump clutch should engage. After 5 seconds valve clutch should engage.

NOTE: Touch clutches with a metal object, such as a screw driver, to help check for clutch engagement (clutch will be magnetized).

5. NEUTRAL shut-down test:

A. Release traction bail. Red light should turn OFF.

B. After 4 seconds, pump clutch should disengage and green light should go OFF.

C. After another 3 seconds, valve clutch should disengage.

6. DISENGAGE test:

A. Move traction bail out of neutral and push green aerate ENGAGE button.

B. After clutches are engaged, push red aerate DISENGAGE button.

C. Green light should immediately turn OFF and pump clutch should disengage.

D. After 3 seconds, valve clutch should disengage.

E. System must not restart without pushing green aerate ENGAGE button.

**IMPORTANT: When test is completed, water pressure switch by-pass must be removed to prevent damage to water system from low inlet water pressure.**

7. Remove by-pass jumper wire that was connected in step 2 and connect wire harness connector to terminals on bottom of water pressure gauge.

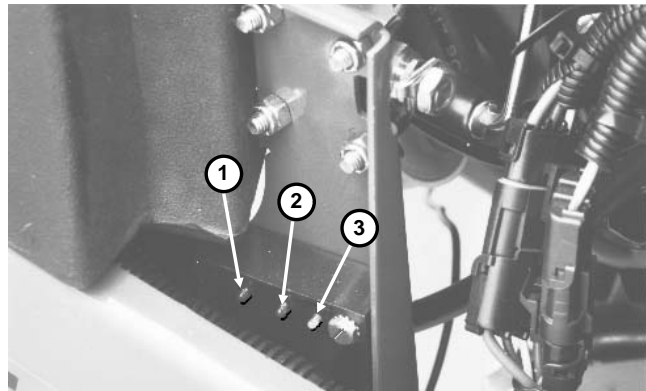

Figure 8A

- 1. Red light
- 2. Green light
- 3. Yellow light

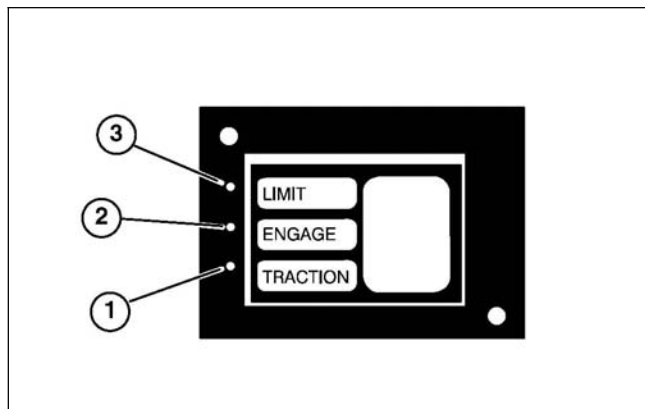

Figure 8B

- 1. Red light
- 2. Green light
- 3. Yellow light

## Ignition Switch

The ignition (key) switch has three positions (OFF, RUN, and START) (Fig. 9). The terminals are marked as shown in Figure (Fig. 9a).

### Testing

The circuitry of the ignition switch is shown in the chart below. With the use of a multimeter (ohms setting), the switch functions may be tested to determine whether continuity exists between the various terminals for each switch position.

Unplug wire harness connectors from switch and verify continuity between switch terminals. Reconnect the harness connectors to the switch after testing.

POSITION	CIRCUIT
OFF	G + M + A
RUN	B + L + A
START	B + L + S

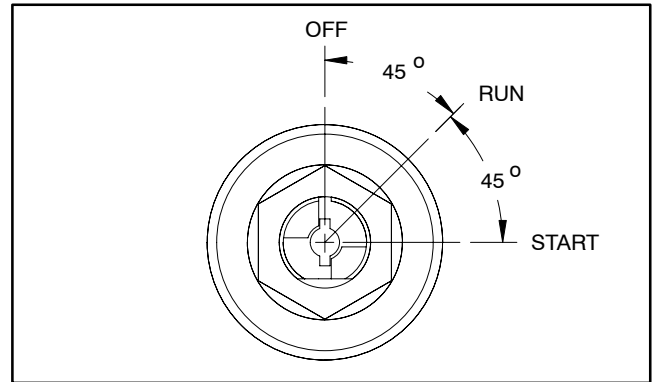

Figure 9

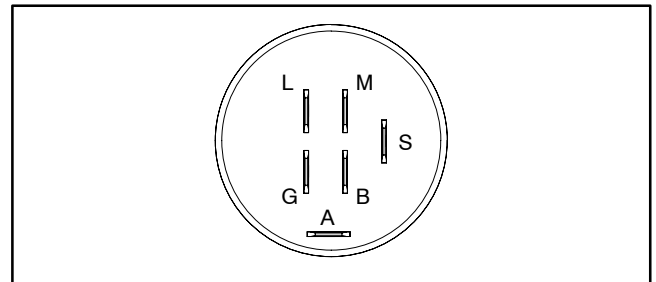

Figure 9a

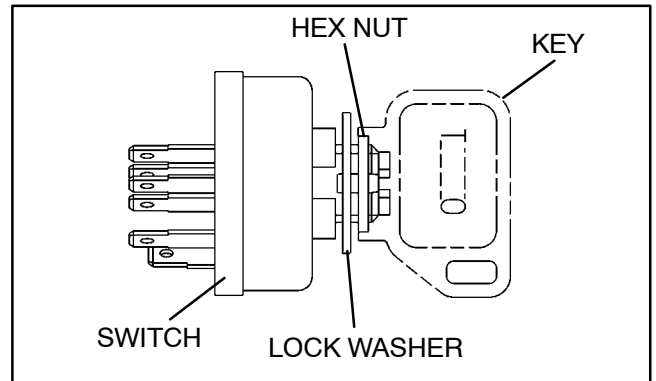

Figure 10

---

## Controller (Fig. 11)

The controller senses the condition of various switches, such as the transport switch and aerate start switch and directs power output to allow certain machine functions, such as aerate engage, disengage and timing of those functions.

Because of the solid state circuitry built into the controller, there is no method to test it directly. The controller may be damaged if an attempt is made to test it with an electrical test device, such as a volt-ohm meter.

**IMPORTANT: Before welding on the machine, disconnect both battery cables from the battery, disconnect both wire harness plugs from the electronic control unit and disconnect the terminal connector from the alternator to prevent damage to the electrical system.**

Lights (LED's) on the controller indicate the condition of the interlock switches. The LED's, in conjunction with the following tests for interlock switches, should be used to help isolate a problem in an interlock switch, wiring or the controller (see Wiring Schematics and Diagrams).

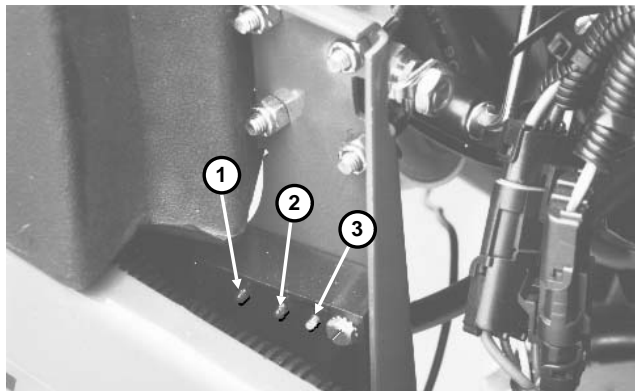

Figure 11

1. Red light
2. Yellow light
3. Green light

---

## Traction Switch 1 and 2 (Fig. 12)

Traction switch 1 is normally open (N.O.) and is closed when traction bail is neutral. Traction switch 2 is normally closed (N.C.) and is open when the traction bail is in neutral.

**IMPORTANT: Traction switch 1 and 2 have three (3) terminals. Traction switch 1 must have the wires connected to the "COMMON" and "N.O." terminals. The Traction switch 2 must have the wires connected to the "COMMON" and "N.C." terminals. If the wires are not connected to the correct terminals, on each switch the safety interlock circuit will not function properly.**

Test the switch by disconnecting the wires from the switch terminals and connecting a continuity tester across the two terminals that had wires connected to them. With the engine turned off, slowly push the traction bail in a forward and reverse direction while watching the continuity tester. There should be indications that the switch is opening and closing. Allow the traction bail to return to neutral. There should be continuity across the terminals of traction switch 1 and no continuity across the terminals of the traction switch 2. (See Traction Switch 1 and 2 Replacement and Adjustment in the Repairs section of this chapter for replacement and adjustment procedures.)

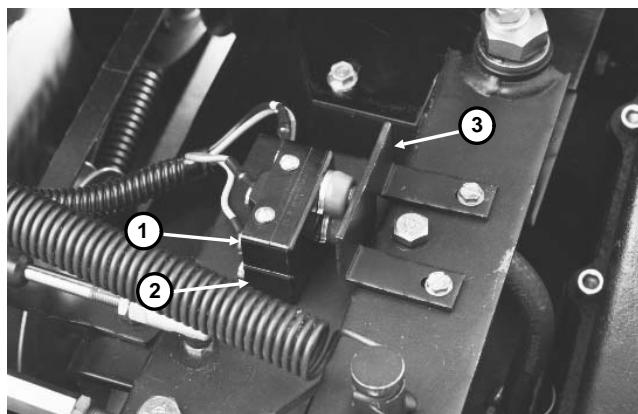

Figure 12

1. Traction switch 1 — N.O. (gray & black wires)
2. Traction switch 2 — N.C. (orange & yellow wires)
3. Switch tab

## Wheel Position Switch (Fig. 13)

Test the switch by disconnecting the wire connector and installing a continuity tester or ohm meter across the two leads of the switch.

Wheel Position Switch	
Aerate (machine lowered)	Transport (machine raised)
CLOSED	OPEN

NOTE: For proper operation, the switch must be screwed all the way in. A damaged pivot shaft or bushings could cause the switch to not open and close properly. Debris in the switch could also cause it to not open and close properly.

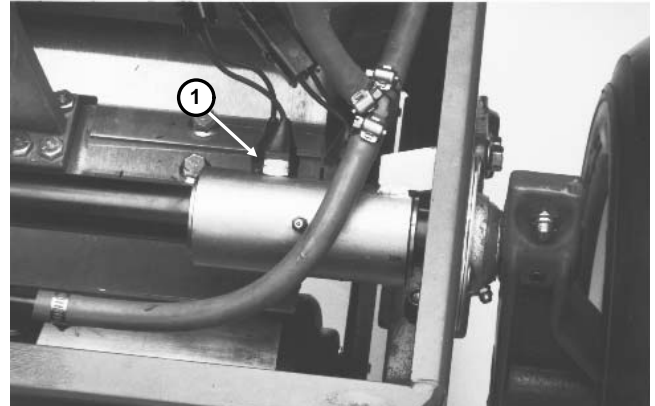

Figure 13

1. Wheel position switch

## Aerator Start and Stop (Water Engage and Disengage) Switches (Fig. 14)

The aeration start (ENGAGE) switch is normally open (N.O.) and closes when the button is pushed down. The aeration stop (DISENGAGE) switch is normally closed (N.C.) and opens when the button is pushed down.

Test the switch by disconnecting the wires from the switch terminals and connecting a continuity tester or ohm meter across the two switch terminals.

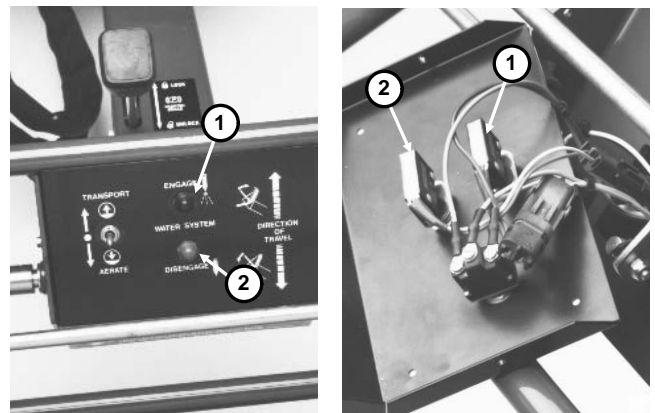

Figure 14

1. Aeration start (engage) switch (pink & orange wires)
2. Aeration stop (disengage) switch (gray & white wires)

## Lift Switch (Fig. 15)

The lift switch is a three position switch. Switch position is maintained in center position with no circuits made.

Test the switch by disconnecting the wires from the switch terminals and connecting a continuity tester or ohm meter across the terminals.

Terminals 2-3 and 5-6 should have continuity in UP.

Terminals 2-1 and 5-4 should have continuity in DOWN.

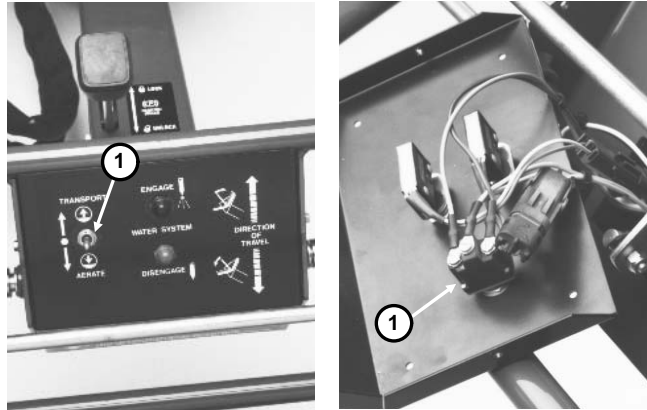

Figure 15

1. Lift switch

## Linear Actuator (Fig. 16)

The linear actuator has a bi-directional electric motor which engages a clutch and screw mechanism to extend or retract a rod and raise or lower the transport wheels.

To test the actuator:

1. Disconnect the wiring connector.

2. Connect a 12 volt battery so the negative (–) terminal is connected to the red wire of the actuator connector. When the positive (+) battery terminal is connected to the yellow wire the actuator motor should operate to extend the actuator cylinder, raising the wheels to aerate position.

3. Connect a 12 volt battery so the negative (–) terminal is connected to the yellow wire of the actuator connector. When the positive (+) battery terminal is connected to the red wire the actuator motor should operate to retract the actuator cylinder, lowering the wheels to transport position.

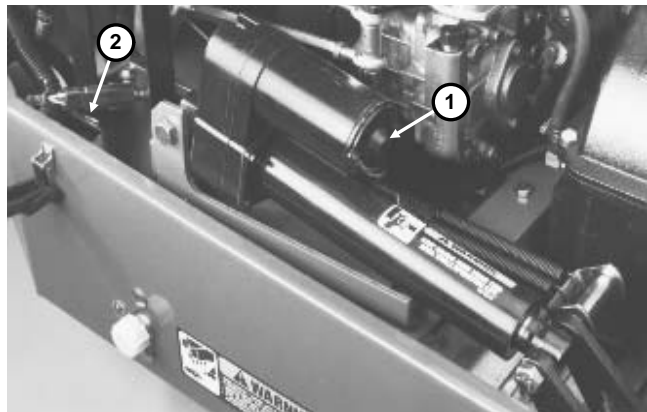

Figure 16

1. Linear actuator

2. Wiring connector

Linear Actuator Specifications	
Rod end play	0.070 max.
Current draw	26 amps max.
Voltage	12 VDC
Speed	3/4 in. per second at maximum load

## Brake Switch (Fig. 17)

The brake switch is a normally open (N.O.) switch that closes when the brake is engaged.

To test the brake switch disconnect the wires from the switch terminals and connect a continuity tester or ohm meter across the terminals of the switch. With the brake disengaged, the switch should show no continuity. With the brake engaged, the switch should show continuity.

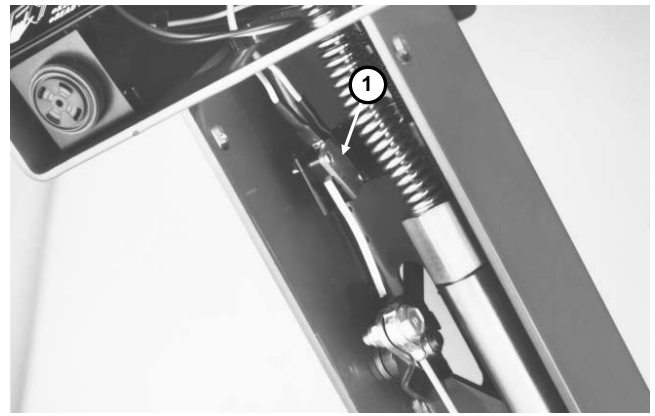

Figure 17

1. Brake switch

## Pressure Gauge/Switch (Fig. 18)

The pressure gauge switch is normally open and closes when inlet water pressure goes above 20 to 30 PSI. The switch opens when inlet water pressure goes below approximately 10 PSI.

To test the pressure switch, disconnect the wire connector and connect a continuity tester or ohm meter across the terminals of the switch connector. The switch should show continuity when inlet water pressure reaches 20 to 30 PSI on gauge. The switch should break continuity as water pressure goes below 10 PSI.

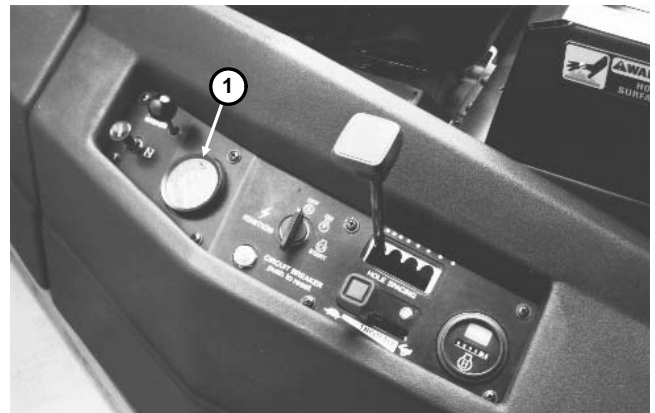

Figure 18

1. Pressure gauge/switch

## Accumulator Charge and High Pressure Limit Switches (Fig. 18a)

The accumulator charge switch is normally open and closes when accumulator charge pressure is greater than 1800 PSI. The switch opens when accumulator charge pressure goes below 1400 PSI.

The high pressure limit switch opens at 5500 PSI (rising pressure) and closes at 5350 PSI (falling pressure).



**DANGER**

**The accumulator contains nitrogen gas under high pressure. DO NOT attempt to remove or replace these switches without first opening the high pressure water bleed valve and then releasing pressurized gas from the accumulator (see Accumulator Service in Chapter 6 - Water System).**

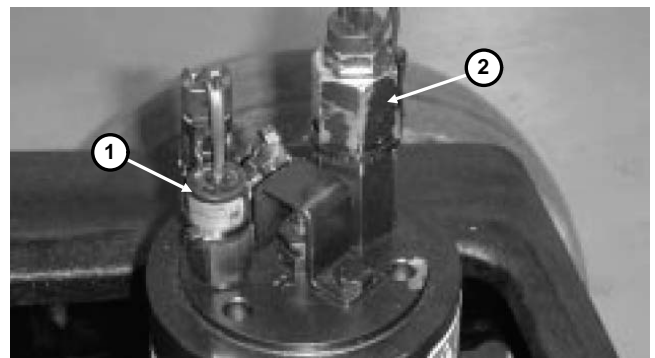

Figure 18a

1. High pressure limit switch      2. Accumulator charge switch

---

## Relays (Fig. 19, 20)

To test a relay, disconnect the relay wire connector and install a continuity tester between the relay terminals (terminals 30 and 87). The relay should make and break continuity at terminals 30 and 87 as 12 V.D.C. is connected and disconnected to terminal 85 with terminal 86 connected to ground.

Resistance specifications:

Terminals 85 and 86 = 80 to 90 Ohms

Terminals 30 and 87a (normally closed) = continuity

Terminals 30 and 87 (normally open) = continuity when 12V DC is applied to terminals 85 and 86



Figure 19

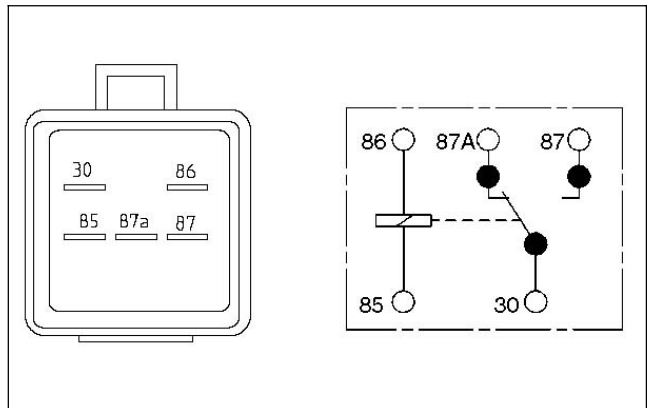

Figure 20

---

## Battery

Use a hydrometer to test the battery. Charge the battery if necessary (see Battery Service).

Electrolyte Specific Gravity

Fully charged: 1.250 - 1.280

Discharged: less than 1.240

---

## Pump Clutch (Fig. 21)

To test the pump clutch, disconnect the wire connector and connect a continuity tester or ohm meter across the terminals of the clutch wire connector. There should be continuity across the terminals of the clutch connector. Resistance measured through the clutch coil should be approximately 3 ohms.

The clutch can also be tested by connecting a 12 VDC battery across the clutch connector terminals. The clutch should engage as 12 VDC is connected to the clutch connector terminals.

Clutch coil resistance:

3.79 Ohms  $\pm$  5% at 20°C (68° F)

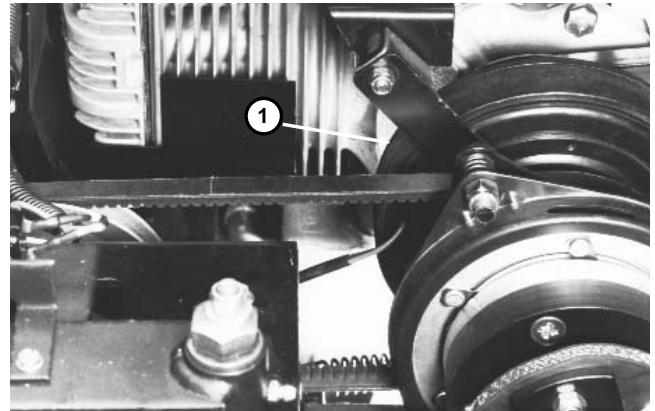

Figure 21

1. Pump clutch

---

## Valve Clutch (Fig. 22)

To test the valve clutch, disconnect the wire connector and connect a continuity tester or ohm meter across the terminals of the clutch wire connector. There should be continuity across the terminals of the clutch connector. Resistance measured through the clutch coil should be approximately 3 ohms.

The clutch can also be tested by connecting a 12 VDC battery across the clutch connector terminals. The clutch should engage as 12 VDC is connected to the clutch connector terminals.

Clutch coil resistance:

3.5 Ohms  $\pm$  5% at 20°C (68° F)

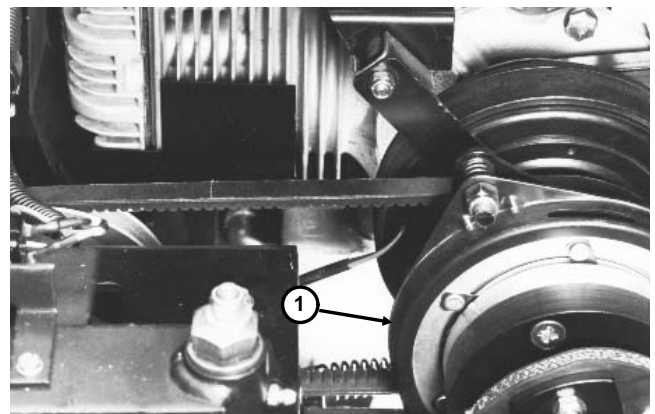

Figure 22

1. Valve clutch

---

## Circuit Breaker and Fusible Link (Fig. 23)

The electrical system is protected by a 20 AMP circuit breaker with reset button and a fusible link.

To test the circuit breaker, check for continuity between the two terminals.

The fusible link is located in the control panel wiring harness between the circuit breaker and starter B+ terminal. To test the fusible link, check for continuity between terminals J22 and J23 of the control panel wiring harness (see Schematic and Control Panel Wiring Harness in Chapter 8 - Electrical Diagrams).

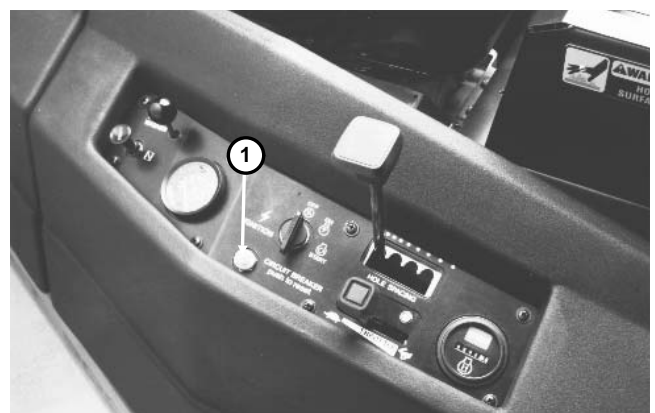

Figure 23

1. Circuit breaker

# Repairs

## Battery Service (Fig. 24, 25)

**IMPORTANT: To prevent damage to the electrical components, do not operate the engine with the battery cables disconnected.**

Keep the terminals and entire battery case clean. To clean the battery, wash the entire case with a solution of baking soda and water. Rinse with clear water. Do not get the soda solution into the battery because damage to the battery will result. Coat the battery posts and cable connectors with skin-over grease, or petroleum jelly to prevent corrosion.

Check for loose battery hold-downs. A loose battery may crack or cause the container to wear and leak acid.

Check the electrolyte solution to make sure the level is above the plates. If the level is low (but above the plates inside the battery), add water so the level is to the bottom of the cap tubes. If the level is below the plates, add water only until the plates are covered and then charge the battery. After charging, fill the battery to the proper level.



**CAUTION**

**Do not charge a frozen battery because it can explode and cause injury. Let the battery warm to 60° F (15.5° C) before connecting to a charger.**

**Charge the battery in a well-ventilated place so that gases produced while charging can dissipate. Since the gases are explosive, keep open flame and electrical spark away from the battery; do not smoke. Nausea may result if the gases are inhaled. Unplug the charger from the electrical outlet before connecting or disconnecting the charger leads from the battery posts.**

Electrolyte Specific Gravity

Fully charged: 1.250 - 1.280  
Discharged: less than 1.240

Battery Specifications

BCI Group 28 Battery:  
535 Amp Cranking Performance at 0° F (-17° C)  
110 min. Reserve Capacity at 80° F (27° C)

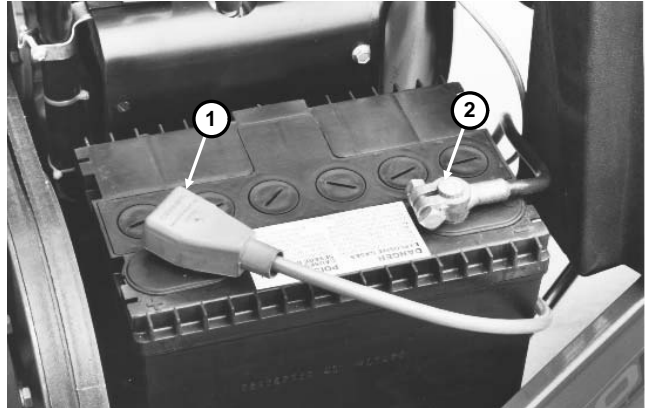

Figure 24

1. Positive (+) terminal
2. Negative (-) terminal

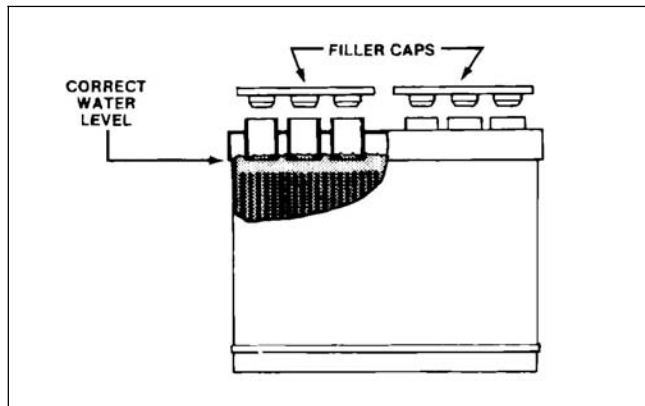

Figure 25

## Traction Switch 1 and 2 Replacement and Adjustment (Fig. 26)

1. Disconnect wires from switch terminals.
2. Have a helper push traction bail down into either FORWARD or REVERSE position or disconnect extension spring; this will take switch arm tension off of switch. Loosen two (2) screws and remove switch.
3. Have a helper push traction bail down and Install new switch. DO NOT over-tighten screws as the switch case could break.
4. Reconnect wires to new switch. Make sure one wire is connected to "COMMON" terminal, and one wire is connected to N.O. terminal (traction switch 1) or N.C. terminal (traction switch 2).

**IMPORTANT:** Traction switch 1 and 2 have three (3) terminals. If the two (2) wires are not connected to the "COMMON" and "N.O." terminals on traction switch 1 and "COMMON" and "N.C." terminals on traction switch 2, the safety interlock circuit will not function properly.



CAUTION

If the wires are not correctly installed to traction switch 1, the engine could start with the traction bail in forward or reverse.

5. Coat switch terminals and wires with skin-over grease.
6. Loosen two (2) screws and adjust switch tab so switches are actuated, but not bottomed out, when pump control is in neutral.

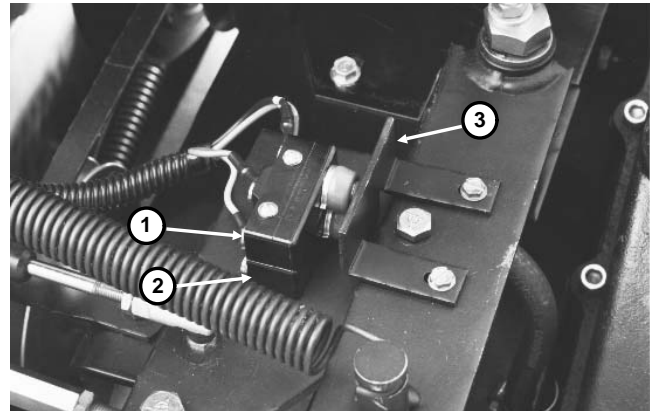

Figure 26

1. Traction switch 1 – N.O. (gray & black wires)
2. Traction switch 2 – N.C. (orange & yellow wires)
3. Switch tab

---

## Controller Replacement (Fig. 27)

**IMPORTANT:** Before welding on the machine, disconnect both battery cables from the battery, disconnect both wire harness plugs from the controller and disconnect the terminal connector from the alternator to prevent damage to the electrical system.

1. Stop the engine and disconnect battery cables from battery.
2. Disconnect wiring harness connectors from controller.
3. Remove two (2) nuts securing controller to frame and remove controller.
4. Install new controller and secure to frame with nuts removed in step 3.
5. Connect wiring harness connectors to controller.
6. Connect battery cables.

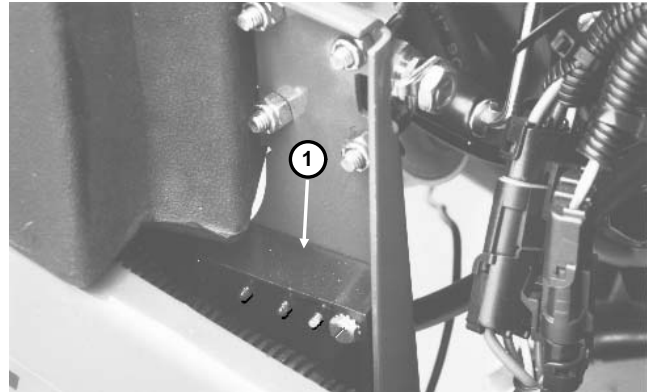

Figure 27

1. Controller

## Linear Actuator Replacement (Fig. 28)

1. Put wheels in transport position (machine raised).
2. Put the machine on a level surface, stop the engine, engage the parking brake and disconnect engine spark plug wires.
3. Open the hood.
4. Disconnect linear actuator wire connector.
5. Disconnect extension springs.
6. Remove capscrew and nut securing each end of linear actuator.
7. Reverse steps 3 - 6 to install the linear actuator.

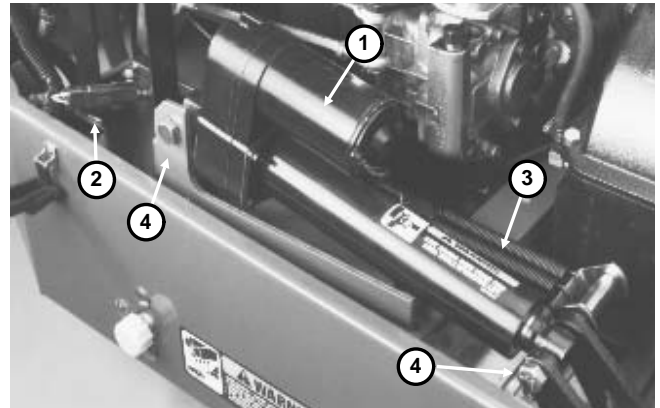

Figure 28

- |                    |                     |
|--------------------|---------------------|
| 1. Linear actuator | 3. Extension spring |
| 2. Wire connector  | 4. Capscrew & nut   |





Table of Contents

SPECIFICATIONS ..... 2  
    Nozzle Size and Approximate Depth Chart ..... 2  
WATER SYSTEM SCHEMATIC ..... 3  
SPECIAL TOOLS ..... 4  
    Accumulator Charging Valve  
    and Pressure Gauge ..... 4  
    Accumulator Seal Installation Tool ..... 4  
    Accumulator Cap Wrench ..... 5  
    Water System Pressure Gauge ..... 5  
    Flow Meter ..... 5  
    Valve Lift Indicator ..... 6  
    Valve Spring Compressor ..... 6  
    Water Valve Seal Installation Guide ..... 7  
    Pump Seal Installation Guide ..... 7  
    Seal Installation Mandril ..... 7  
    Filter Body Wrench ..... 7  
    Pump Seal Extraction Tool ..... 8  
    Pump Seal Outlet Cover ..... 8  
    Pump Wear Sleeve Driver ..... 8  
TROUBLESHOOTING ..... 9  
    Troubleshooting Water System Problems ..... 9  
TESTING ..... 12  
    Before Performing Water System Tests ..... 12  
    TEST NO. 1: Accumulator Pre-Charge Pressure  
    and Adding Dry; Nitrogen ..... 13  
    TEST NO. 2: Water System Pressure and Flow ..... 15  
    TEST NO. 3: Water Valve Lift ..... 17  
ADJUSTMENTS ..... 18  
    Electric Clutch Adjustment ..... 18  
    Water Valve Lift ..... 18  
REPAIRS ..... 20  
    Drive Coupling and Clutch  
    Removal and Installation ..... 20  
    Pump Drive Belt Replacement ..... 21  
    Water Filter Replacement ..... 22  
    Water Pump Removal and Installation ..... 23  
    Water Pump Head Service ..... 24  
    Water Pump Crankcase Service ..... 26  
    Water Valve Service ..... 29  
    Gear Case Service ..... 32  
    Nozzle Service and Replacement ..... 33  
    Accumulator Replacement ..... 34  
    Accumulator Service ..... 36  
GENERAL INFORMATION ..... 38  
    Cold Weather Storage ..... 38

# Specifications

**Water Pump Clutch:** Electromagnetic, dual groove belt drive for water pump and driveshaft flange brake/clutch for main valve gearbox.

Air gap 0.018 in.

**Pre Filter** – Spin down type with washable cartridge in clear plastic housing and plastic ball valve for flushing.

**Supply Filter** – Replaceable 5 micron cartridge in plastic housing with air bleed button.

Water Filter Cartridge: Toro part no. 86–8630

**Water Pressure Switch** – Senses for water pressure after filter.

Switch closes when pressure is over 20–28 PSI and opens when pressure drops below 7–13 PSI.

**Pump** – Toro exclusive design with cast stainless steel head and 3 piston plungers. Vee packing seals and Kevlar guides. Forged crankshaft with plasma sprayed ceramic on stainless steel plungers and cast iron connecting rods.

Nominal performance is 4 GPM at 5000 PSI with 1400 RPM input.

**Accumulator** – Toro exclusive design with low charge pressure sensor.

Charged with nitrogen gas charged to 2500 PSI maximum pressure.

Low charge pressure limit switch:  
Closes at 1800 PSI  
Opens at 1400 PSI

High operating pressure limit switch:  
Closes at 5500 PSI (rising pressure)  
Opens at 5350 PSI (falling pressure)

**Cam and Gearbox** – Reduction gear drive for cam that actuates main water valve. Roller cam follower rides on cam specifically designed (patent pending) to control water injection at 5.3 cycles per second (320 rpm) and store energy in accumulator between injections. Cast iron case also serves as 4 quart hydraulic reservoir.

**Valve** – Cast stainless steel valve body functions as mounting base for accumulator, gearbox and manifold

outlet. All high pressure water flows in and out through the valve body. Pressure balanced valve spool with floating (patent pending), hardened stainless seat aligns during assembly. Bleed valve in base allows for bleed-off of high pressure and drain down for cold weather storage. Bolted flanges and polyurethane O-rings mate all components to valve body.

Valve lift:  $0.100^{+0.002}_{-0.04}$  inch (with new cam)

**Rollers** – Pivoting aluminum rollers uniformly smooth the turf and provide protection from the nozzle discharge. Adjustable flow (0 – 3 GPM) spray wash system with 6 flood tip nozzles maintain clean rollers.

**Pressure Relief Valve** – Poppet-type valve with corrosion resistant stainless and brass materials.

5000 ± 300 PSI relief valve pressure.

**Manifold and Nozzles** – Extruded stainless steel manifold with 11 flanged nozzle extensions containing check valves and hardened stainless discharge orifice. Check valves may be reversed in housing to block unused nozzles.

**Aeration Width:** 33 inches with 11 nozzles on 3 inch centers.

**Aeration Depth:** 4 to 6 inches depending on turf conditions and nozzle configuration.

**Hole Pattern:** Variable from 1.5” to 6” spacing in the direction of travel, and 3 or 6” increments in width.

**Water Pump Case Oil** – See Operator’s Manual.

**Water Supply** – Recommend a source with 7–8 gallons per minute. A minimum pressure of 30 psi at the machine is required for the pump to engage. Maximum allowable pressure of 200 psi. Although irrigation water pumped from ponds or effluent holding pools can be used, not all conditions can be handled by the machines filtration system, additional or alternative filtration may be required.

**DO NOT USE CHEMICALS – Concern for environmental issues and corrosive affects on machine components.**

**Depths and Nozzle Configurations:** All nozzles are identified with numbers indicating the drill size of the orifice. The standard configuration is 11 nozzles producing depths of 4 to 6 inches depending on turf conditions. Blocked nozzle locations are obtained by reversing the nozzle check valve ball and spring. See nozzle size chart and illustrations below:

**IMPORTANT:** Use only nozzle configurations shown or damage to the machine may occur.

<b>NOZZLE SIZE AND APPROXIMATE DEPTH CHART</b>						
Part No.	Drill Size	Decimal Size (inch)	Metric Size (mm)	Quantity of Nozzles		Approx. Depth
				Open	Blocked **	
86-8130	#56	.0465	1.181	*	*	*
86-8131	#53	.0595	1.511	11	0	4-6"
86-8133	#46	.0810	2.057	6	5	6-8"
* Use only with varied size configurations						

Aluminum Washer is required with any nozzle change:

Part no. 86-8150

<b>OPTIONAL STAGGERED SIZE NOZZLE CONFIGURATION</b>						
Part No.	Drill Size	Decimal Size (inch)	Metric Size (mm)	Quantity of Nozzles		Approx. Depth
				Open	Blocked **	
86-8130	#56	.0465	1.181	6 and	0**	3-4"
86-8133	#46	.0810	2.057	5	0**	6-8"

Aluminum Washer is required with any nozzle change:

(S/N 29999 & Below) Part no. 80-6680

Part no. 86-8150

\*\*Additional nozzles may be blocked to compensate for pump wear.

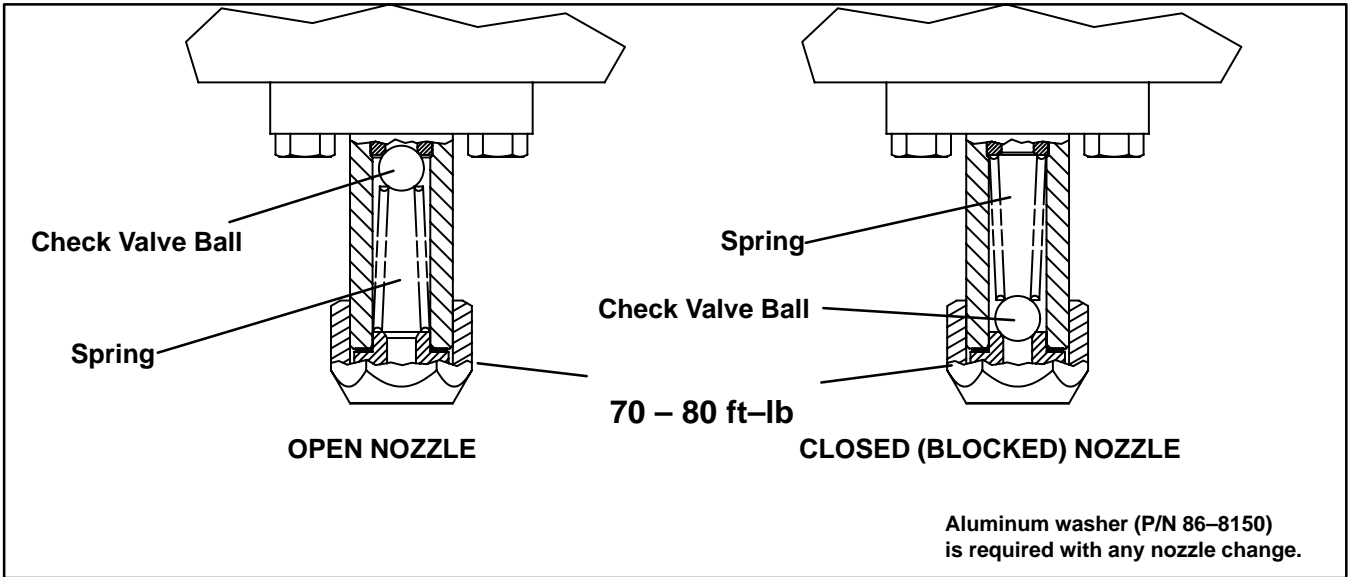

# Water System Schematic

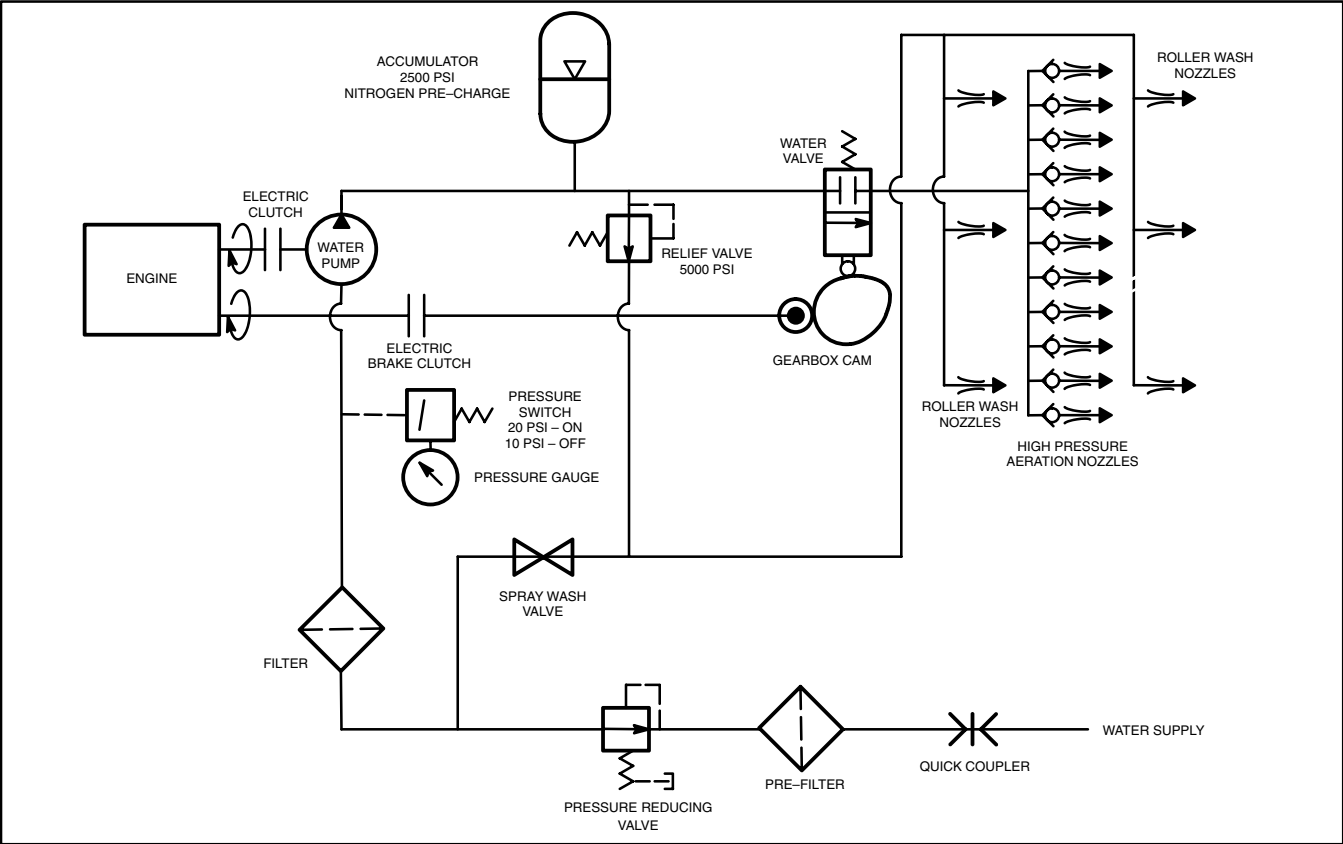

# Special Tools

The following special tools are required for servicing the HydroJect 3010.

Order special tools from the *TORO SPECIAL TOOLS AND APPLICATIONS GUIDE (COMMERCIAL PRODUCTS)*.

---

## Accumulator Charging Valve and Pressure Gauge - TOR4001 (Fig. 2)

The charging valve connects the accumulator to a high pressure (3000-3500 or 6000 PSIG) Nitrogen tank for pre-charging the accumulator. The charging valve can also be used to measure accumulator pre-charge pressure without significant loss of accumulator pre-charge.

NOTE: The charging tool is equipped with a Compressed Gas Association No. 677 tank connection.

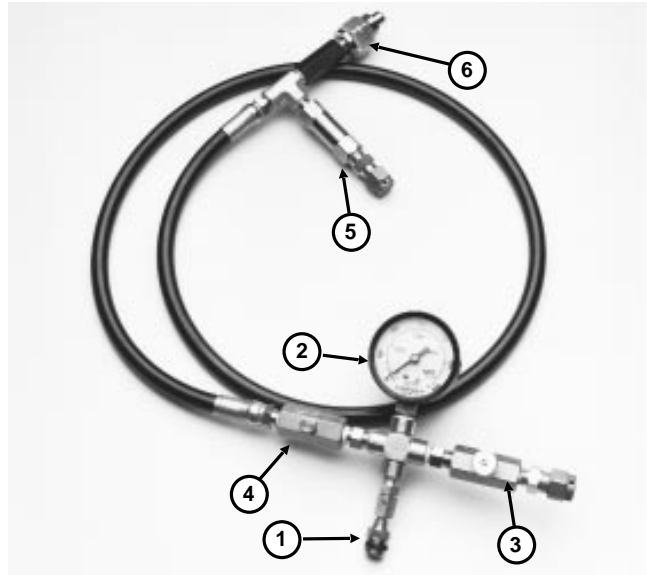

Figure 2

- |                               |                            |
|-------------------------------|----------------------------|
| 1. Accumulator connector      | 4. Inlet valve             |
| 2. Pressure gauge             | 5. Relief valve            |
| 3. Outlet valve with diffuser | 6. Nitrogen tank connector |

---

## Accumulator Seal Installation Tool - TOR4002 (Fig. 3)

Used for installing piston seal during accumulator rebuilding.



Figure 3

---

### Accumulator Cap Wrench - TOR4003 (Fig. 4)

After discharging accumulator, use this special wrench to remove accumulator cap for accumulator rebuilding.

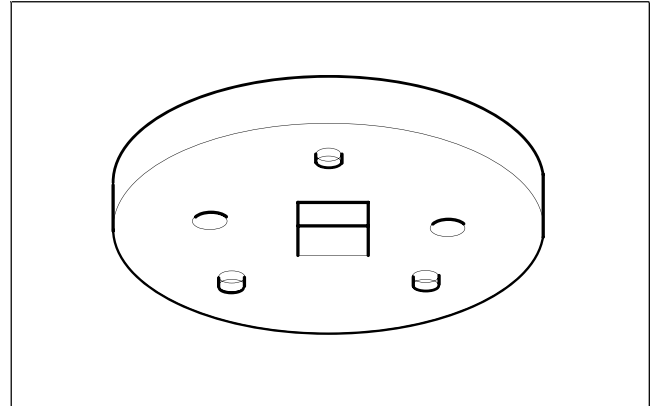

Figure 4

---

### Water System Pressure Gauge - TOR4005 (Fig. 5)

The Water System Pressure Gauge and Adapter is temporarily connected into the high pressure water system for measuring water pressure available to the water valve.



Figure 5

---

### Flow Meter - TOR4006 (Fig. 6)

The in-line flow meter with a battery-powered electronic digital display is installed in the water supply line to measure pump efficiency. The flow meter is equipped with a pressure gauge to measure inlet water pressure. This gauge used in conjunction with the pressure gauge on the machine can be used to measure pressure drop across the filter to show filter condition.



Figure 6

---

### Valve Lift Indicator - TOR4007 (Fig. 7)

A special dial indicator and adaptor is temporarily installed into the inspection port on the side of the high pressure manifold to measure water valve lift. This indicator is also used to measure cam wear and determine correct shim size to get proper valve lift.



Figure 7

---

### Valve Spring Compressor - TOR4008 (Fig. 8)

The valve spring compressor and hardware is used for compressing the water valve spring allowing removal and installation of the valve spring retainer. The spring retainer must be removed before servicing the water valve, water valve seals, and water valve seat.



Figure 8

---

## Seal Installation Tools (Fig. 9)

### Water Valve Seal Installation Guide - TOR4009

The Water Valve Installation Guide (small) is needed to properly install the water valve seal into the water valve body. Use Insertion Mandril with this seal guide.

### Pump Seal Installation Guide - TOR4010

The Pump Seal Installation Guide (large) is needed to properly install the pump displacement rod seal into the pump head. Use Insertion Mandril with this seal guide.)

### Seal Installation Mandril - TOR4011

Use Insertion Mandril with both seal guides. Seal Insertion Mandril is necessary to properly install seals in the water valve and pump head.

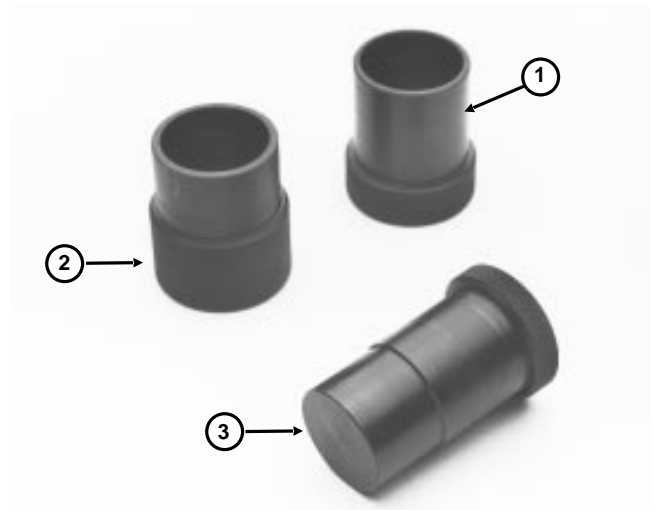

Figure 9

1. Water Valve Seal Installation Guide
2. Pump Seal Installation Guide
3. Seal Installation Mandril

---

## Filter Body Wrench - TOR4012 (Fig. 10)

Special spanner wrench use for servicing the inlet water filter.



Figure 10

---

## Pump Seal Extraction Tools (Fig. 11)

### Pump Seal Extraction Tool - TOR4013

Rod used to hydraulically extract pump seals from the pump cylinder head. Use with Pump Seal Outlet Cover and heavy mallet or hammer.

### Pump Seal Outlet Cover - TOR4014

Cover plate with O-ring used with Seal Extraction Tool to hydraulically extract pump seals from pump head.

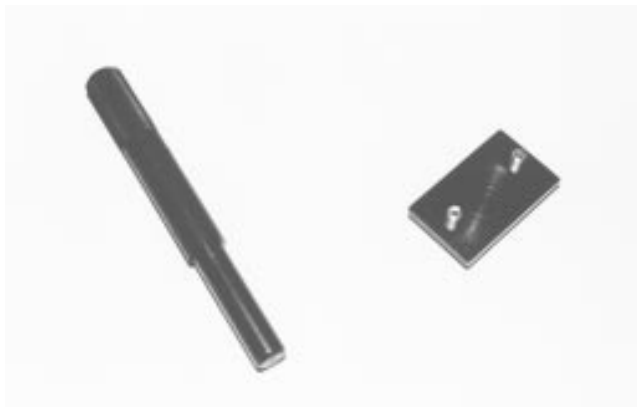

Figure 11

---

## Pump Wear Sleeve Driver - TOR4015 (Fig. 12)

Driver used for removal and installation of plunger guides in pump crankcase.



Figure 12

# Troubleshooting

The cause of an improperly functioning water system is best diagnosed with the use of proper testing equipment and a thorough understanding of the complete system.

The charts that follow contain detailed information to assist in troubleshooting. There may possibly be more than one cause for a machine malfunction.

**ALL POSSIBLE CAUSES SHOULD BE CHECKED IN THE ORDER IN WHICH THEY ARE LISTED ON THE CHARTS.**

Refer to the Testing section of this Chapter for precautions and specific test procedures.

**NOTE:** The water aeration system operates under very high pressures and severe duty cycles. Performance of the water system will be gradually reduced over a period of time due to normal wear in the pump, valve and accumulator. If you perform water system tests to isolate a possible problem, such as reduced hole depth, it is recommended that ALL tests be performed in the order listed even if the apparent problem has been isolated, such as low accumulator pre-charge pressure. This will verify that all components are operating properly.

---

## Troubleshooting Water System Problems

Condition	Possible Cause	Correction
Machine does not start aerating when engage button is pushed in (pump belt does NOT rotate).	<p>Transport wheels not fully raised (unit lowered to aerate mode).</p> <p>Low inlet water pressure.</p> <p>Sheared pump clutch key.</p> <p>Electrical problem.</p>	<p>Check to make sure transport wheel arms are fully raised (unit in aerate mode).</p> <p>Check that water pressure gauge reads 20 to 30 PSI or more. If pressure is low, obtain proper water supply source.</p> <p>Repair.</p> <p>See Troubleshooting in Chapter 5 - Electrical System</p>
Machine does not start aerating when engage button is pushed in (pump belt IS rotating but gear-case drive shaft is NOT rotating.).	<p>Electric brake clutch (valve clutch) out of adjustment.</p> <p>Sheared valve clutch key.</p> <p>Electrical problem.</p>	<p>Check air gap at electric brake clutch and adjust if necessary.</p> <p>Repair.</p> <p>See Troubleshooting in Chapter 5 - Electrical System</p>
Machine makes unusual noise when first starting aeration.	<p>Air in system. NOTE: Relief valve may "squeal" for a short period of time during initial startup due to air in the system.</p> <p>Damaged component.</p>	<p>With engine OFF and water supply connected, open high pressure bleed valve and bleed air out of system. Repeat procedure if noise continues.</p> <p>Check for damaged components and repair or replace as necessary.</p>

Condition	Possible Cause	Correction
<p>Machine stops aerating (pump shuts down during aeration).</p>	<p>Machine not moving.</p> <p>Inadequate water supply.</p> <p>Plugged inlet water filter.</p> <p>Electrical problem.</p>	<p>Normal condition of interlock system. Operator must hold engage button in to aerate with traction bail in neutral.</p> <p>Check for kinked water supply hose, restriction in line or partially open valve at water source.</p> <p>Check water pressure at gauge when pump is engaged. If pressure drops to less than 15 PSI, but was initially higher, replace water filter.</p> <p>See Troubleshooting in Chapter 5 - Electrical System</p>
<p>Water system engages (pump belt and gear case drive shaft rotate), but no aeration holes are produced or aeration hole depth is shallow or inconsistent.</p>	<p>Air in system.</p> <p>Soil density or moisture content.</p> <p>Plugged nozzles, worn nozzles or improper nozzle configuration. NOTE: Check operation of nozzles by aerating over a piece of cardboard, then inspecting cardboard.</p> <p>Gear or cam damage in gear case.</p> <p>Leak in high pressure water system.</p>	<p>With engine OFF and water supply connected, open high pressure bleed valve and bleed air out of system.</p> <p>If hole depth was satisfactory before in another area, different nozzle configuration may be required.</p> <p>Stop engine, open high pressure bleed valve, then inspect nozzles. Check for plugged nozzles. Verify size and quantity (see Nozzle Size and Approximate Depth Chart). Nozzles that are too large will cause loss in pressure and could cause damage to the accumulator and other water system components.</p> <p>Inspect gear case for gear or cam damage and repair as necessary.</p> <p>Check for leaks with water system engaged. Stop engine, open high pressure bleed valve and repair leaks as necessary.</p> <p>NOTE: Excessive water exiting between pump head and crankcase indicates pump wear or damage. Excessive water exiting from shim area below gearcase indicates valve wear or damage. Do water system tests and make repairs as necessary.</p>

Condition	Possible Cause	Correction
Machine aerates, but aeration hole depth is shallow or inconsistent (continued).	<p>Low accumulator pre-charge or damaged accumulator - TEST NO. 1.</p> <p>Low water system pressure AND flow - TEST NO. 2.</p> <p>Low water system pressure (flow is OK) - TEST NO. 2.</p> <p>Low water system flow (pressure is OK) - TEST NO. 2.</p> <p>Improper water valve lift - TEST NO. 3.</p> <p>Worn or damaged water valve - TEST NO. 2.</p>	<p>Charge accumulator with dry Nitrogen. Rebuild or replace accumulator if necessary.</p> <p>Rebuild pump.</p> <p>NOTE: When testing, make sure cam is not holding water valve open - rotate gear so cam is off of valve lifter.</p> <p>If water is exiting relief valve outlet hose, replace relief valve. DO NOT attempt to adjust.</p> <p>Rebuild water valve.</p> <p>Check engine speed and correct if necessary.</p> <p>Rebuild pump.</p> <p>Perform valve lift adjustment. Repair valve or replace cam if necessary.</p> <p>Rebuild water valve.</p>
Water in gear case (milky or brown color in oil)	Worn or damaged water valve low pressure water seal and oil seal.	Rebuild water valve.
Oil leaking from below gear case shim area.	Worn or damaged water valve oil seal.	Rebuild water valve.
Water in pump crankcase (milky or brown color in oil)	Worn or damaged water pump low pressure seal or cracked ceramic plunger.	Rebuild pump head and plunger sleeves.
Engine dies when water system is engaged.	<p>Low engine RPM.</p> <p>Relief pressure too high - TEST NO. 2.</p> <p>Low engine power.</p> <p>Jammed or siezed pump or gear-case.</p>	<p>Throttle must be in FAST position. Adjust carburetor fast setting to 3450 to 3550 RPM - no load.</p> <p>Replace relief valve. DO NOT attempt to adjust.</p> <p>Check for contaminated fuel, plugged fuel filter or fuel line, plugged air cleaner, bad spark plug. (see Chapter 3 - Engine).</p> <p>Inspect components and repair as necessary.</p>

# Testing

## Before Performing Water System Tests

1. The water aeration system operates under very high pressures and severe duty cycles. Performance of the water system will be gradually reduced over a period of time due to normal wear in the pump, valve and accumulator. If you perform water system tests to isolate a possible problem, such as reduced hole depth, it is recommended that ALL tests be performed in the order listed even if the apparent problem has been isolated, such as low accumulator pre-charge pressure. This will verify that all components are operating properly.



### WARNING

**High pressure water system components can cause personal injury if disassembled incorrectly. Discharge water pressure at bleed valve before attempting any water system servicing. Open bleed valve slowly and avoid contact with high velocity water stream.**

2. With engine OFF, open high pressure bleed valve, and inspect aeration nozzles. Check for plugged nozzles. Verify size and quantity (see Nozzle Service and Replacement). Nozzles that are too large will cause loss in pressure and could cause damage to the accumulator and other water system components.

NOTE: You can check for plugged nozzles by aerating over a piece of cardboard, then inspecting cardboard.

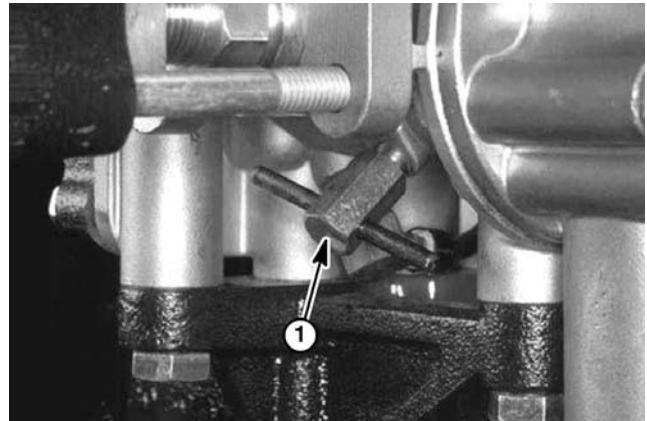

Figure 13

1. High pressure bleed valve

## TEST NO. 1: Accumulator Pre-Charge Pressure (Fig. 14, 15, 16, 17)

Pre-charge pressure is measured and corrected when the piston is resting on bottom cap of accumulator (high pressure bleed valve open). By temporarily installing Charging Tool (TOR4001) to top of accumulator, Nitrogen pressure can be measured and if required, more Nitrogen can be added.

Obtain a 3000 - 3500 PSI or 6000 PSI Nitrogen tank from a local compressed gas or welding supply shop. The charging tool is equipped with a Compressed Gas Association No. 677 tank connection. These tanks contain enough Nitrogen for 20-30 fills.

NOTE: During operation, working pressure of Nitrogen in accumulator will be equal to the operating pressure of the water system.

1. Park machine on a level surface, stop the engine, engage the parking brake, open the hood and disconnect the engine spark plug wires.



### DANGER

Charged accumulators contain high pressure nitrogen. Nitrogen is the only gas to use for accumulator charging. Installing **IMPROPER** gases in an accumulator can cause an **EXPLOSION AND DEATH**. Charging requires special tools and precautions. Charge accumulators in a well ventilated area. It is recommended that the accumulator be checked and charged by an Authorized TORO Distributor.

Wear eye protection. Keep hands and face away from gas valve.

Slowly open high pressure water bleed valve before servicing any component connected to high pressure water system. Opening the high pressure bleed valve allows any trapped water to escape from the system and also allows accumulator piston to move to bottom of accumulator cylinder. Failure to open bleed valve before servicing high pressure water components can cause personal injury, **DISMEMBERMENT OR DEATH**.

Charged accumulators cannot be shipped via air freight.

2. Slowly open the high pressure bleed valve allowing any pressurized water to escape.

3. Remove protective cover and yellow valve cap from top side of accumulator.

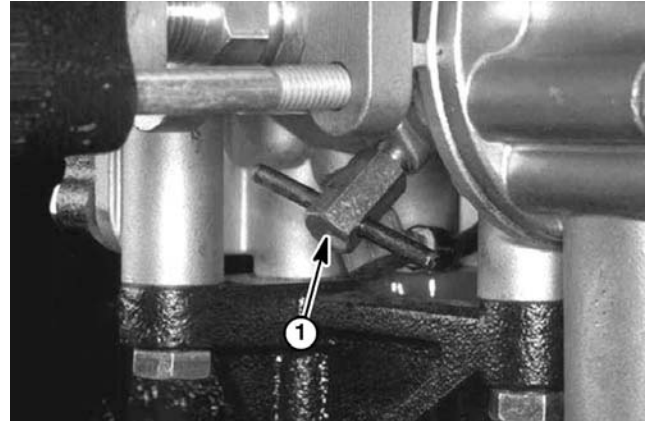

Figure 14

1. High pressure bleed valve

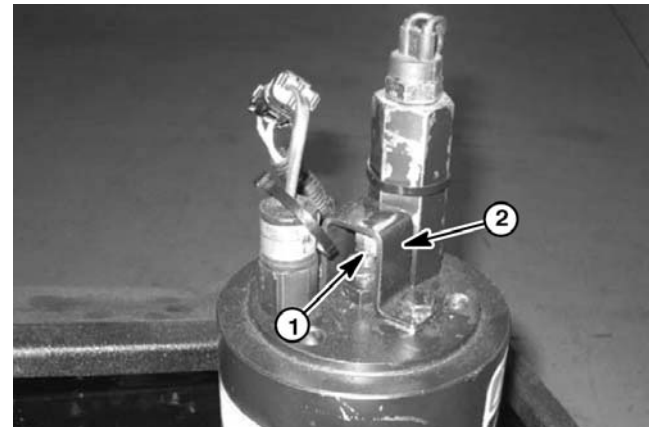

Figure 15

1. Protective cover

2. Valve cap

4. Attach and gently tighten special fitting of Charging Tool (TOR4001) to inlet on top of accumulator.

5. Close outlet valve on right hand side of charging tool to prevent loss of pressurized Nitrogen from accumulator. Close inlet valve on left hand side of charging tool to prevent back flow through the tank tube.

6. Rotate the jam nut (not the fitting) of the accumulator valve two (2) turns counterclockwise as viewed from the top. This opens the valve and pressurizes the tool and gauge.

Service range of Nitrogen pre-charge pressure:  
1800 to 2800 PSI. Allow +200 PSI if accumulator body is warm.

7. If pre-charge pressure is WITHIN service range, go to step 8. If pre-charge pressure is ABOVE service range, accumulator has internal damage and should be rebuilt or replaced. If pre-charge pressure is BELOW service range, go to step 10 under Adding Dry Nitrogen to Accumulator.

8. Tighten nut of accumulator valve clockwise and depressurize tool by slowly opening outlet valve on right hand side of pressure gauge.

9. Disconnect charging tool from accumulator. Reinstall the yellow protective cap and valve protector bracket.

### **Adding Dry Nitrogen to Accumulator**

10. With charging tool connected to accumulator, attach a charged tank of dry Nitrogen to high pressure tube on charging tool. Tighten tank fitting by turning hose fitting counterclockwise.

11. The accumulator tool, attached to the accumulator, has a pressurized manifold. Open inlet valve on left hand side of charging tool to pressurize supply tube. While watching pressure gauge on tool, slowly open supply tank valve. Pressure reading on gauge will start to rise. Close supply tank valve when gauge pressure reaches 2500 PSI. Wait a few minutes to make sure system pressure has equalized then add additional Nitrogen if necessary for 2500 PSI pre-charge.

12. Close accumulator valve by turning lower nut clockwise.

13. Slowly open knob on right hand side of charging tool de-pressurize the tool, then remove tool from accumulator. Reinstall yellow protective cap and valve protector bracket.

NOTE: After completion, install a tag on accumulator identifying the charging pressure and charging date.

14. Do Test No. 2: Water Pump Pressure and Flow.

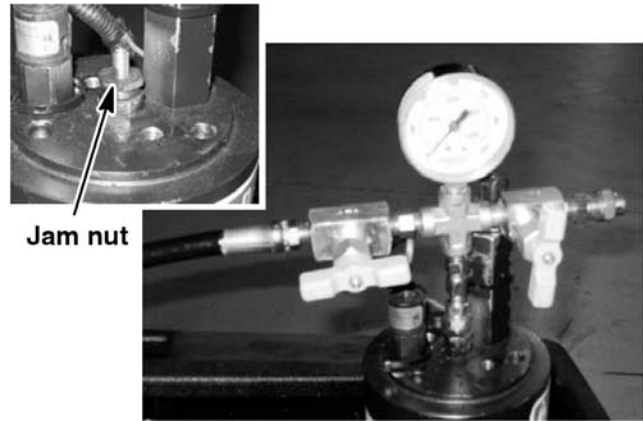

Figure 16



Figure 17

## TEST NO. 2: Water System Pressure and Flow (Fig. 18, 19, 20, 21, 22, 23)

1. The engine must be in good operating condition. Use a tachometer to verify that the engine is operating at specified full governed RPM (3450 to 3550 RPM no load). Engine speed will affect accuracy of flow meter reading.

2. Stop the engine, engage the parking brake and open the hood.



### WARNING

High pressure water system components can cause personal injury if disassembled incorrectly. Discharge water pressure at bleed valve before attempting any water system servicing. Open bleed valve slowly and avoid contact with high velocity water stream.

3. Slowly open the high pressure bleed valve allowing any pressurized water to escape.

4. Install Water System Pressure Gauge (TOR4005) into port in water valve housing as shown.

5. Disconnect wire harness connection for water valve clutch to prevent the water valve from operating during the test.

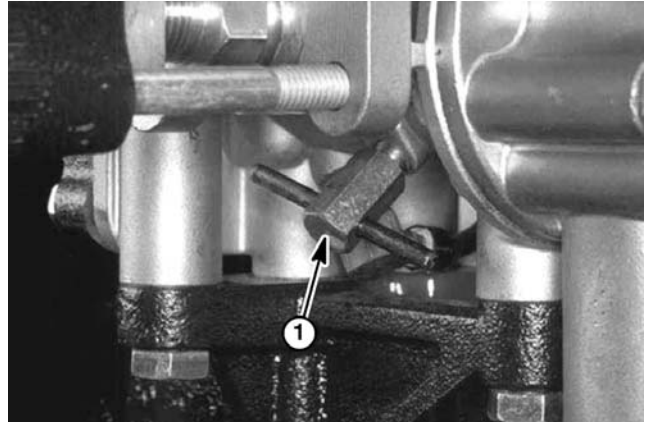

Figure 18

1. High pressure bleed valve

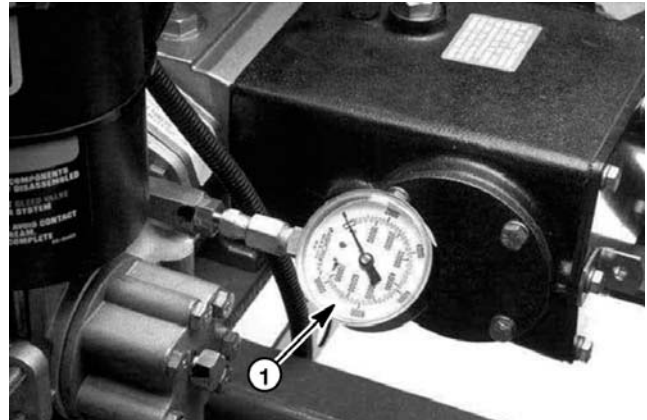

Figure 19

1. Water system pressure gauge (TOR4005)

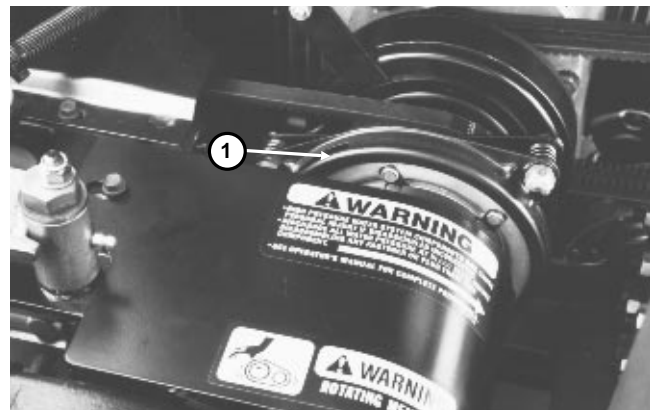

Figure 20

1. Water valve clutch

6. Install Flow Meter (TOR4006) between water supply hose and hose adapter. Connect hose adapter to quick connector on side of machine.

7. Turn on water supply. Open high pressure bleed valve until all air is out of the system. Close high pressure bleed valve for pump testing. NOTE: Air in system will cause improper test readings.

8. Disconnect hose from relief valve fitting.

9. THIS IS A TWO (2) PERSON OPERATION. Start engine and operate at full speed. WEAR SAFETY GLASSES! Have one person press and HOLD engage button while other person stands to side of machine and observes pressure gauge and flow meter readings.

PRESSURE should be  $5000 \pm 300$  PSI and FLOW more than 3.4 GPM.

If pressure is too high, replace relief valve.

If pressure AND flow is low, disconnect small tube running from bottom side of valve housing to water pump inlet by backing out small 1/16" NPT fitting (Fig. 39, Item 31). Plug open port with a 1/16" NPT plug. Do this test procedure again beginning with step 1. If pressure AND flow is still low, rebuild pump. After rebuilding pump, do this test procedure again beginning with step 1, to verify that valve is sealing properly in closed position. A large quantity of water exiting valve side of tube indicates a leaking valve ceramic sleeve or seal. Reconnect small tube.

If pressure is low, but flow is OK, make sure cam is not on roller follower, keeping valve in open position. If water is exiting outlet fitting on relief valve, replace relief valve. If water is not exiting outlet fitting on relief valve, rebuild water valve. After replacing relief valve or rebuilding water valve, do this test procedure again, beginning with step 1, to verify that pump has adequate flow at specified operating pressure.

If pressure is OK, but flow is low, rebuild pump.

10. Perform Test No. 3: Water Valve Lift.

11. Do steps 2 - 4 and 6 - 8 of this pressure and flow test again, with valve clutch connected to wire harness.

Pressure gauge needle will go rapidly to the relief setting ( $5000 \pm 300$  PSI) for 3 to 4 seconds, then begin to fluctuate rapidly when the unit begins aerating. Note the highest pressure. If highest pressure is 4000 to 4500 PSI, plan to rebuild the valve. If pressure is less than 4000 PSI, rebuild the valve.

12. After testing is completed, open high pressure bleed valve, then remove water system pressure gauge. Reinstall plug in open port of water valve housing. Connect relief valve hose. Remove flow meter.



Figure 21

1. Water supply quick connector



Figure 22

1. Flow meter/pressure gauge (TOR4006)

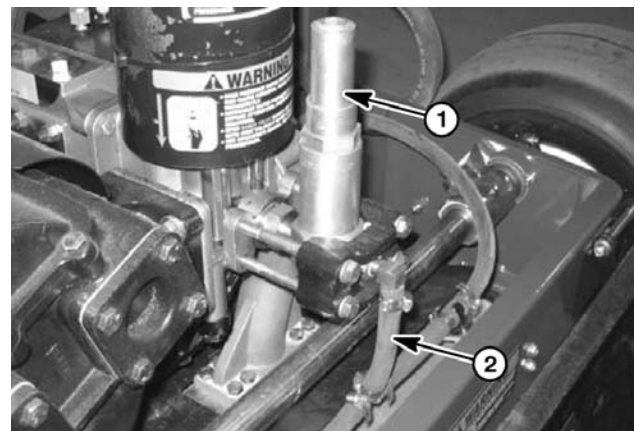



Figure 23

1. Relief valve

2. Hose

	<b>WARNING</b>
<p>Do not attempt to adjust or disassemble the relief valve. If the relief valve is not working properly, it must be replaced. If adjustment, disassembly or repair of the relief valve is attempted it could result in machine damage, personal injury, DISMEMBERMENT OR DEATH.</p>	

## TEST NO. 3: Water Valve Lift (Fig. 24, 25)

If valve lift is too high the valve may not seat correctly. If valve lift is too small, the pulses may not release enough pressurized water and the relief valve will open (wasting energy). Improper valve lift can also result in high contact stresses and rapid cam wear.



### WARNING

High pressure water system components can cause personal injury if disassembled incorrectly. Discharge water pressure at bleed valve before attempting any water system servicing. Open bleed valve slowly and avoid contact with high velocity water stream.

1. Park machine on a level surface, stop the engine, engage the parking brake, open the hood and disconnect the engine spark plug wires.
2. Slowly open the high pressure bleed valve allowing any pressurized water to escape.
3. Remove belt guard to expose the drive shaft.
4. Remove test cap from the feeder manifold and install Valve Lift Indicator (TOR4007) into this opening. Make sure dial indicator contacts top of water valve, then zero out dial indicator.
5. Make sure cam lobe is not contacting follower by rotating coupling assembly several turns and observing dial indicator.
6. Rotate coupling, moving cam lobe past cam follower and observe maximum reading on dial indicator.

Dial indicator should move 0.090 to 0.102. There should be no movement of dial indicator gauge on lead-in or lead-out portion of cam.

7. If indicator moves more than 0.102, cam lobe is probably contacting follower on lead-in portion of cam and must be adjusted (see Valve Lift Adjustment). If indicator moves less than 0.090, remove gear case cover and inspect cam for wear. Use your hand to rotate coupling to position working cam on top. Visually inspect top of cam lobe for wear. There is a thin area on this replaceable cam that does not contact the cam follower. If cam is worn, a ridge will develop between tip of cam and unused surface. If the ridge is deep enough to catch a fingernail, replace the cam (see Gear Case Service). If cam is not worn, adjust valve lift.

8. Go to step 11 under TEST NO. 2 - Water System Pressure and Flow.

**IMPORTANT:** A reading of 0.090 to 0.102 does not guarantee a properly adjusted cam. When in doubt, inspect cam. A worn cam which has been adjusted to 0.090 to 0.102 will not perform properly. A worn cam can cause opening of valve on lead-in portion of cam in this range.

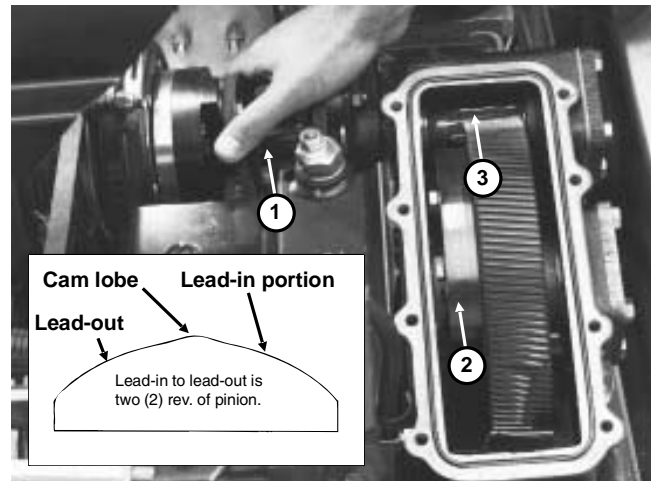

Figure 24

1. Coupling

2. Cam

3. Follower

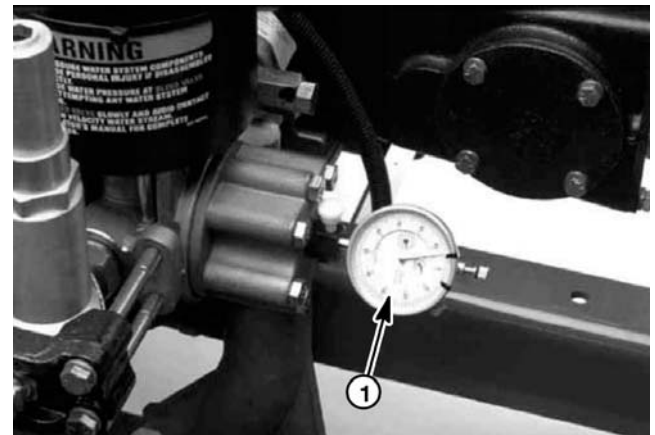

Figure 25

1. Valve lift indicator (TOR 4007)

# Adjustments

## Electric Brake Clutch Adjustment (Fig. 26)

1. Park machine on a level surface, stop the engine, engage the parking brake, open the hood and disconnect engine spark plug wires.

2. Adjust air gap to .018" by inserting a thickness gauge into the clutch openings. Evenly tighten the three lock nuts on clutch to reduce the air gap. Failure to maintain the correct air gap could result in clutch not engaging even though it is electrically energized.

NOTE: It may be necessary to remove clutch retainer to allow clutch rotation for access to all three (3) adjustment nuts.



Figure 26

1. Locknut (3)

## Water Valve Lift Adjustment (Fig. 27, 28, 29)

1. Park machine on a level surface, stop the engine, engage the parking brake, open the hood and disconnect the engine spark plug wires.



### WARNING

High pressure water system components can cause personal injury if disassembled incorrectly. Discharge water pressure at bleed valve before attempting any water system servicing. Open bleed valve slowly and avoid contact with high velocity water stream.

2. Slowly open high pressure bleed valve allowing any pressurized water to escape.

3. Remove belt guard to expose drive shaft. Remove gear case cover.

4. Use your hand to rotate coupling assembly, positioning working cam on top. Visually inspect top of cam lobe for wear. There is a thin area on this replaceable cam that does not contact the cam follower. If cam is worn, a ridge will develop between tip of cam and unused surface. If the ridge is deep enough to catch a fingernail, replace the cam lobe. Do not measure valve lift using a worn cam lobe. Rotate cam to make sure cam lobe is not contacting follower.

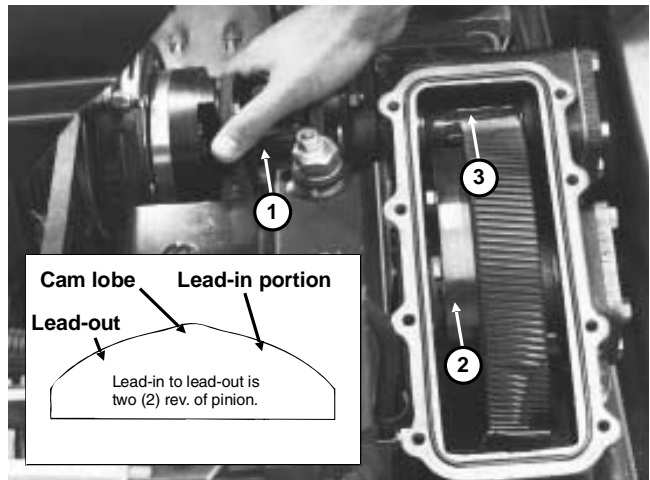

Figure 27

1. Coupling

2. Cam

3. Follower

5. Remove test cap from manifold feeder and install Valve Lift Indicator (TOR4007) into this opening. Make sure dial indicator contacts top of water valve, then zero out dial indicator.

6. Rotate coupling, moving cam toward cam follower. Continue to rotate until cam follower is on lead-in portion of cam, approximately one inch (slightly less than 1/2 turn of coupler) from cam lobe. If dial indicator shows no lifting of valve, loosen four (4) capscrews holding gear case to valve body. Remove one shim from both front and rear, then tighten capscrews. Repeat this procedure until some opening of valve occurs on lead-in portion to make sure cam follower touches cam.

7. Zero dial indicator again with cam follower completely off the cam. Rotate coupling, moving cam toward cam follower and continue to rotate until cam follower is on lead-in portion of cam, approximately one inch from cam lobe. Record amount of valve lift.

**IMPORTANT: Make sure shims on both front and rear side are the same thickness. Using different thicknesses can cause gear case damage.**

8. Add shims, equal to or greater by 0.002 inch, to amount measured. For example, if 0.015 is measured while follower is on lead-in portion of cam, add a 0.015 shim. If 0.009 is measured, add 0.010 shim (two 0.005 shims) and retighten capscrews.

NOTE: If more than a multiple of 0.005 shims are required, it is recommended that procedure be done in

two steps - for example if 0.023 is indicated, add 0.02 shim (four 0.005 shims) first, then repeat procedure.

**IMPORTANT: Clearances greater than 0.002 in. will cause high contact stresses and rapid cam wear.**

9. Check proper function of cam by again zeroing dial indicator with cam away from cam follower. Rotate coupling, moving cam toward cam follower and continue to rotate until cam follower is on lead-in portion of cam, approximately one inch from cam lobe. There should be no movement of dial indicator on lead-in portion of cam. Continue to rotate over cam lobe. Lift should measure  $0.10^{+0.002}/_{-0.004}$  in. (with new cam). Continue to rotate on lead-out portion. The dial indicator should read zero for entire lead-out portion.

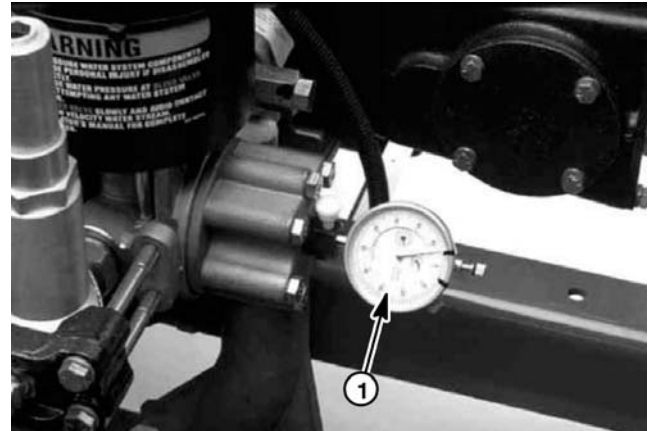

Figure 28

1. Valve lift indicator (TOR4007)

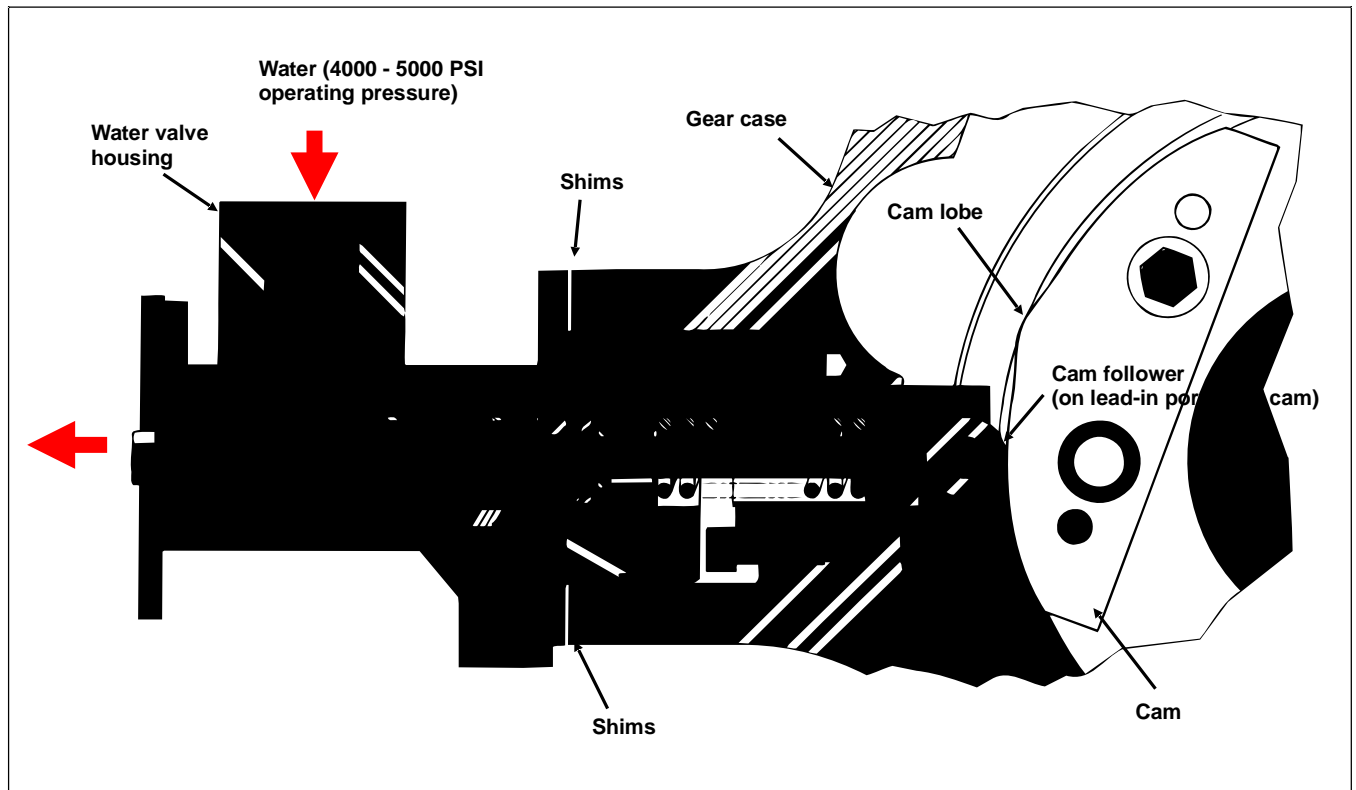

Figure 29

# Repairs

## Drive Coupling and Clutch Removal and Installation (Fig. 30)

1. Park the machine on a level surface, engage the parking brake, open the hood and disconnect the engine spark plug wires. Remove guard (Item 38).
2. To remove coupling shaft, remove four capscrews connecting the rubber couplers (Item 11, 12) to clutch (Item 8) and adapter hub (Item 16), then lift shaft away from machine.
3. Clutch (Item 8), pulley (Item 3) and clutch (Item 2) can now be removed by removing bolt (Item 26) and washer (Item 27). A puller tool may be required.
4. Apply "Never-Seez" or equivalent to engine shaft and pulley shafts. Make sure keys (Item 1 and 4) are properly installed, then align keyways in clutches and pulley with keys. Make sure clutch (Item 8) is installed so clutch angle (Item 7), clutch stops (Item 5, 33) and clutch bumpers (Item 6) will prevent clutch rotation. The clutch bumper gap should be  $0.22 \pm .03$  in.

5. Apply Loctite 271 or 680 to threads of bolt (item 26). Use special washer (Item 27) and install bolt. Remove engine air cleaner feed hose to access teeth of flywheel. Hold flywheel and tighten bolt to a torque of 25 – 30 ft-lb.

NOTE: A tapered hub (Item 16) is attached to cam gear-box input shaft. When installing hub, be sure to use special hardened washer (Item 18), apply Loctite 271 or 680 to threads of capscrew (Item 14) and tighten to a torque of 15 ft-lbs.

6. Install all bolts and spacers in drive coupling using illustration below. Position flat of spacer (Item 10) toward welded flange of drive shaft (Item 24). Tighten capscrews until shoulder of spacer is seated, then tighten to a torque of 15 ft-lb more than prevailing torque required to turn locknut on threads.

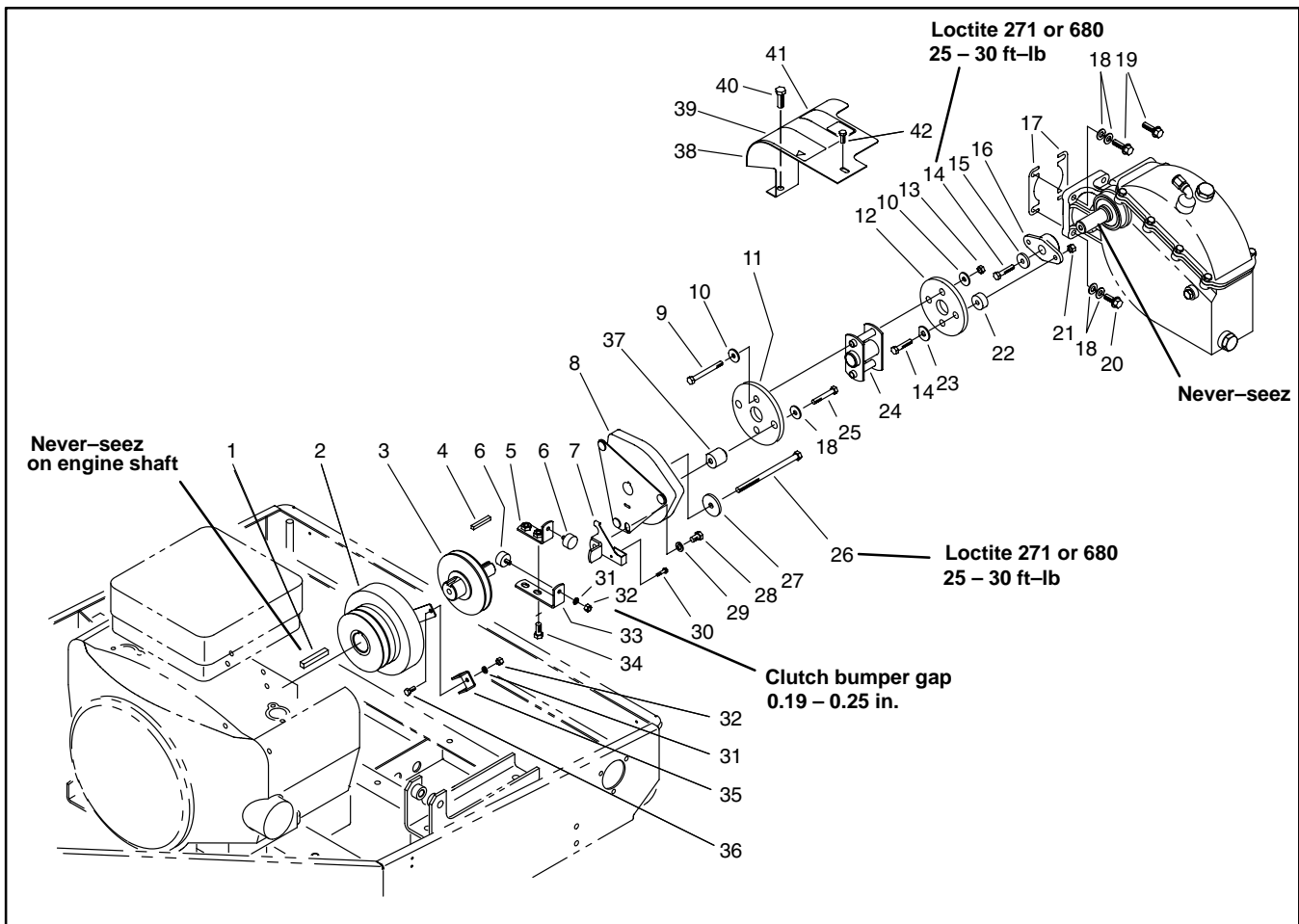

Figure 30

## Pump Drive Belt Replacement (Fig. 31, 32)

1. Park the machine on a level surface, engage the parking brake, open the hood and disconnect the engine spark plug wires.
2. Remove the drive coupling (see Drive Coupling Removal and Installation).
3. Disconnect electrical connectors for both clutches.
4. Remove clutch stops (Fig. 30, Item 5) and clutch retainer bracket (Fig. 30, Item 39).
5. Loosen hydraulic pump belt tension and remove small belt from hydraulic pump pulley (see Pump Drive Belt Adjustment in Chapter 4 - Hydraulic System).
6. Loosen water pump idler pulley and work belt off of large pulley. Carefully pull this belt out from under the electric clutches.
7. Reverse steps 2 - 6 to install the belt. Adjust hydraulic pump belt tension (see Pump Drive Belt Adjustment in Chapter 4 - Hydraulic System).

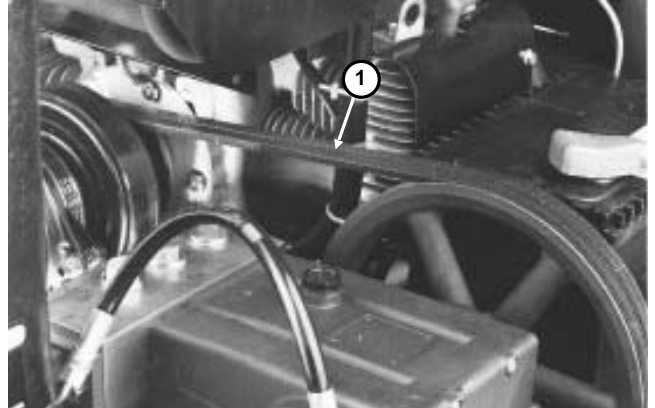

Figure 31

1. Water pump belt

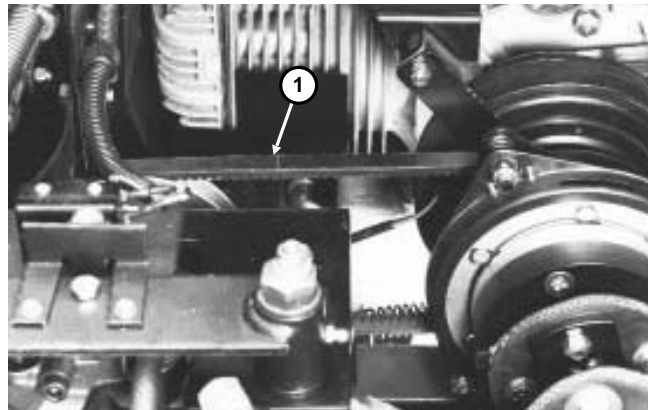

Figure 32

1. Hydraulic pump belt

## Water Filter Replacement (Fig. 33, 34)

When pump inlet pressure decreases or the water system shuts down, it usually means the water filter is restricted and must be replaced.

**IMPORTANT: Never operate the machine without a water filter. Operating without a water filter can cause severe damage to the water system.**

1. Put the machine on a level surface, engage the parking brake, stop the engine and disconnect the engine spark plug wires.
2. Locate the water filter assembly, which is mounted below the fuel tank.

**NOTE:** Be careful when removing filter body. Filter body is full of water and will be heavy.

3. Unscrew the filter body counterclockwise (as viewed from top). Remove filter and discard.
4. Rinse out filter body and insert a new filter.
5. Clean filter head to prevent contamination of water system. Thread body with filter onto filter head. Hand tighten.
6. Bleed water system with engine OFF and water supply connected and turned on:

A. Push button on top of filter head to purge air from filter body until water comes out around button.

B. Open high pressure bleed valve below accumulator to bleed air from water system. Close high pressure bleed valve.

**NOTE:** The quality and micron rating of this filter is very important. Do not use any substitutes. This filter has a 5 micron rating. For easier filter removal, use Filter Wrench (TOR4012).



Figure 33

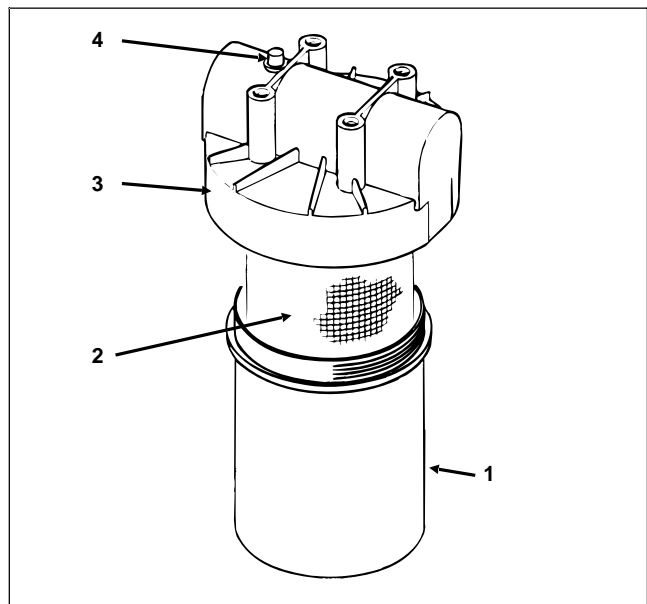

Figure 34

1. Filter body
2. Filter
3. Filter head
4. Bleed button



## Water Pump Head Service (Fig. 36)

The three major wear components in the high pressure pump that require maintenance include: the check valves, plunger sleeves, and plunger seals. These components will require maintenance after approx. 500 pump operating hours (approx 750 engine hours).



### WARNING

High pressure water system components can cause personal injury if disassembled incorrectly. Discharge water pressure at bleed valve before attempting any water system servicing. Open bleed valve slowly and avoid contact with high velocity water stream.

NOTE: Because of high torque requirements for check valve caps and difficulty of correctly installing check valves in horizontal position, it is recommended that the pump head be removed from the crankcase when servicing.

NOTE: Whenever a pump is removed from the machine for preventative maintenance or servicing, replace components in complete groups rather than individually. Complete servicing will increase the service interval between repairs.

### Pump Head Removal

1. Remove pump from machine (see Water Pump Removal and Installation).
2. Remove eight (8) nuts (Item 17). Carefully move pump head (Item 11) away from pump crankcase. Turn pump crankcase to help in removal of pump head.

### Check Valve Replacement (replace as a set)

1. Remove the six caps (Item 7) and pull out check valve assemblies.
2. Discard old check valves (Item 9) and remove any remaining seals (Item 10) stuck in the pump head.
3. Insert new seals (Item 10) and check valves (Item 9).
4. Install new seals (Item 8) in check valve caps. Apply Loctite 242 or equivalent to threads, install caps and tighten to a torque of 205 - 235 ft-lbs.

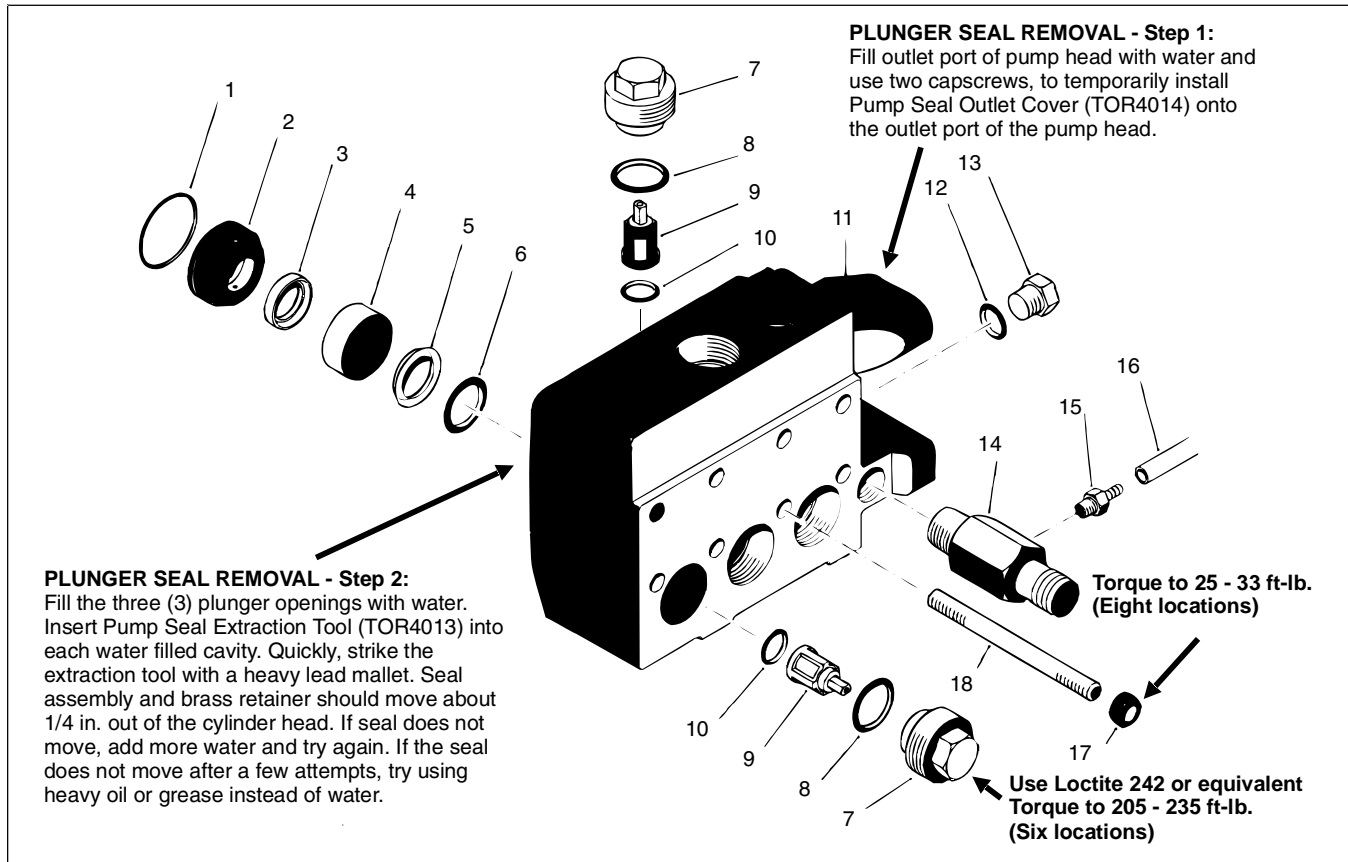

Figure 36

## Plunger Seal Replacement

(See illustration on previous page)

NOTE: Check valves must be in good condition for this procedure to work correctly.

1. Fill pump head outlet cavity with water, then use two capscrews to temporarily install Pump Seal Outlet Cover (TOR4014) onto outlet port of pump head. Check valves must be installed.

2. Position pump head on a SOLID workbench or in a vise keeping displacement rod openings pointing upwards.

3. Fill plunger openings with water. Insert Pump Seal Extraction Tool (TOR4013) into each water filled cavity. WEAR SAFETY GLASSES. Quickly, strike the extraction tool with a large hammer or mallet. The seal assembly and brass retainer should move about 1/4" out of the cylinder head. If seal does not move, add more water and try again. NOTE: If seal does not move after a few attempts, try using heavy oil or grease instead of water.

4. Remove all seals from pump head and remove outlet cover tool. Discard back-up ring (Item 6), packing vee (Item 5) and seal support (Item 4). Inspect brass seal retainer (Item 2) for wear and replace if worn. If brass seal retainer can be reused, remove and replace U-cup seal (Item 3) and O-ring seal (Item 1).

NOTE: Apply clean grease to each seal before installing in steps 5 – 9.

5. Insert back-up ring (Item 6), flat side first, into each pump head cavity.

6. Insert packing vee (Item 5) into Installation Guide (TOR4010) making sure that "V" will mate with back-up ring (Item 6).

7. Insert Installation Guide into cylinder head cavity and use Insertion Mandril (TOR4011) to completely install the seal.

8. Insert seal support (Item 4) into Installation Guide (TOR4010) making sure "V" groove will mate with high pressure seal. Insert Installation Guide into cylinder head cavity and use Insertion Mandril (TOR4011) to completely install seal support. This seal support fits tightly in the bore.

9. Install new U-cup seal (Item 3) and O-ring seal (Item 1) into seal retainer (Item 2). Install seal retainer into pump head cavity. Use a soft face (plastic) hammer or arbor press to completely insert backup ring into pump head.

## Plunger Sleeve Replacement (Model 09800)

(see Figure 38 on next page)

The plunger sleeves are installed on, and sealed to stainless steel plunger rods. This assembly is inserted through a special high pressure seal in the pump head. During pump servicing, a complete repair kit should be installed.

1. Remove plunger sleeves (Item 26) from crankcase plunger rods (Item 9) by loosening and removing plunger bolt assemblies (Item 30). The plunger sleeves can be gently pulled forward for inspection or replacement. Remove large washer (Item 25) from rear of plunger rod.

2. Remove O-Ring (Item 29) and PTFE seal (Item 28) on plunger bolt assembly (Item 30). Install new greased O-ring (Item 28) next to head on bolt, then install PTFE ring (Item 28).

3. Install new large washer (Item 25), then new plungers (Item 26), onto plunger rods.

4. Apply Loctite 271 or equivalent to threads of plunger bolts, then install assemblies onto plunger rods. Torque plunger bolts to 10 ft-lbs.

## Pump Head Installation (Fig. 37)

1. Apply grease to ceramic plunger sleeves. Carefully install pump head onto pump crankcase studs and plungers. While installing, tap evenly on pump head while turning pump crankshaft.

2. Install eight (8) nuts onto studs and evenly torque locknuts to 25 – 33 ft-lbs.

3. Install water pump assembly into frame (see Water Pump Removal and Installation).

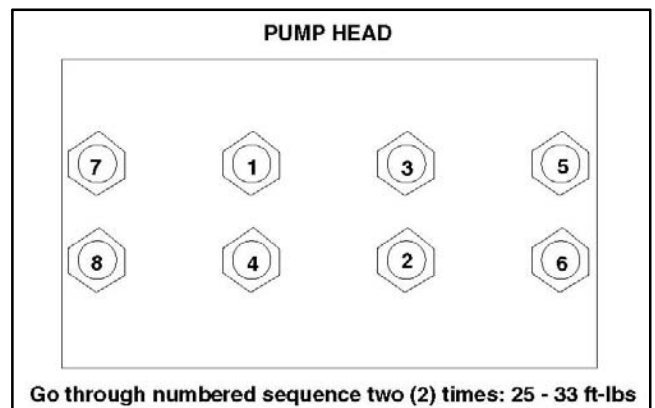

Figure 37

## Water Pump Crankcase Service (Fig. 38)

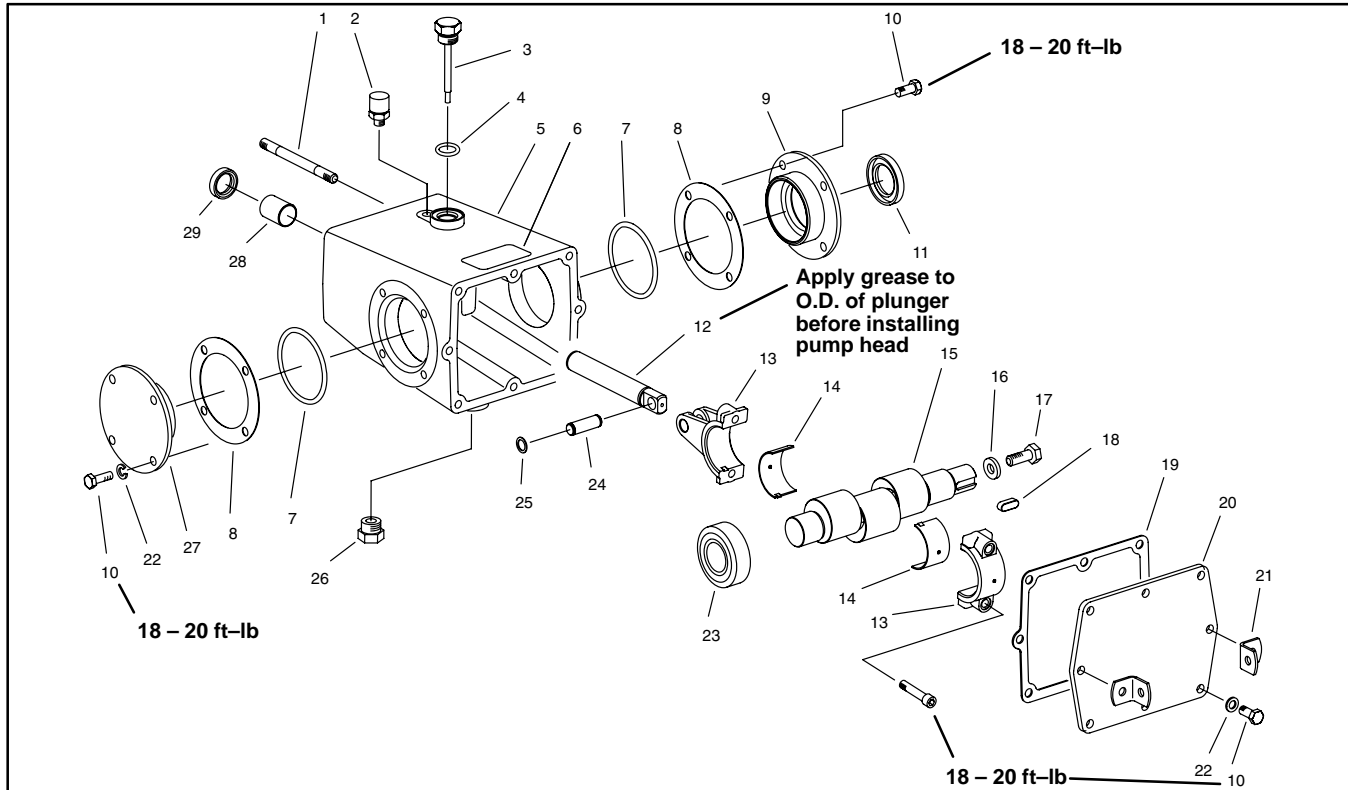

Figure 38

NOTE: Replace parts in complete sets.

1. Remove water pump from machine (see Water Pump Removal and Installation).
2. Remove pump head (see Pump Head Service).
3. Remove pulley from pump drive shaft using 1/4 in. bolts to separate tapered hub.
4. Remove rear cover (Item 20).
5. Remove connecting rod end caps (Item 13) and keep them in original order. Carefully push connecting rods (Item 12) forward.
6. Remove crank rod bearing caps (Item 9, 27), keeping shims (Item 8) in their original locations. Slide crank rod (Item 15) out of the crankcase. Inspect crank rod for galling or wear.
7. Pull connecting rods (Item 12) out through crankcase. Check for wear on plunger (12) and plunger guides (Item 28). If plunger guides are worn, use Wear Sleeve Tool (TOR4015) to drive guides out through crankcase. Also use this tool for plunger guide installation.

8. Inspect bearings (Item 23) for galling and pitting. If bearings are worn, replace bearings and bearing cups as a set.

9. Install new seal (Item 11) and O-rings (Item 7) and install crank rod, bearings and caps into crankcase.

10. Bearings should have a light pre-load, eliminating any end play. Add or remove end cap shims (Item 8) to change pre-load (see Crankshaft Bearing Installation and Shimming Page 6-26.2).

**Preload:** 0.005 – 0.007

**Capscrew torque:** 18-20 ft-lbs

11. Install end caps onto connecting rods and torque capscrews (Item 10) to 18 ft-lbs.

12. Install new gasket, crankcase cover, and torque crankcase cover capscrews (Item 10) to 18 ft-lb.

13. Install pulley with tapered hub onto pump drive shaft.

**Crankcase Bearing Installation and Shimming  
(Model 09801)**

1. Remove crankshaft bearing end caps.
2. Remove existing shims from both end caps.
3. Install one yellow (.020) shim and one pink (.015) shim onto input shaft bearing housing if required.
4. Install three yellow (.020), three blue (.005) and two red (.002) shims onto the end cap bearing housing.
5. Install input shaft end cap over crankshaft input shaft and secure to water pump housing. Tighten fasteners to a torque of 18 – 20 ft-lb.
6. Install end cap bearing housing over output shaft and secure with fasteners, but do not tighten.
7. Measure the crankshaft end play and remove shims from end cap as required to get  $.006 \pm .001$  INTERFERENCE FIT (see chart).
8. Tighten fasteners (Item 10) to a torque of 18 – 20 ft-lb.

Crankshaft end play from dial indicator	Shim thickness removed to get $.006 \pm .001$
.010	.016
.009	.015
.008	.014
.007	.014
.006	.012
.005	.012
.004	.010
.003	.009
.002	.008
.001	.007
.000	.006

This page is intentionally blank.

---

## Water Valve Service (Fig. 39, 40)

The water valve controls the release of high pressure water. The water valve is opened when a cam contacts and moves a roller follower. The follower moves the valve stem against spring pressure, which opens the water valve. After discharge, the valve spring closes the water valve, diverting pump flow into the accumulator for storage. The valve stem is installed completely through the water valve body and guided through a replaceable bushing and two sealing assemblies.

The water valve consists of a tapered valve stem sealing against a captured valve seat. The valve seat is sealed on both sides. One valve seat seal contacts the water valve body and the other seal contacts the manifold feeder. When the manifold feeder is installed on the water valve, the seals are compressed, locking in and maintaining correct alignment of the water valve and also preventing blow by.

Any abrasives in the water will rapidly erode the valve surfaces. The valve and valve seat can be ground and lapped to renew their working surfaces. After grinding, adjust the valve lift by measuring the lift and adjusting the shim stack thickness. The shim stack is located between the water valve body and gear case flange.

If the high pressure seal leaks for extended periods of time, water may be forced past the oil seal and into the gearbox. If the gearbox oil looks milky or brown, flush the system immediately, replacing oil, filter, and fluids in hydrostatic transmission and wheel motor.

The water valve assembly is similar to the pump head. It uses the same ceramic sleeve and seals. Since the water valve is the junction point for all high pressure liquid movement and is fairly difficult to access, complete rebuilding is recommended when this assembly is removed.

### Seal Replacement

There are two major seals in the water valve that will require regular maintenance or replacement. One seal keeps high pressure water in the high pressure water system and the other seal keeps the gear case oil within the gear case.

The high pressure water seal is identical to the pump head displacement rod seal. The major difference is the different brass insert.

If the oil seal leaks, oil will leak down and through the gear case shims. If low pressure water seal fails water will leak out between shims. If low pressure water seal and oil seal fail water will leak into the gear case.

### Water Valve Disassembly

1. Park machine on a level surface, stop the engine, engage the parking brake, open the hood and disconnect the engine spark plug wires.

**WARNING: High pressure water system components can cause personal injury if disassembled incorrectly. Discharge water pressure at bleed valve before attempting any water system servicing. Open bleed valve slowly and avoid contact with high velocity water stream.**

2. Open High Pressure bleed valve. Remove accumulator (see Accumulator Replacement). Remove manifold, manifold feeder and manifold support as an assembly from water valve body.

3. Disconnect drive coupler from gear case hub adapter (see Drive Coupling and Clutch Removal and Installation).

4. Drain oil from gearcase. Disconnect hydraulic lines from gearcase. Remove four (4) capscrews securing gear case to water valve and carefully pull gear case off of gear box pilot on water valve.

5. Disconnect valve seal drain tube by unscrewing small fitting at pump inlet. Remove two (2) locknuts from studs securing water valve to frame. Remove four (4) capscrews connecting water valve to water pump head. Remove water valve and put it on a clean work bench.

6. Install valve spring tool studs through the Valve Spring Compressor (TOR4008) and into threaded holes of water valve.

7. Tighten nuts to compress tool until retaining ring (Item14) can be removed from valve spool. Remove retaining ring, then carefully loosen nuts on special tool releasing valve spring compression.

8. Remove spring retainer (Item 15) and spring (Item16) from water valve stem. Remove screws (Item13) from gear case pilot. Remove gear case pilot (Item18) from water valve.

9. Use a wrench to keep spool valve (Item1) stationary and use a deep wall socket to loosen jam nut (Item 22) on valve spool.

10. Remove jam nut (Item 22) and large washer (Item 23), then gently push valve spool through valve body. Valve seat (Item 2) will come out with the valve.

11. Inspect sealing surfaces of valve spool and valve seat. If surfaces appear worn, replace or regrind. Both angles are 30 degrees.

12. Remove and inspect sleeve (Item 7) and remove backup (Item 6) and O-ring seals (Item 5).

13. Remove seal assembly (Items 25–30) by pressing a socket wrench through the casting. Discard all seal components.

14. Remove snap ring (Item 21) from gear box pilot (Item 18). Insert a shaft into the outboard side of the gear box pilot to push out sleeve bushing (Item 17), seal back-up (Item 20) and oil seal (Item 19).

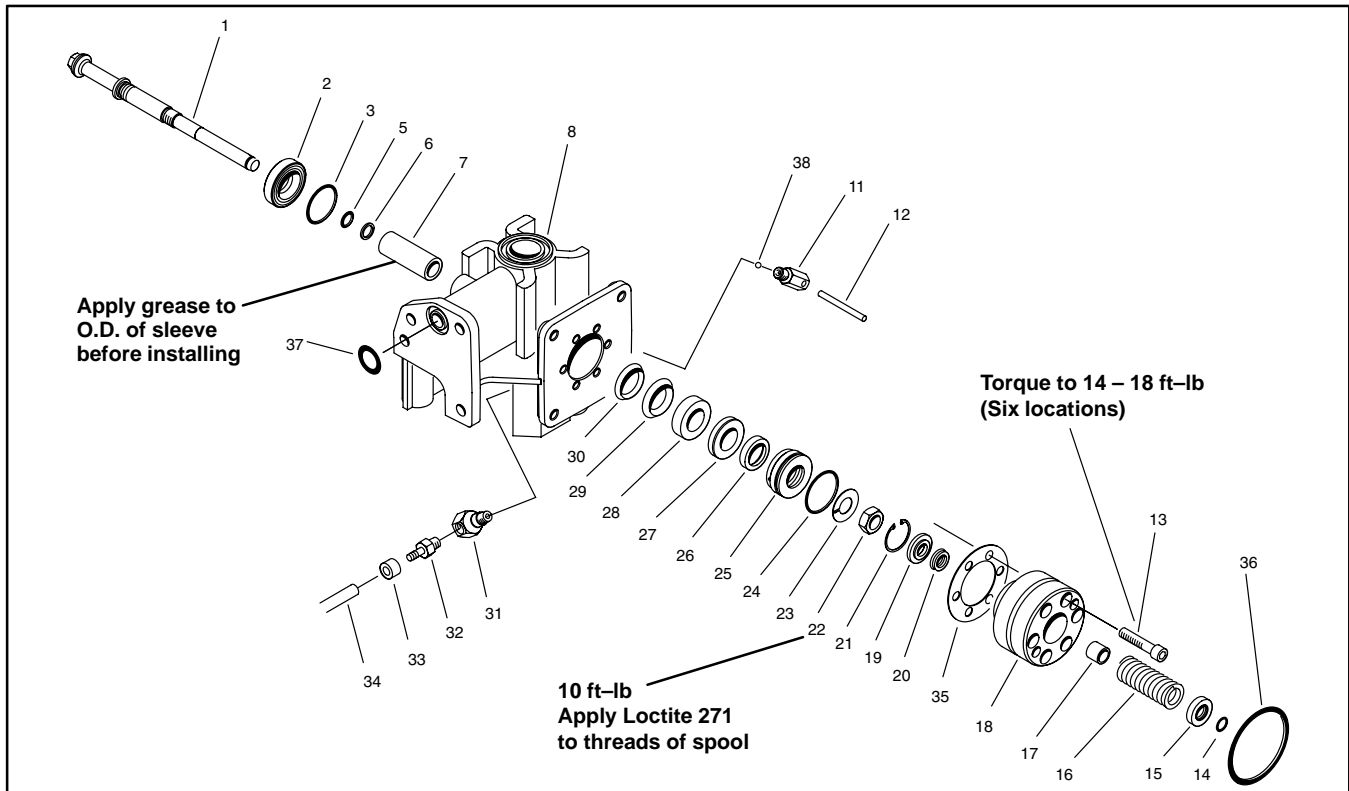

Figure 39

### Water Valve Assembly

1. Press a new sleeve bushing (Item 17) into gear case pilot until bushing is flush with recessed (oil side) surface.

2. Use a shaft to install oil seal (Item 19) and seal back-up (Item 20) into gear box pilot. Install retaining ring (Item 21).

3. Grease O-ring (Item 5) and back-up ring (Item 6), then install onto valve spool (Item 1). Rubber O-ring is furthest away from threads.

4. Install black back-up ring (Item 30) into valve cavity, flat side first.

5. Use Valve Seal Installer (TOR4009) and Seal Insertion Mandrel (TOR4011) to properly install packing seal (Item 29) and seal/plunger support (Item 28) into valve body. Remove installers.

6. Insert valve guide (Item 27) into valve body. Install O-ring (Item 24) and U-cup seal (Item 26) to seal retainer (Item 25), then install into valve cavity.

7. Apply grease to outside of sleeve (Item 7). Use valve spool inserted through sleeve to gently drive sleeve into seals, inserting it from the "spring" side.

8. Insert valve spool (Item 1) through valve seat (Item 2) and install O-ring (Item 3) on inboard side of valve seat.

9. Hold spool and seat in place so O-ring does not fall out of place, then carefully slide valve spool, new sleeve seals, and valve seat, through ceramic sleeve.

10. Install flat washer (Item 23) onto valve spool. Apply Loctite 271 or equivalent to threads and install jam nut (Item 22). Tighten to a torque 10 ft-lbs.

11. Fill snap ring groove in valve spool (Item 1) with wax to prevent damage to seal. Install gear case pilot (Item 18) making sure the drain hole is pointing down. Holes in pilot allow only one method of installation. Tighten screws (Item 13) to a torque of 14 – 18 ft-lb.

12. Install compression spring (Item 16) onto valve spool.

13. Install valve spring studs through Valve Spring Compressor (TOR4008) and into threaded holes of water valve. Put spring retainer (Item 15) over spring and under spring compressor. Tighten nuts to compress spring, and install retaining ring (Item 14). Remove special tool.

NOTE: The manifold feeder keeps the valve seat stationary. The spring force of the water valve positions the valve seat prior to Feeder Manifold installation. Make sure cam lobe does not contact cam follower during feeder manifold installation (Fig. 29).

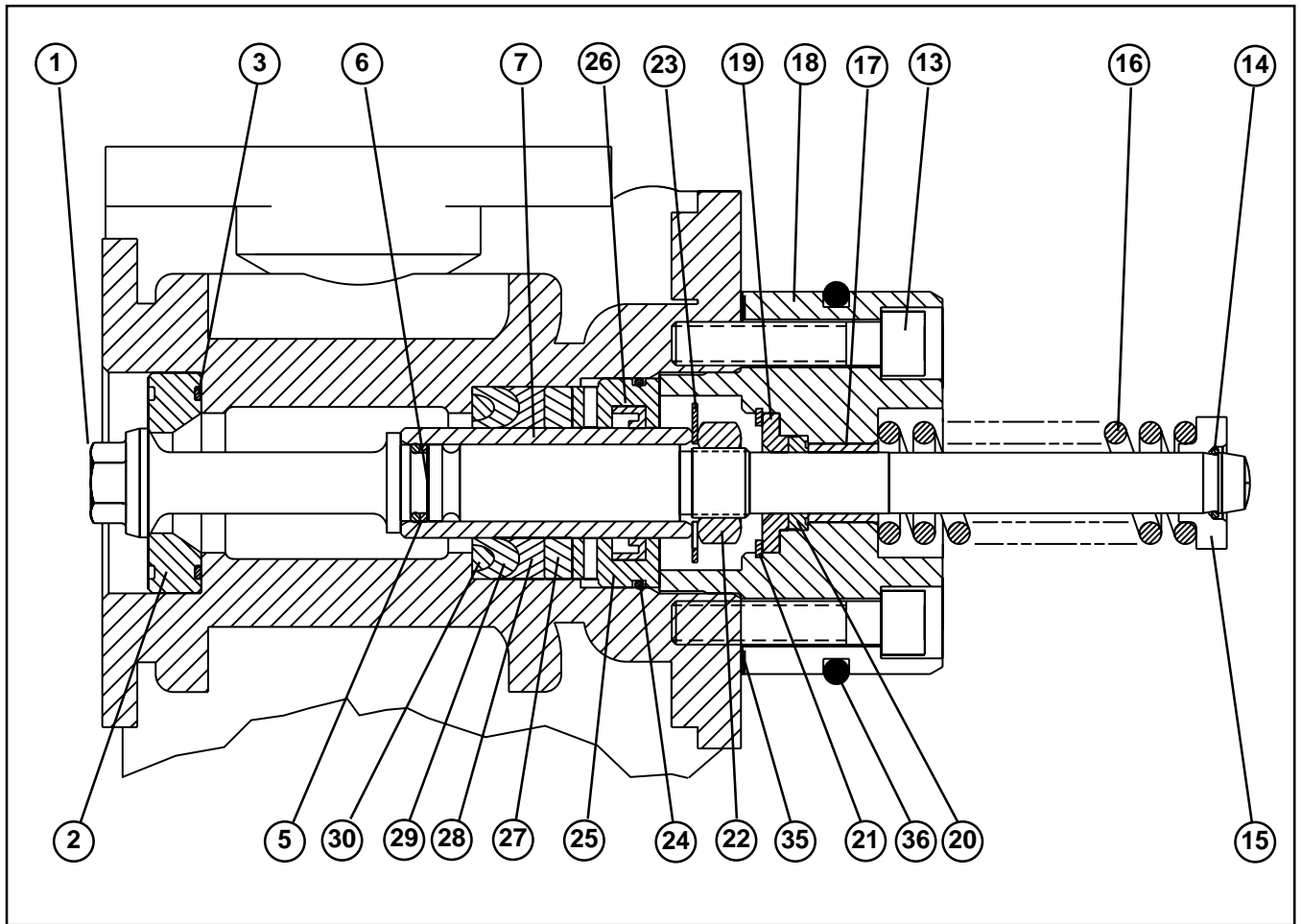

Figure 40



## Nozzle Service and Replacement

NOTE: See **Specifications** section of this chapter for more information.

1. Park machine on a level surface, stop the engine, engage the parking brake, open the hood and disconnect the spark plug wires from the engine.

2. Inspect nozzle configuration and diameter. Nozzles are stamped with numbers indicating the drill size of the orifice. Nozzle orifice can be inspected by inserting shank end of drill bit matching size stamped on orifice. If drill bit fit is loose, the nozzle is worn. If nozzles are worn or incorrect, replace with new nozzles in correct configuration.

3. The nozzle check valves and seats are located in the nozzle drops and are easily replaced if they wear. Occa-

sionally inspect the springs especially if one nozzle leaks water after the machine is shut down.

4. For normal operation, install nozzle springs with the narrow spiral pointing up and the check ball on top of the spring. To block the flow for different nozzle configurations, install the narrow spiral pointing down with the check ball below the spring.

NOTE: Nozzles are stamped with numbers indicating drill size of orifice. Standard configuration is 11 nozzles, which will produce depths of approximately 4 to 6 inches, depending on soil conditions. Blocked nozzle locations are obtained by reversing nozzle check valve and spring.

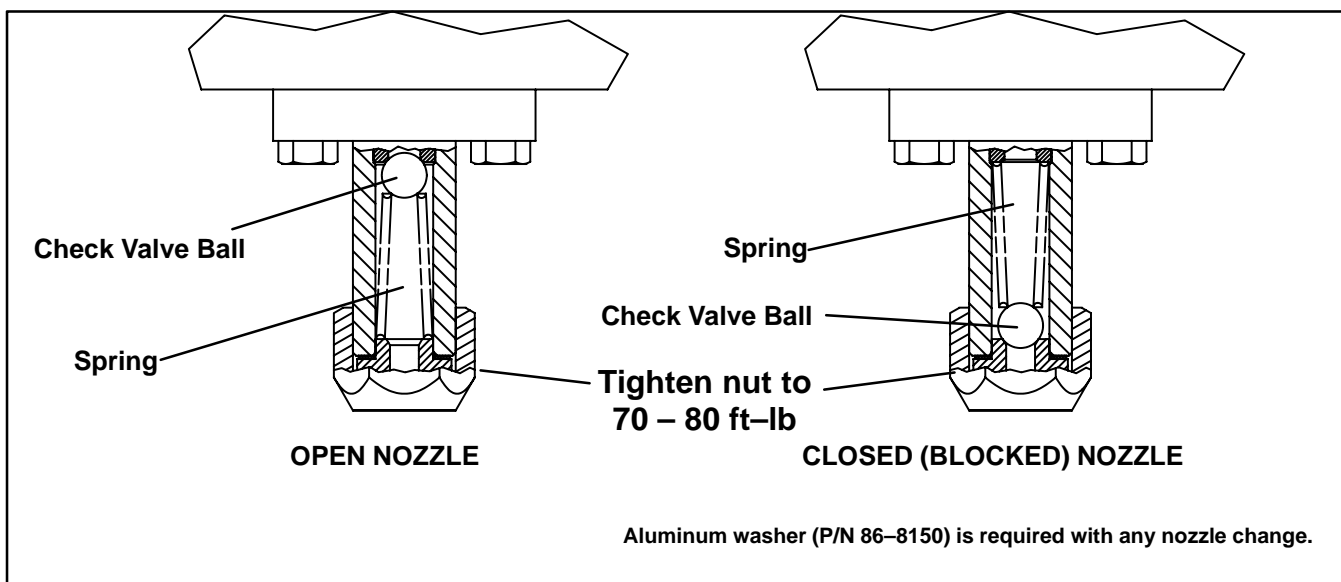

## Accumulator Replacement (Fig. 43)

1. Stop the engine, engage the parking brake, open the hood and disconnect the engine spark plug wires.



### **DANGER**

**Charged accumulators contain high pressure nitrogen. Nitrogen is the only gas to use for accumulator charging. Installing IMPROPER gases in an accumulator can cause an EXPLOSION AND DEATH. Charging requires special tools and precautions. Charge accumulators in a well ventilated area. It is recommended that the accumulator be checked and charged by an Authorized TORO Distributor.**

**Wear eye protection. Keep hands and face away from gas valve.**

**Slowly open high pressure water bleed valve before servicing any component connected to high pressure water system. Opening the high pressure bleed valve allows any trapped water to escape from the system and also allows accumulator piston to move to bottom of accumulator cylinder. Failure to open bleed valve before servicing high pressure water components can cause personal injury, DISMEMBERMENT OR DEATH.**

**Charged accumulators cannot be shipped via air freight.**

2. Slowly open the high pressure bleed valve allowing any pressurized water to escape

3. Remove splash shield from manifold to get access to capscrews securing accumulator. Use a socket wrench with long extension to remove four (4) capscrews (Item 14) securing accumulator (Item 47) to valve housing (Item 11). Remove the accumulator. Discard O-ring (Item 26).

4. Install new O-ring seal (Item 26) into groove on top of valve housing. Carefully install accumulator onto top of valve housing. Make sure decals (Items 47:2, 47:1) are facing forward and securely attached to accumulator.

6. Install four (4) NEW special bolts (Item 14) through valve body and into base of accumulator. Tighten to a torque of 40 ft-lb.

7. Charge accumulator with dry Nitrogen (see TEST NO. 3: Accumulator Pre-Charge Pressure and Adding Dry Nitrogen in the Testing section).

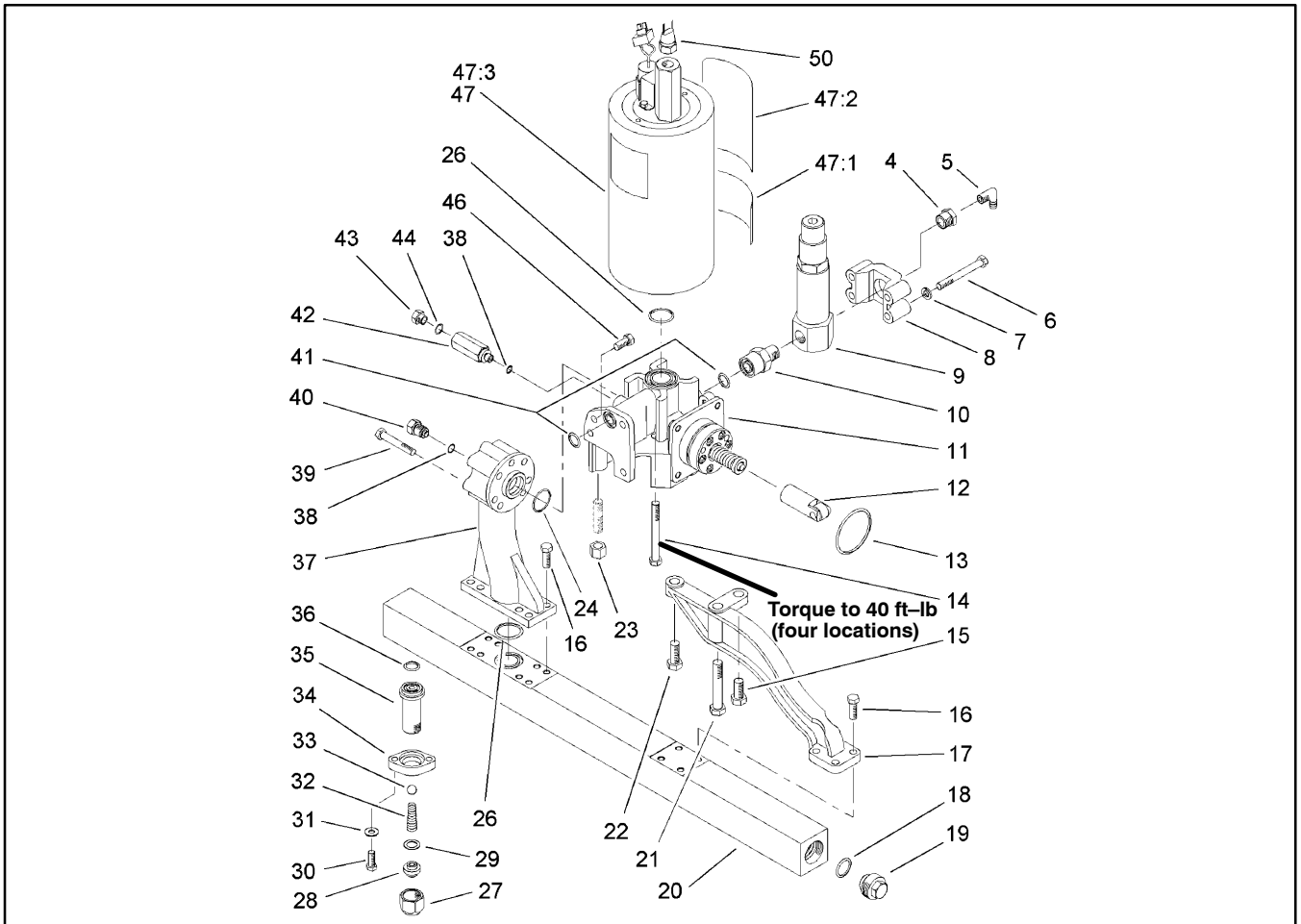

Figure 43

## Accumulator Service (Fig. 44, 45, 46)

The accumulator piston seals will wear over a period of time. As seals wear, the accumulator will require more frequent recharging and eventually, it will not hold gas.

1. Park machine on a level surface, stop the engine, engage the parking brake and open the hood.



### DANGER

**Charged accumulators contain high pressure nitrogen. Nitrogen is the only gas to use for accumulator charging. Installing IMPROPER gases in an accumulator can cause an EXPLOSION AND DEATH. Charging requires special tools and precautions. Charge accumulators in a well ventilated area. It is recommended that the accumulator be checked and charged by an Authorized TORO Distributor.**

**Wear eye protection. Keep hands and face away from gas valve.**

**Slowly open high pressure water bleed valve before servicing any component connected to high pressure water system. Opening the high pressure bleed valve allows any trapped water to escape from the system and also allows accumulator piston to move to bottom of accumulator cylinder. Failure to open bleed valve before servicing high pressure water components can cause personal injury, DISMEMBERMENT OR DEATH.**

**Charged accumulators cannot be shipped via air freight.**

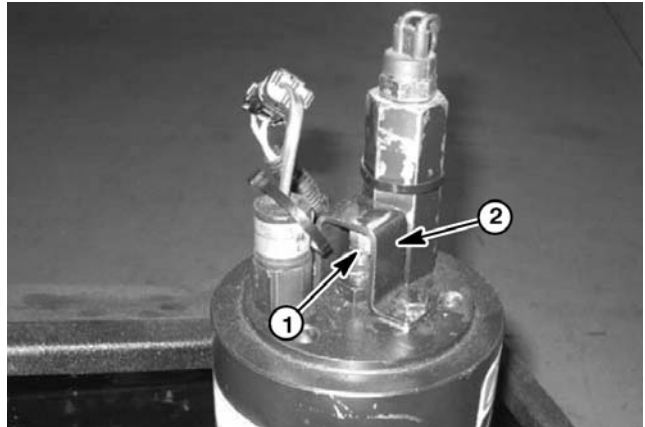
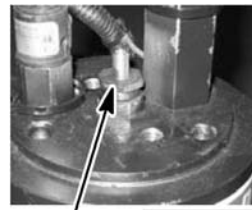

Figure 44

1. Protective cover

2. Valve cap (yellow)



Jam nut

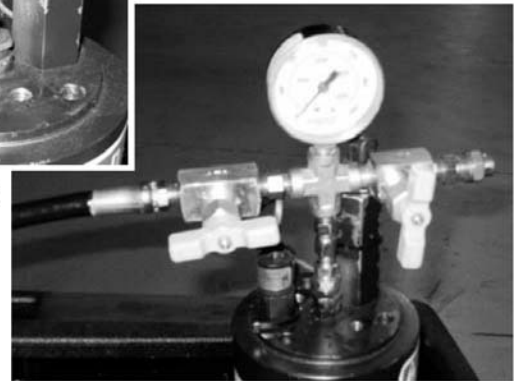

Figure 45

2. Slowly open the high pressure bleed valve allowing any pressurized water to escape.
3. Remove protective cover from top of accumulator.
4. Attach and gently tighten special fitting of Charging Tool (TOR4001) to inlet on top of accumulator.
5. Close both valves on charging tool to prevent loss of pressurized Nitrogen from accumulator.
6. Rotate the jam nut (not the fitting) of the accumulator valve two (2) turns counterclockwise as viewed from the top. This opens the valve and pressurizes the tool and gauge.
7. Slowly open outlet valve on right hand side of charging tool to release pressurized gas from accumulator. When gas stops escaping, disconnect the charging tool.

8. Remove gas valve (Item 4) from top of accumulator.

9. Remove accumulator from top of water valve housing (see Accumulator Replacement).

10. Insert Accumulator Cap Wrench (TOR4003) into the top cap (Item 12) of the accumulator. Hold the accumulator cylinder (Item 6) stationary using a strap or chain wrench and remove the top cap (Item 12) and bottom cap (Item 9) of the accumulator.

11. Use a brass or aluminum shaft to force the piston (Item 8) out of top side of accumulator and discard the piston.

### Accumulator Service Evaluation

Inspect bore of accumulator cylinder for score marks or wear. If barrel of accumulator is not scratched or scored, it can be reused. If bore is scored or damaged, it will require resurfacing and nickel plating. If cylinder bore is damaged, it may be more cost effective to replace the complete accumulator than to continue this repair.

### Accumulator Assembly and Seal Installation

12. If bore not damaged or worn, use solvent to thoroughly clean accumulator cylinder.

13. Apply clean hydraulic oil to new end seal and back-up ring (Item 4). Install end seal and back-up ring in groove of bottom end cap (Item 9) so O-ring is toward the piston. Apply "Never-Seez" or equivalent to threads of end cap. Carefully install end cap and tighten to a torque of 125 ft-lbs.

14. Special grease is supplied with a new piston. Apply coating of special grease to piston. Make sure spaces between seals on piston are filled with special grease. Put a light coating of special grease on accumulator bore and installation tool.

15. Use Accumulator Seal Installation tool (TOR4002) to prevent seal damage during piston installation. CAREFULLY insert this tool into top side of cylinder. SLOWLY insert piston (large cross facing down) through the tool and into the cylinder bore.

16. Move piston to bottom of accumulator cylinder. Add 11 oz. of Mobil DTE 26 hydraulic oil to completely fill cup in piston and cover top edges of piston.

17. Apply clean hydraulic oil to new end seal and back-up ring (Item 4). Install end seal and back-up ring in groove of top end cap (Item 12) so O-ring is toward the piston. Apply "Never-Seez" or equivalent to threads of end cap. Carefully install end cap and tighten to a torque of 125 ft-lbs.

18. Install gas valve (Item 3) using a new O-ring (Item 4).

19. Install accumulator onto water valve housing (see Accumulator Replacement).

20. Charge accumulator gas chamber with dry Nitrogen (see TEST NO. 1: Accumulator Pre-Charge Pressure Test / Adding Dry Nitrogen).

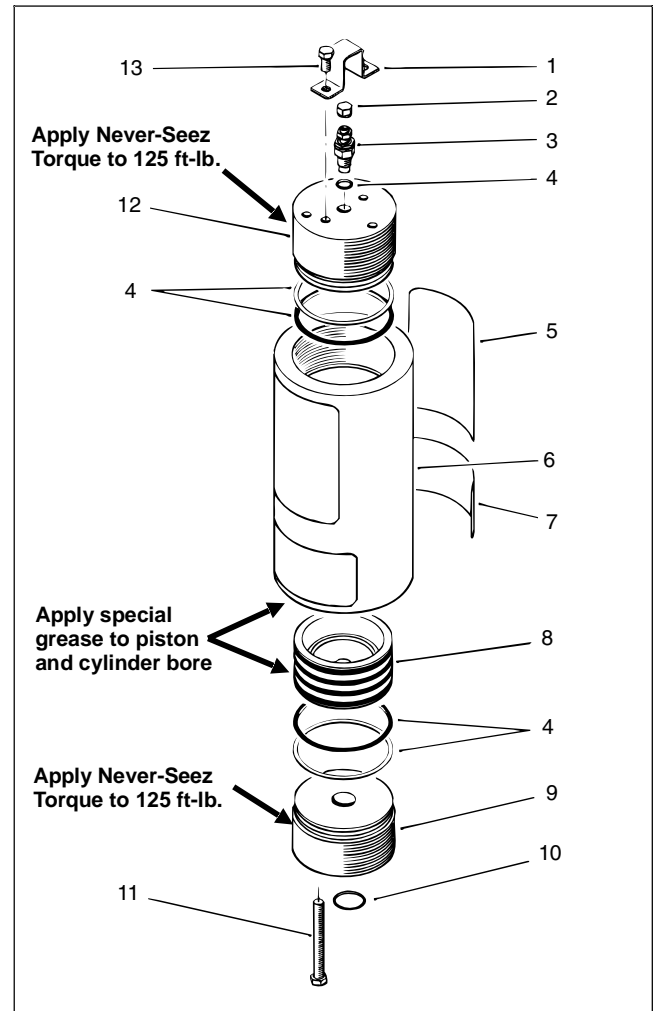

Figure 46

# General Information

---

## Storage

**It is very important that the water system be drained to avoid freezing and damaging the components. Drain system as follows:**

1. Stop engine, remove key from ignition switch and remove wires from spark plugs.
2. Remove (2) screws securing drive shield to frame and remove shield.
3. With the engine "OFF" and key removed from ignition, rotate the drive coupling by hand until resistance is felt. Continue to rotate the coupling about 1/4 revolution, opening the cycling valve.
4. Using the appropriate reducers (National Pipe thread), connect a source of compressed air (maximum pressure 150 psi – minimum pressure 90 psi) to the water inlets on either side of machine.

**DANGER: Compressed air can penetrate the skin and cause physical harm. Use extreme caution and wear protective goggles and gloves when working with high pressure air. Get prompt medical attention if an injury occurs.**

5. Let compressed air flow through the machine for 3 minutes. While compressed air is flowing, temporarily open the spray wash and high pressure drain valve, purging water from the spray wash and high pressure system.
6. Disconnect compressed air and reducers. Reinstall the drive shield previously removed and tighten the relief valve tube.
7. Remove and drain the water filter container. Install new filter and replace the filter container.

## Engine

1. Drain the engine oil from the oil pan and replace the drain cap.

2. Remove and discard the oil filter. Install a new filter.
3. Refill the engine with 3 qts. of recommended SAE 30 wt. motor oil.
4. Start the engine and run at idle speed for two minutes. **DO NOT RUN LONGER THAN TWO MINUTES.**
5. Stop the engine; remove the spark plugs.
6. Pour one ounce of clean engine oil into spark plug holes.
7. With the spark plugs removed, crank the engine with the starter for a least 12 revolutions to distribute oil in the cylinders.
8. Reinstall spark plugs.
9. Drain the gasoline from the fuel tank and fuel lines. Reinstall all lines and secure all connections.
10. Thoroughly clean and service the air cleaner.
11. Check the oil filler cap and fuel tank cap to ensure they securely in place.

## Traction Unit

1. Thoroughly clean machine.
2. Grease or oil all fittings or pivot points.
3. Check to make sure all tires are over inflated to 20 – 30 p.s.i.
4. Lightly sand and use touch up paint on all areas that are scratched, chipped or rusted.
5. Drain and replace hydraulic oil and filter on cam gear case.
6. Drain and replace oil in water pump case.
7. Clean the battery, terminals and posts with a wire brush and baking soda solution. Coat cable terminals and battery posts with skin over grease or petroleum jelly. Recharge battery.



# Wheels, Brakes and Steering

## Table of Contents

ADJUSTMENTS.....	2	REPAIRS .....	3
Brake Adjustment .....	2	Brake Service .....	3
		Wheel Bearing Service .....	4

# Adjustments

---

## Brake Adjustment (Fig. 1)

1. Park machine on a level surface and stop the engine.
2. Remove screws securing cover to under side of tiller handle. Remove cover.
3. Loosen upper jam nut securing brake cable to bracket.
4. Tighten lower jam nut until 25 to 30 pounds of force are required to actuate brake lever. Tighten jam nut.
5. Install lower cover.

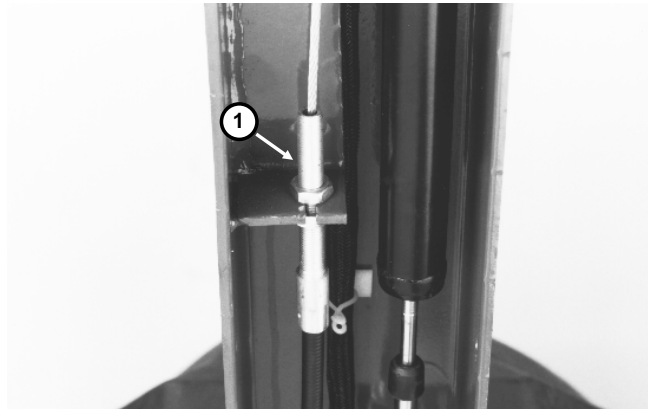

Figure 1

1. Brake cable

# Repairs

## Brake Service (Fig. 2)

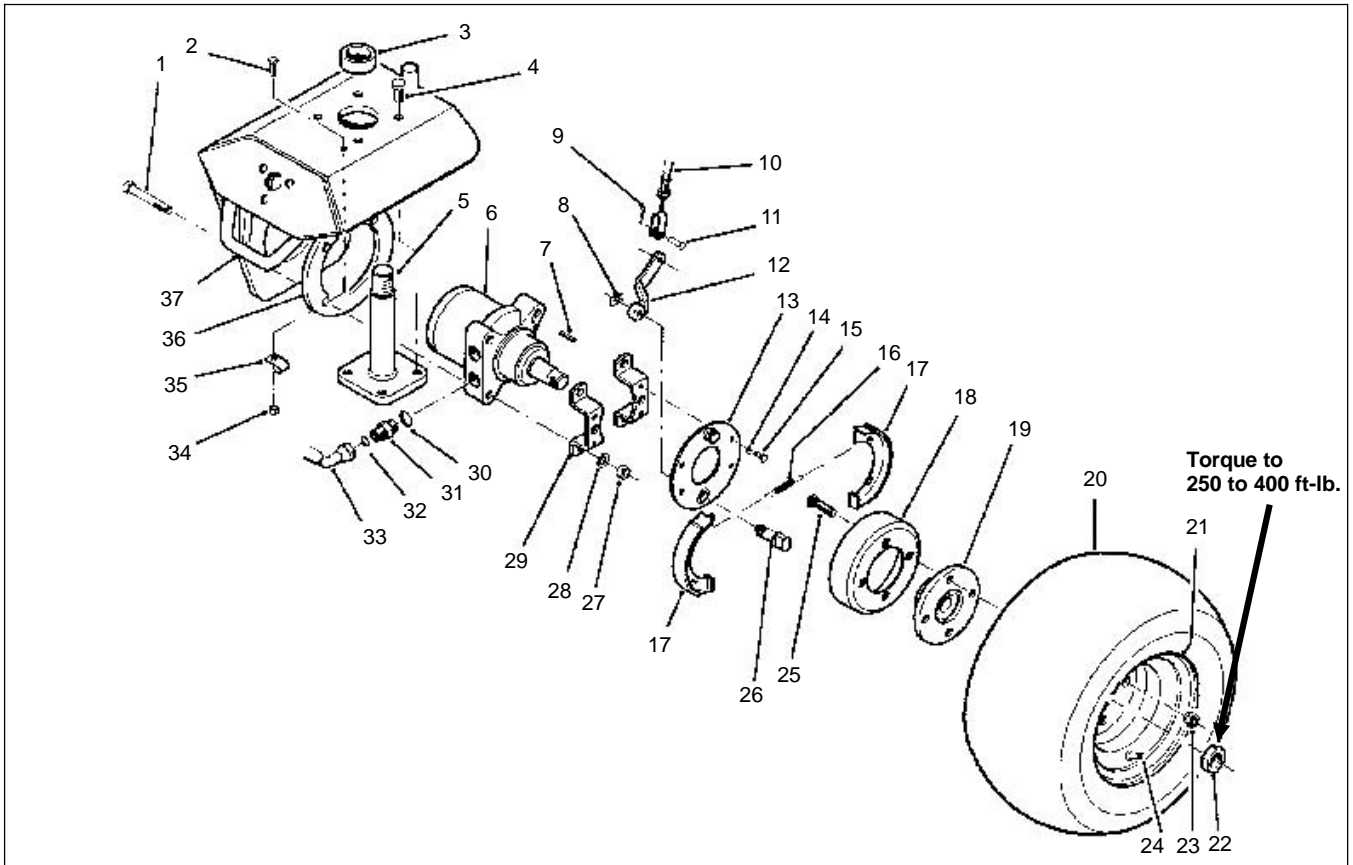

Figure 2

1. Park machine on a level surface, stop the engine and engage the parking brake. Open the hood and disconnect engine spark plug wires. Lift drive wheel off the ground using a jack. Block front and rear of other wheels.

2. Remove wheel nuts (Item 23) and remove wheel. Remove spindle nut (Item 22) from wheel hub.

3. Mount a wheel puller to wheel mount studs and remove wheel hub (Item 19) and brake drum (Item 18). Remove key (Item 7) from wheel motor shaft.

**IMPORTANT: To prevent damage to wheel motor, DO NOT hit wheel hub with a hammer during removal or installation.**

4. Remove brake shoe springs (Item 16) and brake shoes (Item 17).

5. Repair or replace parts as necessary.

6. After installing brake shoes, install brake shoe springs (Item 17) into holes on each brake shoe plate from the outside. Springs should be installed in opposite direction of each other.

7. Mount key (Item 7) in wheel motor shaft so top of key is in line with taper in shaft, then install wheel hub and brake drum.

8. Install spindle nut (item 13) and tighten to a torque of 250 - 400 ft-lb.

9. Install wheel and secure with wheel nuts. Tighten wheel nuts evenly in a crossing pattern to a torque of 40 to 50 ft-lb.

10. Adjust and check brakes.

## Wheel Bearing Service (Fig. 3)

1. Park machine on a level surface and raise wheels to aerate position. Engage parking brake, open hood and disconnect engine spark plug wires.

2. Remove dust cap (Item 28) from end of wheel spindle.

3. Remove cotter pin (Item 27), slotted nut (Item 29) and washer (Item 30). Slide wheel and hub off of spindle shaft.

4. Pull seal (Item 34) out of wheel hub (Item 23).

5. Remove bearings (Item 32) from both sides of wheel hub. Clean bearings in solvent. Make sure the bearings are in good operating condition. Clean inside of wheel hub. Check bearing cups (Item 33) for wear, pitting or other noticeable damage. Replace worn or damaged parts.

6. If bearing cups were removed from wheel hub, press them into hub until they seat against the shoulder.

7. Pack both bearings with grease. Use No. 2 general purpose lithium base grease containing E.P. additive. Install one bearing into cup on inboard side of wheel hub. Lubricate inside of new lip seal and press it into wheel hub.

**IMPORTANT: The lip seal (Item 34) must be pressed in so it is flush with end of hub. Lip of seal must be toward the bearing.**

8. Pack inside of wheel hub with some grease (not full). Install remaining bearing into bearing cup.

9. Slide hub onto spindle shaft and secure it in place with flat washer and slotted nut. DO NOT tighten nut or install cotter pin.

10. Adjust pre-load on wheel bearings by rotating wheel by hand and tightening slotted nut until bearing binds SLIGHTLY. Then, loosen nut until nearest slot and hole in spindle line up. Install cotter pin. Correct end play of adjusted assembly is 0.002 to 0.005 inches.

11. Put a coating of grease on inside of dust cap and install dust cap on end of wheel spindle.

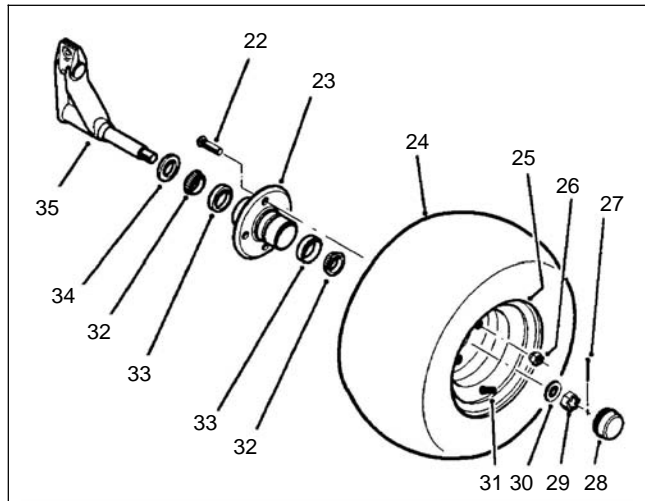

Figure 3



# Electrical Diagrams

## Table of Contents

Electrical Schematic .....	3
Main Harness Drawing .....	4
Main Harness Wiring Diagram .....	5
Control Panel Harness Drawing .....	6
Control Panel Wiring Diagram .....	7
Tiller Harness Drawing and Wiring Diagram .....	8

This page is intentionally blank.

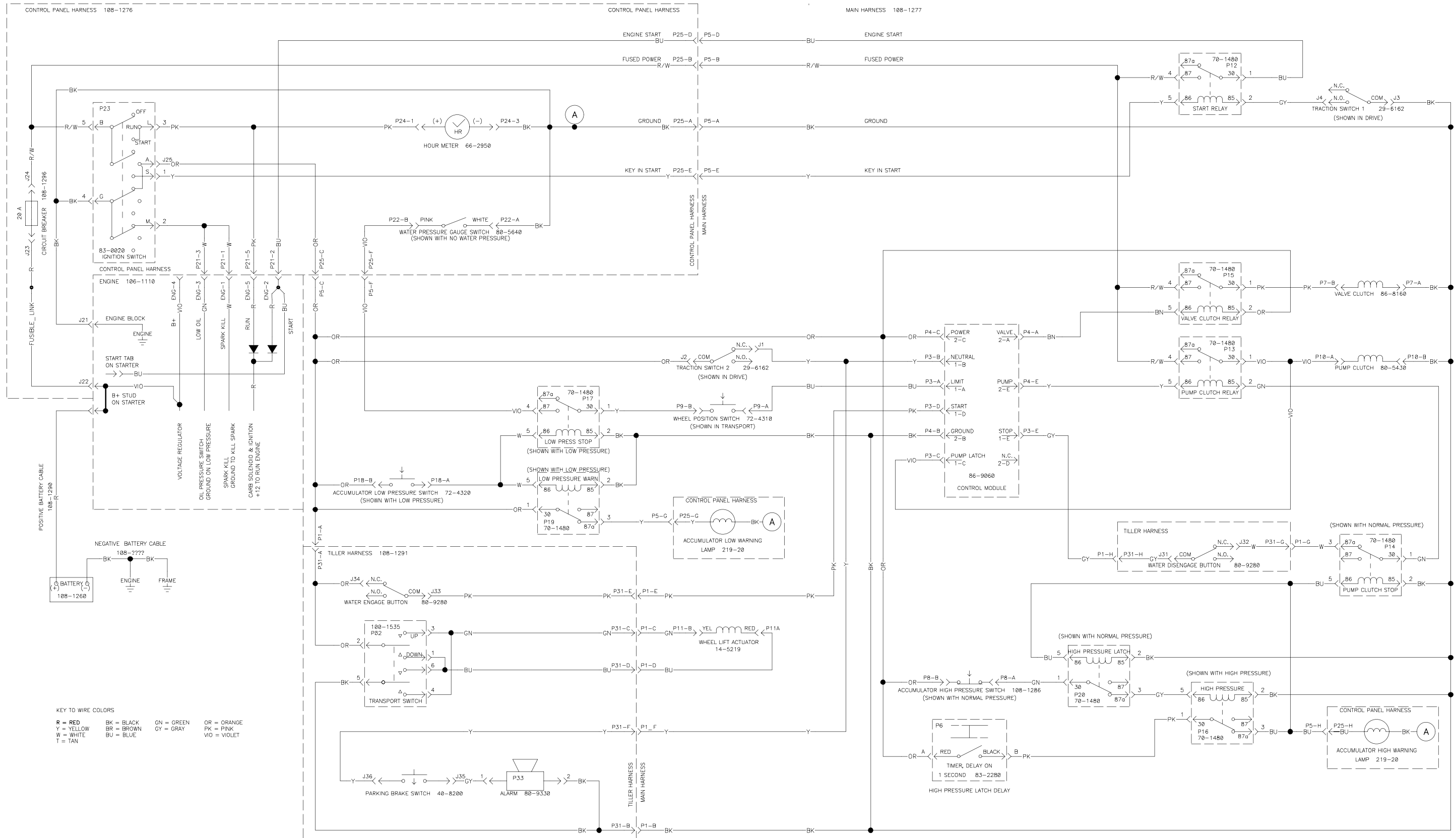

KEY TO WIRE COLORS  
 R = RED    BK = BLACK    GN = GREEN    OR = ORANGE  
 Y = YELLOW    BR = BROWN    GY = GRAY    PK = PINK  
 W = WHITE    BU = BLUE    VIO = VIOLET  
 T = TAN

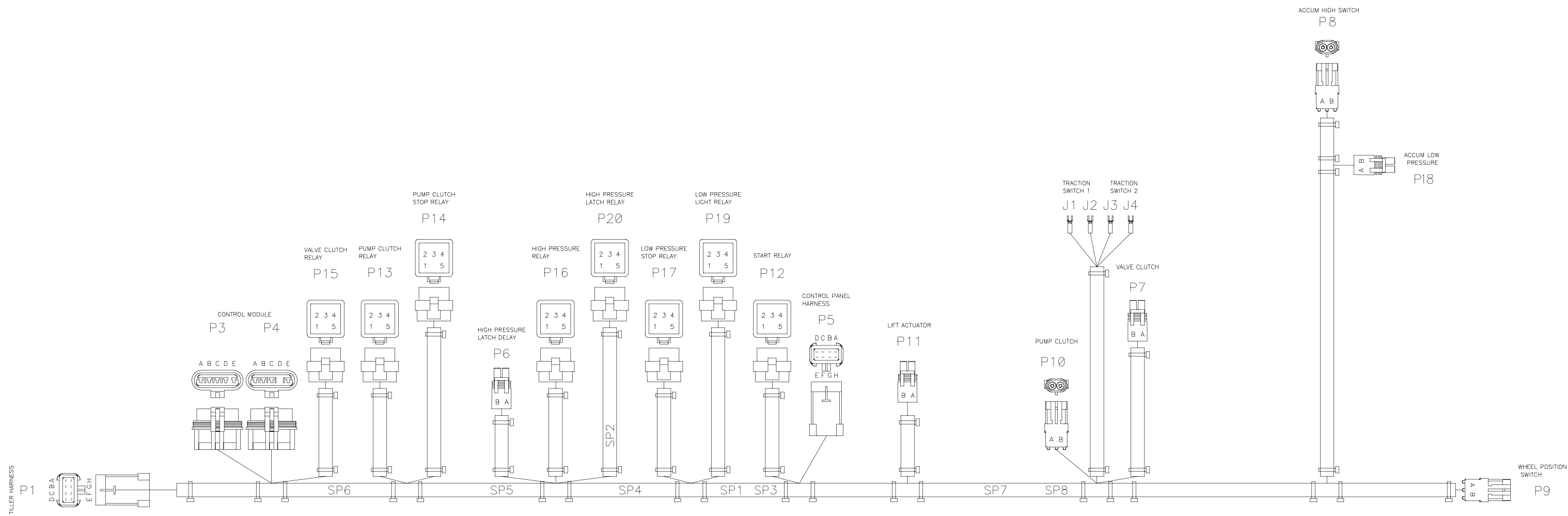



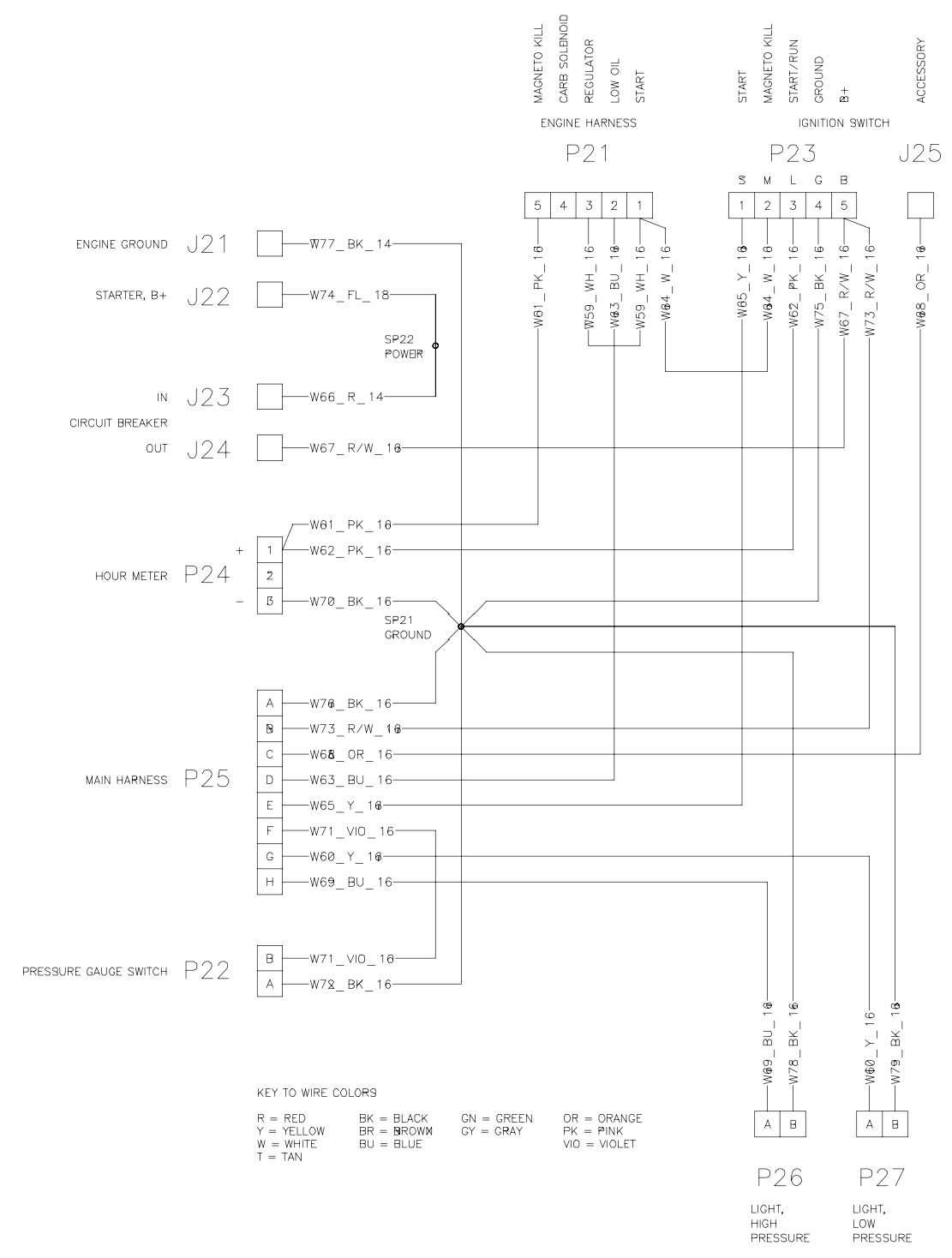
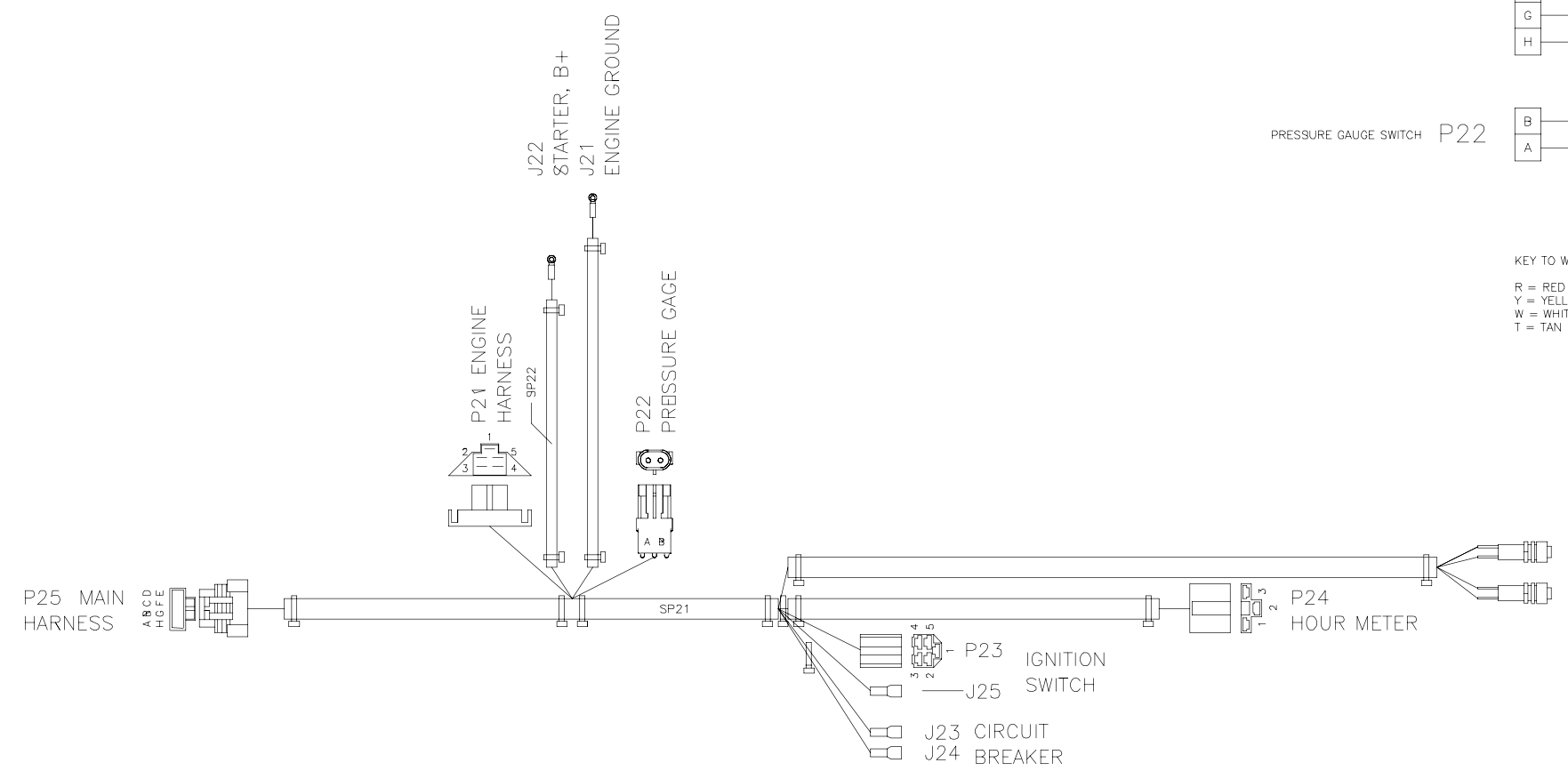

P26 LIGHT, HIGH PRESSURE  
P27 LIGHT, LOW PRESSURE

