

MODEL 460 AUTOMATIC ROTARY BLADE GRINDER

ASSEMBLY AND SERVICE MANUAL



WARNING

You must thoroughly read and understand this manual before assembling or maintaining the equipment, paying particular attention to the Warning & Safety instructions.

SAFETY INSTRUCTIONS



Safety Awareness Symbols are inserted into this manual to alert you to possible **Safety Hazards**. Whenever you see these symbols, follow their instructions.



The **Warning Symbol** identifies special instructions or procedures which, if not strictly observed, **could result in personal injury**.

The **Caution Symbol** identifies special instructions or procedures which, if not correctly followed, **could result in damage to or destruction of equipment**.

1. **KEEP GUARDS IN PLACE** and in working order.
2. **REMOVE WRENCHES AND OTHER TOOLS.**
3. **KEEP WORK AREA CLEAN.**
4. **DON'T USE IN DANGEROUS ENVIRONMENT.** Don't use Grinder in damp or wet locations. Machine is for indoor use only. Keep work area well lit.
5. **KEEP ALL VISITORS AWAY.** All visitors should be kept a safe distance from work area.
6. **MAKE WORK AREA CHILD-PROOF** with padlocks or master switches.
7. **DON'T FORCE THE GRINDER.** It will do the job better and safer if used as specified in this manual.
8. **USE THE RIGHT TOOL.** Don't force the Grinder or an attachment to do a job for which it was not designed.
9. **WEAR PROPER APPAREL.** Wear no loose clothing, gloves, neckties, or jewelry which may get caught in moving parts. Nonslip footwear is recommended. Wear protective hair covering to contain long hair.
10. **ALWAYS USE SAFETY GLASSES.**
11. **SECURE YOUR WORK.** Make certain that the rotary blade is securely fastened with the components provided before operating.
12. **DON'T OVERREACH.** Keep proper footing and balance at all times.
13. **MAINTAIN GRINDER WITH CARE.** Follow instructions in the Assembly and Service Manual for lubrication and preventive maintenance.
14. **DISCONNECT POWER BEFORE SERVICING.**
15. **REDUCE THE RISK OF UNINTENTIONAL STARTING.** Make sure all switches are OFF before plugging in the Grinder.
16. **USE RECOMMENDED ACCESSORIES.** Consult the manual for recommended accessories. Using improper accessories may cause risk of personal injury.
17. **CHECK DAMAGED PARTS.** A guard or other part that is damaged or will not perform its intended function should be properly repaired or replaced.
18. **KNOW YOUR EQUIPMENT.** Read this manual carefully. Learn its application and limitations as well as specific potential hazards.
19. **KEEP ALL SAFETY DECALS CLEAN AND LEGIBLE.** If safety decals become damaged or illegible for any reason, replace immediately. Refer to replacement parts illustrations in Service Manual for the proper location and part numbers of safety decals.
20. **DO NOT OPERATE THE GRINDER WHEN UNDER THE INFLUENCE OF DRUGS, ALCOHOL, OR MEDICATION.**

SAFETY INSTRUCTIONS



IMPROPER USE OF GRINDING WHEEL MAY CAUSE BREAKAGE AND SERIOUS INJURY.

Grinding is a safe operation if the few basic rules listed below are followed. These rules are based on material contained in the ANSI B7.1 Safety Code for "Use, Care and Protection of Abrasive Wheels". For your safety, we suggest you benefit from the experience of others and carefully follow these rules.

DO

1. **DO** always **HANDLE AND STORE** wheels in a **CAREFUL** manner.
2. **DO VISUALLY INSPECT** all wheels before mounting for possible damage.
3. **DO CHECK MACHINE SPEED** against the established maximum safe operating speed marked on wheel.
4. **DO CHECK MOUNTING FLANGES** for equal and correct diameter.
5. **DO USE MOUNTING BLOTTERS** when supplied with wheels.
6. **DO** be sure **WORK REST** is properly adjusted.
7. **DO** always **USE A SAFETY GUARD COVERING** at least one-half of the grinding wheel.
8. **DO** allow **NEWLY MOUNTED WHEELS** to run at operating speed, with guard in place, for at least one minute before grinding.
9. **DO** always **WEAR SAFETY GLASSES** or some type of eye protection when grinding.
10. **DO TURN OFF COOLANT** before stopping to avoid creating an out-of-balance condition.

DON'T

1. **DON'T** use a cracked wheel or one that **HAS BEEN DROPPED** or has become damaged.
2. **DON'T FORCE** a wheel onto the machine **OR ALTER** the size of the mounting hole. If wheel won't fit the machine, get one that will.
3. **DON'T** ever **EXCEED MAXIMUM OPERATING SPEED** established for the wheel.
4. **DON'T** use mounting flanges on which the bearing surfaces **ARE NOT CLEAN, FLAT AND FREE OF BURRS.**
5. **DON'T TIGHTEN** the mounting nut **EXCESSIVELY.**
6. **DON'T** grind on the **SIDE OF THE WHEEL** (see Safety Code B7.2 for exception).
7. **DON'T** start the machine until the **WHEEL GUARD IS IN PLACE.**
8. **DON'T JAM** work into the wheel.
9. **DON'T STAND DIRECTLY IN FRONT** of a grinding wheel whenever a grinder is started.
10. **DON'T FORCE GRINDING** so that motor slows noticeably or work gets hot.



AVOID INHALATION OF DUST generated by grinding and cutting operations. Exposure to dust may cause respiratory ailments. Use approved NIOSH or MSHA respirators, safety glasses or face shields, and protective clothing. Provide adequate ventilation to eliminate dust, or to maintain dust level below the Threshold Limit Value for nuisance dust as classified by OSHA.

This machine is intended for grinding the rotary blades from a rotary type mowing unit ONLY. Any use other than this may cause personal injury and void the warranty.

To assure the quality and safety of your machine and to maintain the warranty, you **MUST** use original equipment manufactures replacement parts and have any repair work done by a qualified professional.



ALL operators of this equipment must be thoroughly trained **BEFORE** operating the equipment.



Do not use compressed air to clean grinding dust from the machine. This dust can cause personal injury as well as damage to the grinder. Machine is for indoor use only. Do not powerwash machine.

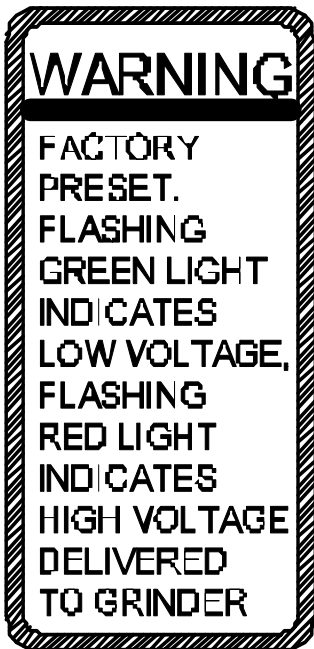

The grinder is equipped with a high/low voltage relay (LVR) which is factory preset at 100 VAC low voltage trip and 140 VAC high voltage trip. If the power supply line does not deliver a minimum of 100 VAC and a maximum of 140 VAC power under load, the relay will open and trip out the starter. If this occurs, your power supply line is inadequate and must be correct before proceeding further with the grinder.

A steady green light indicates - Power Up/ Fault cleared.

A steady red light indicates - Relay energized

A flashing red light indicates - Overvoltage trip

A flashing green light indicates - Undervoltage trip

CONTENTS

| | |
|-----------------------------------|--------------|
| Warnings | Page 2 - 4 |
| Contents and Specifications | Page 4 |
| Assembly | Page 6 - 8 |
| Maintenance | Page 9 - 11 |
| Adjustments | Page 12 - 18 |
| Control Box Component I.D. | Page 20 |
| Electrical Schematic | Page 21-23 |
| Electrical Wiring Diagram | Page 24 |
| Troubleshooting | Page 25 - 35 |
| Parts List | Page 36 - 49 |

SPECIFICATIONS

| | |
|-------------------------------|-------------------------------|
| Electrical Requirements | 115V 50/60 Hz, 15-amp circuit |
| Net Weight | 890 lbs [404 kg] |
| Shipping Weight | 1080 lbs [490 kg] |
| Maximum Grinding Length | 34 in. [86 cm] |
| Sound Level | Less than 75 Db |

SKILL AND TRAINING REQUIRED FOR SERVICING

This Service Manual is designed for technicians who have the necessary mechanical and electrical knowledge and skills to reliably test and repair the 460 Rotary Blade Grinder. For those without that background, service can be arranged through a local distributor.

This Manual presumes that you are already familiar with the normal operation of the Grinder. If not, you should read the Operators Manual, or do the servicing in conjunction with someone who is familiar with its operation.



PERSONS WITHOUT THE NECESSARY KNOWLEDGE AND SKILLS SHOULD NOT REMOVE THE CONTROL BOX COVER OR ATTEMPT ANY INTERNAL TROUBLESHOOTING, ADJUSTMENTS, OR PARTS REPLACEMENT!

If you have questions not answered in this manual, please call your distributor. They will contact the manufacturer if necessary.

TORQUE REQUIREMENTS

Throughout this manual we refer to torque requirements as "firmly tighten" or the like. For more specific torque values, refer to the information below.

Bolts Going into a Nut, or Into a Thread Hole in Steel.

Refer to table at the right.

Bolts Going into a Thread Hole in Aluminum.



Use the Grade 2 values in the table at the right.

Socket-Head Screws

Use the Grade 8 values in the table at the right.

Machine Screw

- No. 6 Screws: 11 in.-lbs [0.125 kg-m]
- No. 8 Screws: 20 in.-lbs [0.23 kg-m]
- No. 10 Screws: 32 in.-lbs [0.37 kg-m]

| | GRADE 2  SMOOTH HEAD | GRADE 5  3 MARKS on HEAD | GRADE 8  6 MARKS on HEAD |
|-----------------|---|---|---|
| 1/4 In. thread | 6 ft-lbs (0.8 kg-m) | 9 ft-lbs (1.25 kg-m) | 13 ft-lbs (1.8 kg-m) |
| 5/16 In. thread | 11 ft-lbs (1.5 kg-m) | 18 ft-lbs (2.5 kg-m) | 28 ft-lbs (3.9 kg-m) |
| 3/8 In. thread | 19 ft-lbs (2.6 kg-m) | 31 ft-lbs (4.3 kg-m) | 46 ft-lbs (6.4 kg-m) |
| 7/16 In. thread | 30 ft-lbs (4.1 kg-m) | 50 ft-lbs (6.9 kg-m) | 75 ft-lbs (10.4 kg-m) |
| 1/2 In. thread | 45 ft-lbs (6.2 kg-m) | 75 ft-lbs (10.4 kg-m) | 115 ft-lbs (15.9 kg-m) |

ASSEMBLY INSTRUCTIONS

UNPACK THE CARTONS

NOTE: Before you install the machine, read the following assembly procedure completely. Then study "Getting to Know Your Bedknife Grinder" in the Operators Manual.

Use care when unpacking. Double-check the packing cartons for any miscellaneous items before discarding.

Inspect all items for shipping damage as they are removed from the shipping containers. If you find any damage, notify the carrier's claims agent and do not proceed further until the damage has been inspected by the agent. Refer also to the "Shipping and Receiving Instructions" packed with the unit.

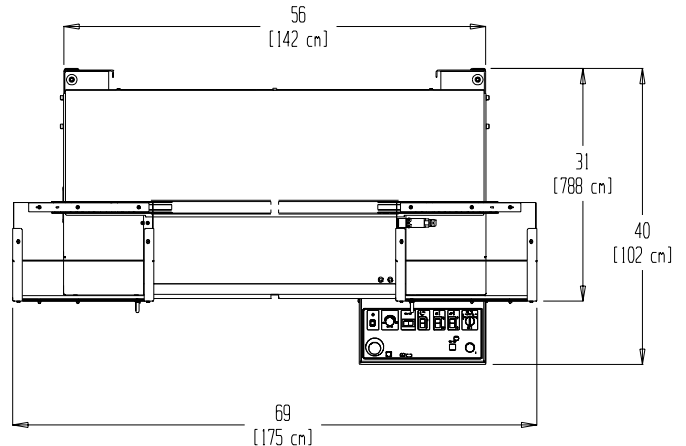

FIG. 1

Remove the Grinder from the Pallet

To remove the Grinder from the wood pallet, unbolt the four brackets that hold each end of the Grinder legs to the bottom of the pallet.



THE GRINDER WEIGHS 920 LBS [417 KG]. TO LIFT, USE POWER EQUIPMENT

The machine has adjustable feet that are located in holes in the wood pallet. Lift machine up straight to clear the pallet and then move machine to final position on floor.

Remove any additional shipping straps, and window protective sheets after positioning unit on the floor.

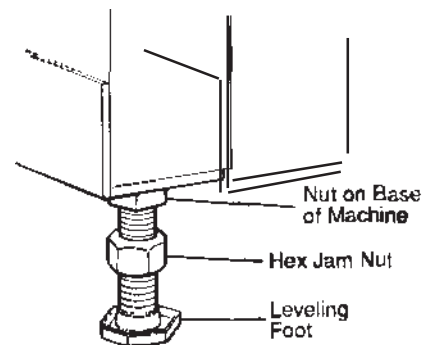

FIG. 2

LOCATE AND LEVEL THE GRINDER

Set the Grinder on a level concrete floor, on a single uncracked slab of concrete

The 460 Rotary Blade Grinder will require an operating area of about 75" W x 75" D x 75" H (190 x 190 x 190 cm). The machine operator will operate the unit from the front of the machine. Position the base to allow sufficient operating room in front of the machine. See FIG. 1.

Place level on the top of the Traverse Base. Adjust the leveling feet as necessary to bring to level. See FIG. 2.

Place a level across the Traverse Base from front to rear. Adjust the leveling feet on the end of the machine as necessary to level.

When both front to back and side to side leveling procedures have been completed, thread the hex jam nuts up against the nut that is welded to the bottom until they lock into place. Be careful not to move the leveling feet during this process. See FIG. 2. Make certain that all four leveling feet are firmly contacting the floor.

Recheck with level after locking nuts are firmly tightened.

ASSEMBLY INSTRUCTIONS (Continued)

APPLY POWER



BEFORE YOU APPLY POWER TO THE GRINDER, REFER TO THE "IMPORTANT GROUNDING INSTRUCTIONS" ON PAGE 9.



FIG. 4

115 Volt Model Only. Plug the control box power cord into a standard 115V AC 15-amp grounded receptacle. See FIG. 4.

220 Volt Model Only. For 220 Volt Applications order Part No. 4600951, which includes a 230 to 115 Volt Step Down Transformer. See Details on page 8.

IT IS RECOMMENDED THAT THIS 460 ROTARY BLADE GRINDER HAS ITS OWN PERMANENT POWER CONNECTION FROM THE POWER DISTRIBUTION PANEL, WITH NO OTHER MAJOR POWER DRAW EQUIPMENT ON THE SAME LINE.



IT IS REQUIRED THAT THE POWER DELIVERED TO THIS GRINDER IS 115 VAC - 15 AMPS. THE TOLERANCE ON THIS POWER REQUIREMENT IS +/- 5%. THEREFORE THE MINIMUM VOLTAGE REQUIREMENT IS 109VAC WITH 15 AMPS. VOLTAGE MUST BE CHECKED WITH ALL EQUIPMENT UNDER LOAD (OPERATING) ON THE CIRCUIT.

DO NOT OPERATE THIS GRINDER WITH AN EXTENSION CORD.



PROPER GROUNDING OF THE RECEPTACLE GROUND IN YOUR BUILDING MUST BE VERIFIED. IMPROPER GROUNDING IN YOUR BUILDING MAY CAUSE THE GRINDER TO MALFUNCTION.

FOR 15 AMP RATED LARGE MACHINES

For 0 to 30 Feet from panel to receptacle = Use 14 Ga. Wire.
For 30 to 50 Feet from panel to receptacle = Use 12 Ga. Wire.
For 50 to 80 Feet from panel to receptacle = Use 10 Ga. Wire.
For 80 to 140 Feet from panel to receptacle = Use 8 Ga. Wire.

For 0 to 9 Meters from panel to receptacle = Use 2.5mm Wire.
For 9 to 15 Meters from panel to receptacle = Use 4.0mm Wire.
For 15 to 24 Meters from panel to receptacle = Use 6.0mm Wire.
For 24 to 42 Meters from panel to receptacle = Use 10.0mm Wire.

The grinder is equipped with a high/low voltage relay (LVR) which is factory preset at 100 VAC low voltage trip and 140 VAC high voltage trip. If the power supply line does not deliver a minimum of 100 VAC and a maximum of 140 VAC power under load, the relay will open and trip out the starter. If this occurs, your power supply line is inadequate and must be correct before proceeding further with the grinder.

A steady green light indicates - Power Up/Fault cleared.

A steady red light indicates - Relay energized

A flashing red light indicates - Overvoltage trip

A flashing green light indicates - Undervoltage trip

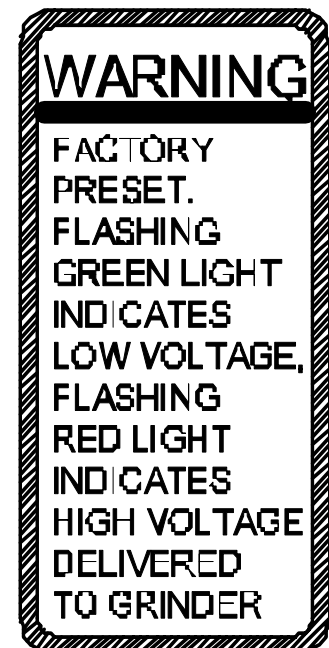

ASSEMBLY INSTRUCTIONS (Continued)

FOR 220-240 V 50 or 60Hz applications Product No. 4600951 should be ordered.

4600951 includes a 2 KVA 220-240 Volt Step Down to 110-120 Volt 50/60 Hz transformer which is prewired.

The wiring diagram is shown in FIG. 5.

The power cord has no connector. A connector which is appropriate for your locality and 220 volt, 8 amp application should be installed.

! **USE ONLY A QUALIFIED ELECTRICIAN TO COMPLETE THE INSTALLATION.**

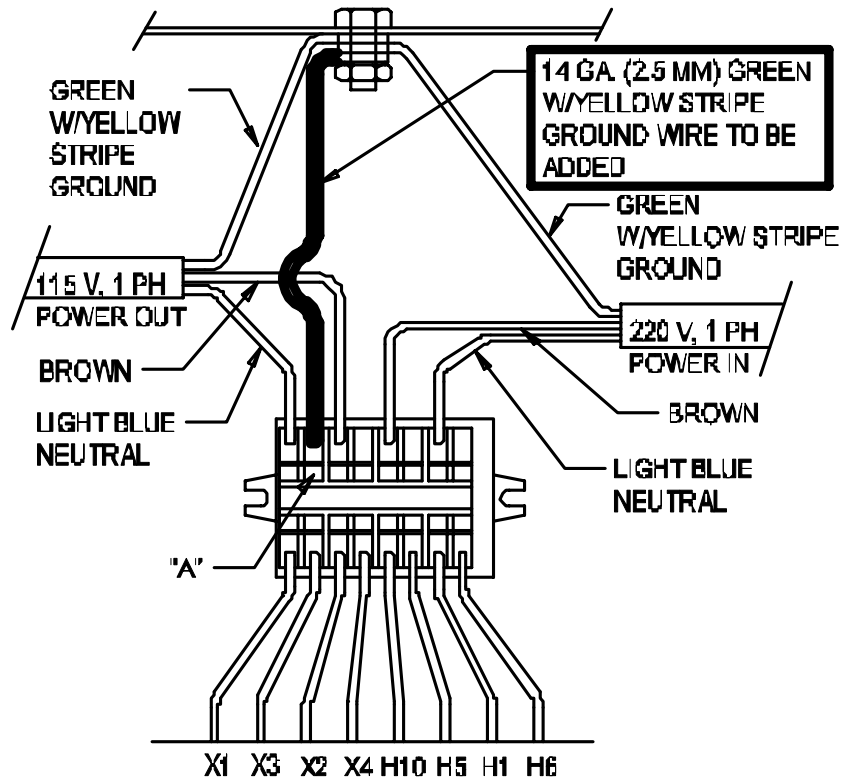

INDIVIDUALLY WIRE NUT TRANSFORMER LEADS H2, H3, H4, H7, H8 AND H9

FIG. 5

INSTALL THE GREEN W/YELLOW STRIPE WIRE SUPPLIED INTO THE TERMINAL BLOCK IN THE HOLE OPPOSITE WIRE X3 AS SHOWN. TO INSTALL THE WIRE INSERT A SMALL SCREWDRIVER INTO THE CAVITY MARKED "A" TO OPEN THE WIRE HOLE.

ATTACH THE OTHER END OF THE GREEN W/YELLOW STRIPE WIRE SUPPLIED TO THE GROUND STUD ON THE TRANSFORMER.

IMPORTANT GROUNDING INSTRUCTIONS

In case of a malfunction or breakdown, grounding reduces the risk of electrical shock by providing a path of least resistance for electrical current.

This Grinder has an electrical cord with an equipment grounding conductor and a grounding plug. The plug must be plugged into a matching outlet that is properly installed and grounded according to all local or other appropriate electrical codes and ordinances.

Before plugging in the Grinder, make sure it will be connected to a supply circuit protected by a properly-sized circuit breaker or fuse. SEE SERIAL NUMBER PLATE FOR FULL LOAD AMP RATING OF YOUR MACHINE.

Never modify the plug provided with the machine--if it won't fit the outlet, have a proper outlet and circuit installed by a qualified electrician.



ALWAYS PROVIDE A PROPER ELECTRICAL GROUND FOR YOUR MACHINE. AN IMPROPER CONNECTION CAN CAUSE A DANGEROUS ELECTRICAL SHOCK. IF YOU ARE UNSURE OF THE PROPER ELECTRICAL GROUNDING PROCEDURE, CONTACT A QUALIFIED ELECTRICIAN.

MAINTENANCE & LUBRICATION

DAILY MAINTENANCE IS SPECIFIED ON PAGE 6 OF THE OPERATOR'S MANUAL, AND IS TO BE PERFORMED BY THE OPERATOR. LISTED BELOW ARE PERIODIC MAINTENANCE ITEMS TO BE PERFORMED BY YOUR COMPANY'S MAINTENANCE DEPARTMENT:

1. Monthly check fan air filter located on the left side panel, inside the grinding enclosure. Replace if necessary.
2. Monthly check movement of the blade clamping blocks. Adjust tension on brass tipped setscrews. Remove and clean any parts that are sticking or binding. Reassemble taking care to line up all balancing marks. Check balance.
3. Check Traverse bearings at least every month. Lubricate per procedure on next page. Replace when there is excess movement of grinding heads due to bearings.
4. Every two months check the movement of the grinding heads in the vertical directions. Remove shoulder bolts, springs, and ratchet handles, clean all surfaces and re-assemble.
5. Every Six months check traverse belt tension. Adjust tension per procedure in adjustments section of this manual.
6. Every six months to a year check infeed screws on the top and bottom grinding heads. Remove guard and clean and grease if needed. Make any needed adjustments to the locknut, coupling, or stepper motor locations (See adjustments section for details.)
7. Every six months check brass backlash nut and rubber bellows on the infeed shaft. Replace if worn. (See adjustments section for details.)
8. Check the brushes on the auto traverse drive motor and spin motor once a year. Replace as necessary. See Troubleshooting Section.

MAINTENANCE & LUBRICATION (Continued)

LUBRICATION OF LINEAR BEARINGS

STEP 1--Thoroughly clean the shafts.

STEP 2--Flood spray the four shafts with a spray lubricant (**VIEW LIST OF RECOMMENDED LUBRICANTS BELOW**) until the lubricant is dripping off the shafts. See FIG. 6 Then run the carriage back and forth through its full range of travel. This will carry the lubricant into the bearings.

STEP 3--With a clean rag, wipe off the excess amount of lubricant from the shafts. Run the carriage back and forth through its full range of travel and wipe the shafts after each traverse. Repeat until the shafts are dry to the feel. This completes the lubrication process.

If the unit will be shut down for an extended period of time, more than two weeks see Lubrication Frequency below.

RECOMMENDED LUBRICANTS:

- Waylube Oil
- Light Weight Oils
- Petroleum Based Grease
- 3-in-1 Oils

NOT RECOMMENDED LUBRICANTS:

- WD-40
- PTFE Spays or Teflon based sprays.
- Fluorocarbons
- Silicon Oils, Grease or Spray.



DO NOT REPEATEDLY CLEAN THE SHAFTING WITH ALCOHOL! THIS WILL INCREASE THE WEAR TO THE BEARING LINER.

LUBRICATION FREQUENCY

The lubrication frequency is to check the shaft monthly during grinder operation.

If the unit will be shut down for an extended period of time, more than two weeks, then the shafts and other appropriate parts of the unit should be flooded with lubricant and that lubricant left in place until the unit is brought back into service. When the unit is brought back into service the full lubrication procedure as stated above should be repeated.

(WD40 is a registered trademark of the WD40 company,
Teflon is a registered trademark of the Dupont Corporation.)

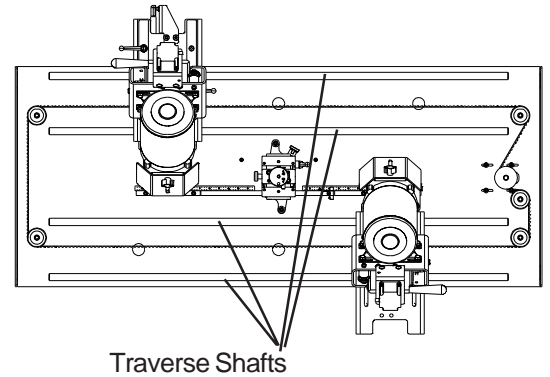

FIG. 6

MAINTENANCE (Continued)

CLEANING AND MAINTENANCE GUIDELINES FOR POLYCARBONATE WINDOWS

Cleaning Instructions

DO NOT USE GASOLINE
Adherence to regular and proper
cleaning procedures is recommended
to preserve appearance and performance.

Washing to Minimize Scratching

Wash polycarbonate windows with a mild dish washing liquid detergent and lukewarm water, using a clean soft sponge or a soft cloth. Rinse well with clean water. Dry thoroughly with a moist cellulose sponge to prevent water spots. Do not scrub or use brushes on these windows. Also, do not use butyl cellosolve in direct sunlight.

Fresh paint splashes and grease can be removed easily before drying by rubbing lightly with a good grade of VM&P naphtha or isopropyl alcohol. Afterward, a warm final wash should be made, using a mild dish washing liquid detergent solution and ending with a thorough rinsing with clean water.

Minimizing Hairline Scratches

Scratches and minor abrasions can be minimized by using a mild automobile polish. Three such products that tend to polish and fill scratches are Johnson paste Wax, Novus Plastic Polish #1 and #2, and Mirror Glaze plastic polish (M.G. M10). It is suggested that a test be made on a corner of the polycarbonate window with the product selected following the polish manufacturer's instructions.

Some Important "DON'TS"

- **DO NOT** use abrasive or highly alkaline cleaners on the polycarbonate windows.
- **Never** scrape polycarbonate windows with squeegees, razor blades or other sharp instruments.
- Benzene, gasoline, acetone or carbon tetrachloride should **NEVER** be used on polycarbonate windows.
- **DO NOT** clean polycarbonate windows in hot sun or at elevated temperatures.

Graffiti Removal

- Butyl cellosolve, (for removal of paints, marking pen inks, lipstick, etc.)
- The use of masking tape, adhesive tape or lint removal tools works well for lifting off old weathered paints.
- To remove labels, stickers, etc., the use of kerosene, VM&P naphtha or petroleum spirits is generally effective. When the solvent will not penetrate sticker material, apply heat (hair dryer) to soften the adhesive and promote removal.

GASOLINE SHOULD NOT BE USED!

ADJUSTMENTS

TO REPLACE THE CARRIAGE LINEAR BEARINGS

Outer Rail Bearings:

1. To replace the bearing on the top rail or bottom rail See Fig 7, first remove the grinding head. The Grinding head is secured to the Carriage base with 2 shoulder bolts and 2 adjustable handles. Then remove the screws for the bearing. Slide the bearing off the end of the shafts.
2. Clean the shaft. (Use 3-in-1 type oil or other lubrication that is specified in the "LUBRICATION OF LINEAR BEARINGS" section on page 10 of this manual.)
3. Slide the new bearing on the shaft and reinstall the screws and nuts. Move the proximity switches so that the grinding head can travel through its full range of motion. Move the head back and forth through this range of motion approximately 20 times. Reinstall Grinding heads.
NOTE: These bearings have a liner that interacts with the shafting. When installing a new bearing it goes through a breaking in process and transfers a thin film of this bearing material onto the shaft. This transfer creates the self lubrication condition and allows the bearings to run smoothly.

Inner Rail Bearings:

1. To replace a bearing on either of the two inner most rails See Fig 7., first remove the idler pulley that is at the end of the shaft where the bearing will be removed.
2. Remove the grinding head. The Grinding head is secured to the Carriage base with 2 shoulder bolts and 2 adjustable handles. Removed the screws for the bearing. Slide the bearing off the end of the shafts (Where pulley was removed).
3. Clean the shaft. (Use 3-in-1 type oil or other lubrication that is specified in the "LUBRICATION OF LINEAR BEARINGS" section on page 10 of this manual.)
4. Slide the new bearing on the shaft and reinstall the screws and nuts.
5. Reinstall the Idler pulley removed in step 1. Check the belt tension and make adjustment if needed. (see Traverse Belt Tension in Adjustments section.)
6. Move the proximity switches so that the grinding head can travel through its full range of motion. Move the head back and forth through this range of motion approximately 20 times. Reinstall the Grinding Heads.
NOTE: These bearings have a liner that interacts with the shafting. When installing a new bearing it goes through a breaking in process and transfers a thin film of this bearing material onto the shaft. This transfer creates the self lubrication condition and allows the bearings to run smoothly.

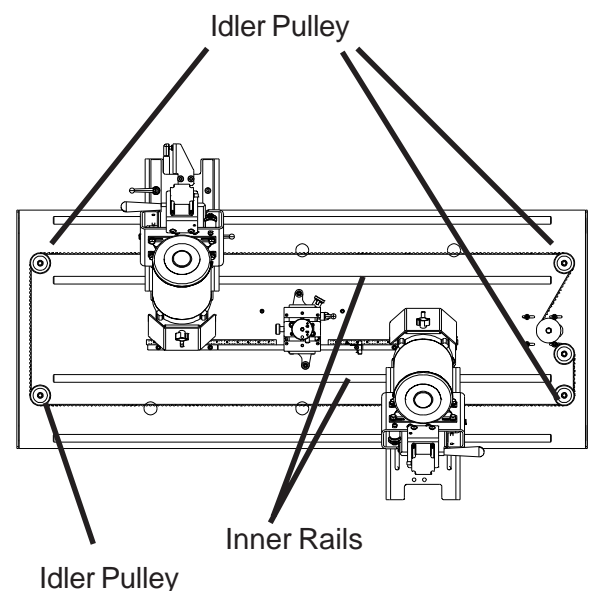
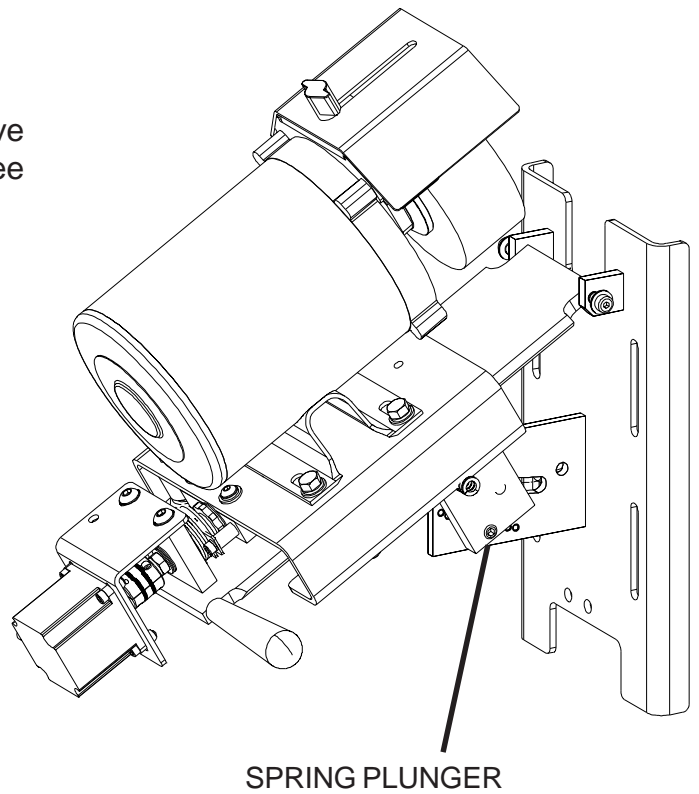

FIG. 7

ADJUSTMENTS (Continued)

SPRING PLUNGER (ANGLE POSITION)

Adjust the position of the spring plunger for a positive detent at each position, but still easily moveable. See FIG 8.



SPRING PLUNGER

FIG. 8

ADJUSTING FREEPLAY IN BLADE CLAMP SYSTEM

Adjust the brass tipped setscrews so that it removes all freeplay in the system but allows blade clamp cam system to move through full range of travel. There are 2 setscrews on 1 side of each clamp block (4 total). See FIG 9.

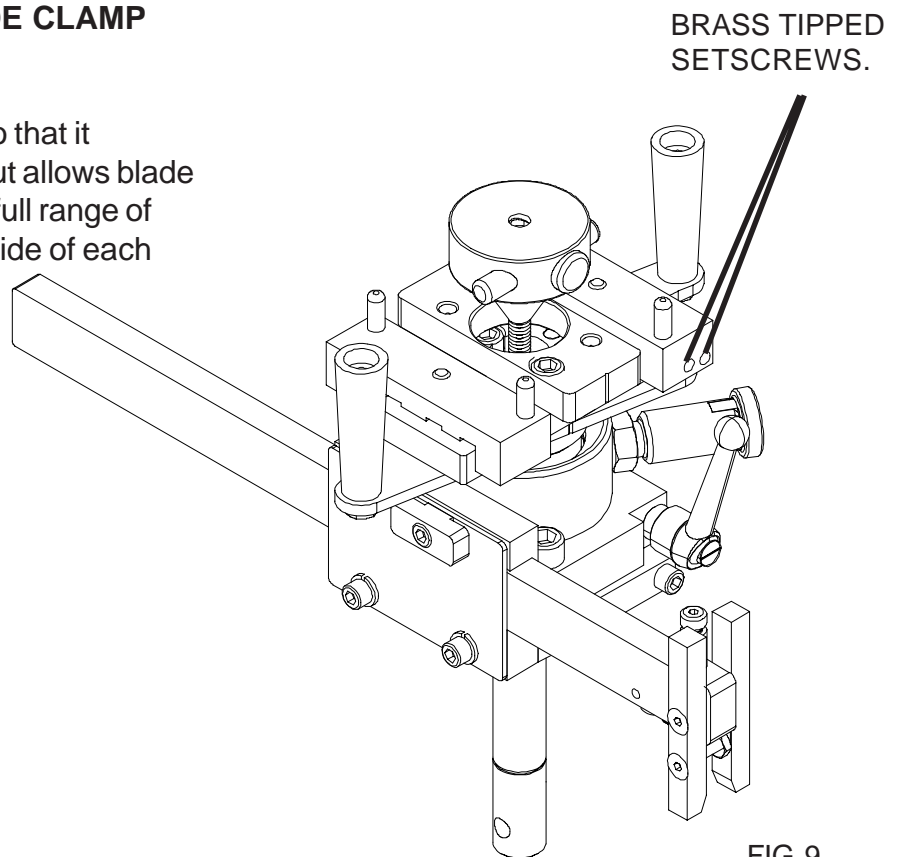

FIG. 9

ADJUSTMENTS (Continued)

PIVOT SHAFT CLAMP BLOCK ADJUSTMENT

To adjust the return position of the center support assembly, loosen the clamp bolt. See FIG. 10. Disengage the relief release system from bar by rotating it. This will allow the center support assembly to rotate. The springs located on the back of the traverse base return the assembly to the position so that the relief release system engages the bar located on the traverse base. With the clamp bolt loose the assembly should rotate on the pivot shaft. Adjust to position of the pivot shaft clamp block on the pivot shaft so that the relief release system engages the bar. Make sure the pivot shaft clamp block is against the snap ring located on the pivot shaft and tighten the clamp bolt. Test to make sure the system work with both left and right sided blades.

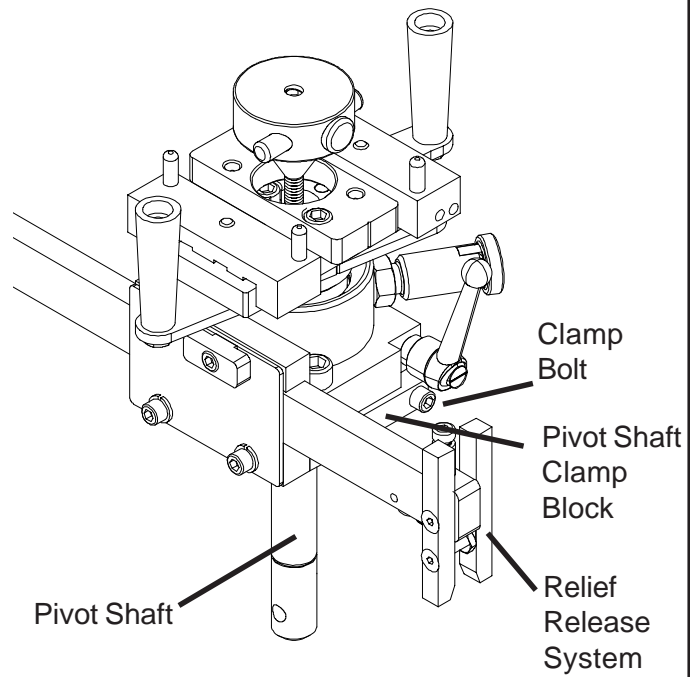

FIG. 10

BALANCER ASSEMBLY

There are notches on the side of the parts that are part of the balancing feature. See FIG 11. If the center support assembly is dismantled, the notches must be lined up on reassembly.

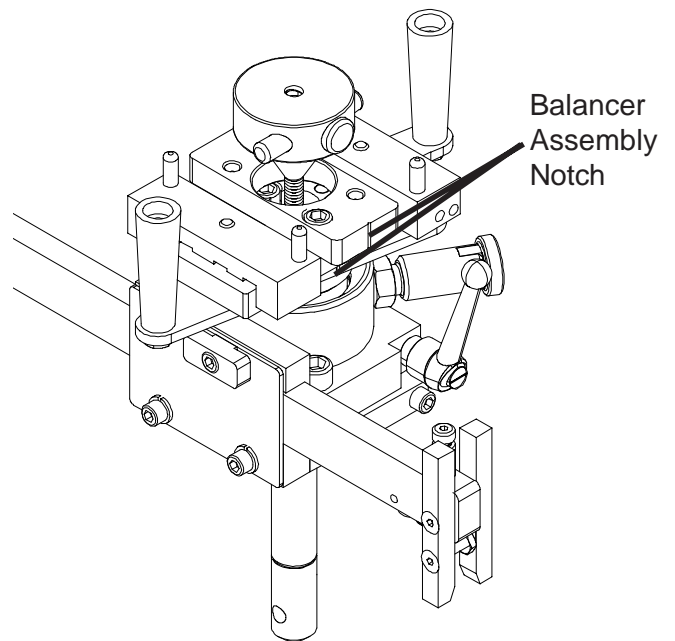

FIG. 11

ADJUSTMENTS (Continued)

CAM PLATE ALIGNMENT SETSCREW

To make adjustments to the cam plate start position loosen the nut located on the position setscrew and adjust the setscrew so that the relief slide bar pin engages the cam plate smoothly. See FIG 12 After this is adjusted lock the setscrew in place by tightening the nut on the setscrew.

The stop position for when the bottom head is moved to the left side of the grinder is done with the other setscrew. Make the adjustments as stated above and lock this in place.

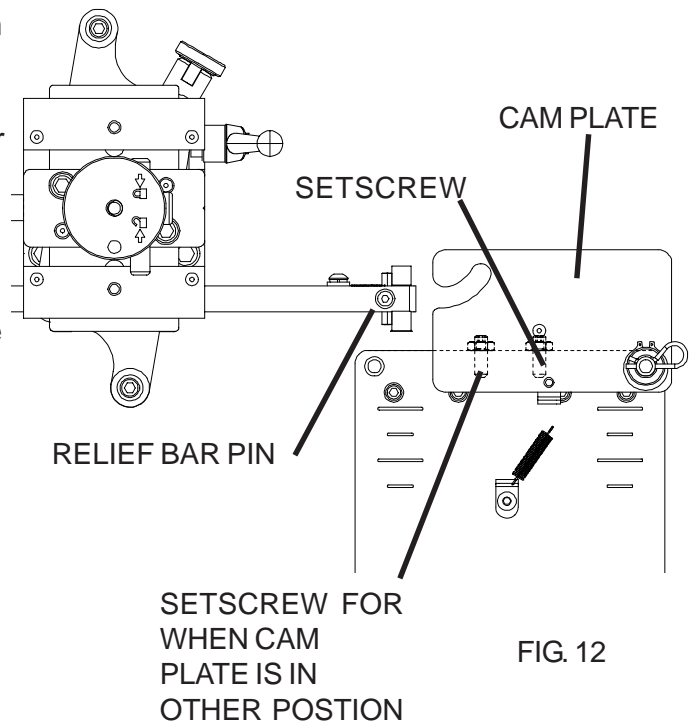

FIG. 12

TRAVERSE BELT TENSION

To adjust the belt tension, loosen the screws that hold the traverse motor to the traverse base. See FIG 13. Apply pressure (approximately 100lbs) to the motor toward the center of the machine. While applying pressure tighten the bolts that hold the motor in place. Check the tension on the belt.

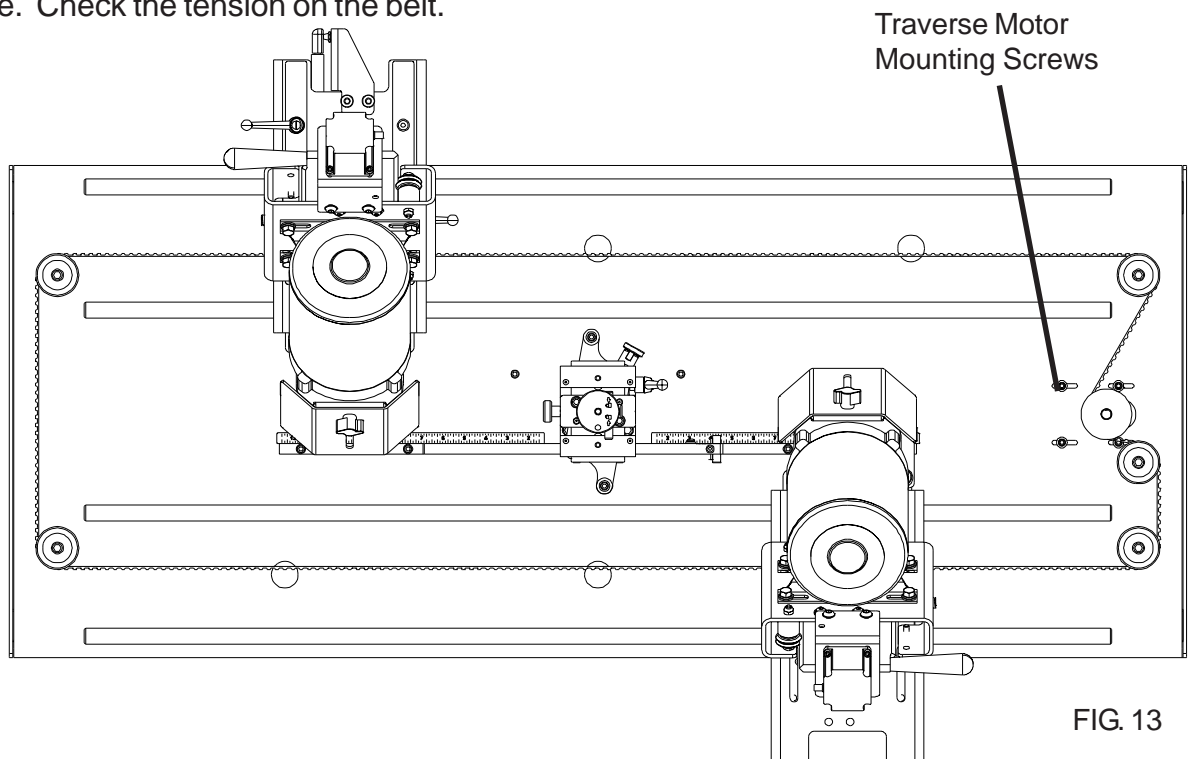

FIG. 13

ADJUSTMENT (Continued)

TO ADJUST THE PROXIMITY SWITCHES

For the proximity switches to work properly and reverse the direction of the carriage at each end of a traverse, a distance of $3/16$ in. $\pm 1/32$ [4.75 mm ± 0.75] must be maintained between the top of the switch and the actuator bracket on the bottom of the carriage. See FIG. 14.

To adjust the clearance, loosen one of the switch mounting nuts while tightening the other.

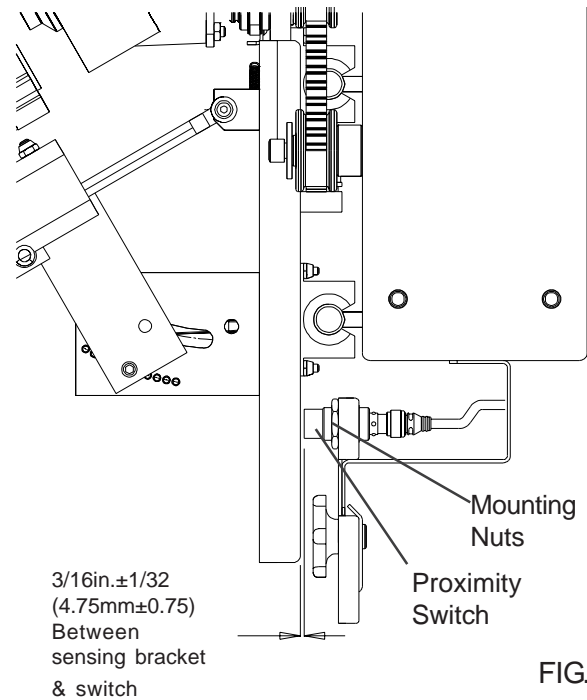

FIG. 14

ADJUSTING THE PRELOAD TENSION ON THE SMALL GRINDING HEAD SLIDE VEE ROLLERS

The small grinding head slide vee rollers are positioned two fixed and one adjustable on the side. To set the correct preload on the right side adjuster, tighten the setscrew in FIG. 15 until the spring is fully compressed solid, then back off $1/2$ turn.

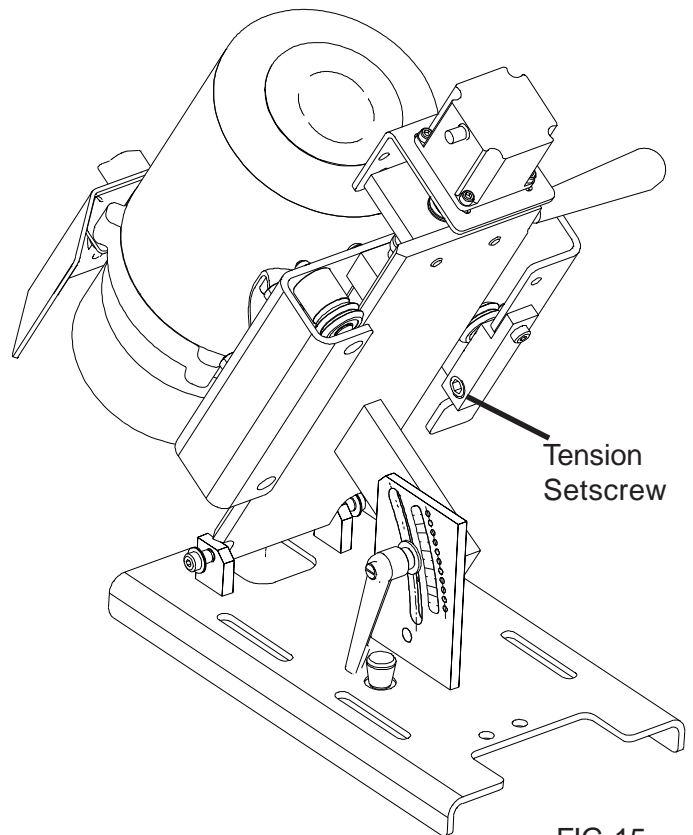

FIG. 15

ADJUSTMENTS (Continued)

TO ELIMINATE CARRIAGE INFEED BACKLASH

If there is backlash in the carriage infeed system, there are two adjusting points to check:

1. Conical washer and Shaft Backlash nut:

- A. Remove rubber bellows retainer and pull back bellows to get access to the Backlash Nut.
- B. Unscrew the shoulder bolt.
- C. Turn the machine on - this should apply holding power to the infeed motor (if this does not hold you will need to remove the two screws on that attach the infeed block to the V-Bearing/Motor Plate. *Note: this will free the head to float on the V-Bearings. Support the motor when removing the screws.* This will give access to the infeed shaft. use a wrench to hold the shaft.) Turn the shaft adjusting nut counterclockwise until the conical washers are touching each other. Continue turning the nut counterclockwise until the next notch is centered over the shoulder-bolt hole.
- D. Reinstall the shoulder bolt to lock the nut in position.
- E. Reinstall the rubber bellows.

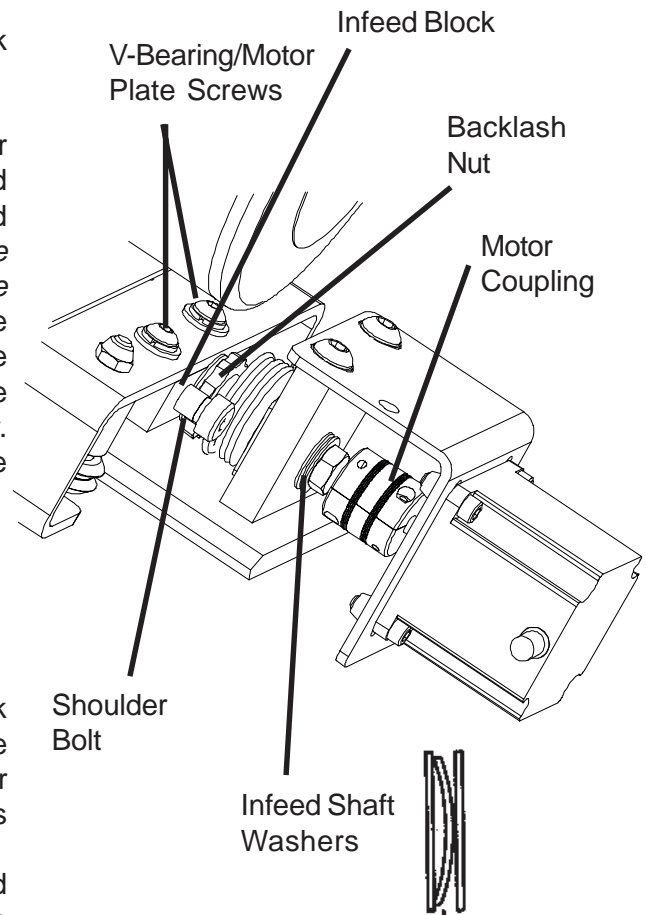

2. Washers at the infeed shaft mount block:

- A. Remove the two screws that attach the infeed block to the V-Bearing/Motor Plate. (Note: this will free the head to float on the V-Bearings. Support the motor when removing the screws.) This will allow access to the infeed shaft.
- B. Place a wrench on the end of the infeed shaft and tighten the hex nut which secures the infeed shaft to 100 in.-lbs [1.15 kg-m), then back it off 1/2 turn.
- C. Turn the machine on and test the infeed. It should move smoothly and freely. Make adjustments to the locknut if needed.
- D. Reinstall the screws removed in step 1.

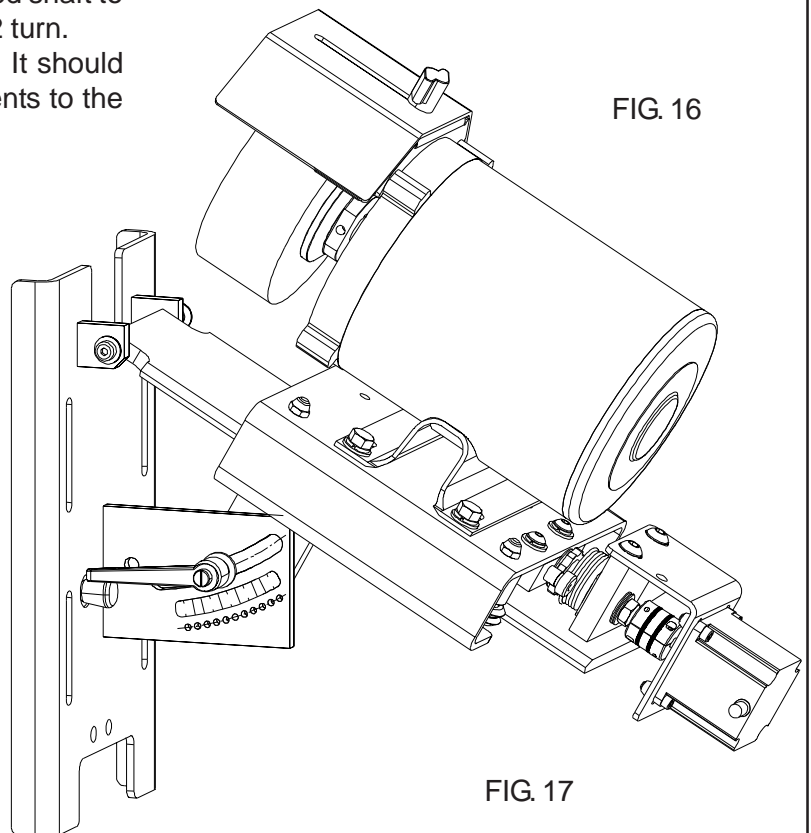

ADJUSTMENTS (Continued)

POTENTIOMETER ADJUSTMENTS TRAVERSE DRIVE CONTROL (TDC)

(Right Traverse) Forward Acceleration--Factory set at full (CCW) 8:30. Do not change this setting.

(Left Traverse) Reverse Acceleration--Factory set at full (CCW) 8:30. Do not change this setting.

Max. Speed--Set at 2:30 for maximum voltage of 90 Volts DC to the traverse motor. When voltage is above 90 volts DC, the traverse motor will start to pulsate and not run smoothly.

IR COMP--Factory set to 9:00. IR COMP is current (I) resistance (R) compensation (COMP).

IR COMP adjusts the output voltage of the drive which balances load to motor RPM. Regulation of a traverse motor may be improved by slight adjustment of the IR COMP trim pot clockwise from its factory-set position. Overcompensation causes the motor to oscillate or to increase speed when fully loaded. If you reach such a point, turn the IR COMP trim pot counterclockwise until the symptoms disappear.

(Right Traverse) Forward Torque--Factory set at full (CW) 11:00. Do not change this setting.

(Left Traverse) Reverse Torque--Factory set at full (CW) 11:00. Do not change this setting.

(DB) Dead Band is the potentiometer setting for the 50 or 60 Hz cycle control. Factory set to 3:00 for 60 Hz operation. Recalibrate to the 9:00 position for 50 Hz power.

Min. Speed--Factory set at full (CCW) 8:30. Do not change this setting.

Armature Voltage Selector switch (SW504) is on the top board and set to 90VDC. Do not change this setting.

Diagnostic LED's indicate the function that is currently being performed:

- * **POWER** indicates that ac power is being applied to the control.
- * **Limt FWD and REV** are not used and should not light up.

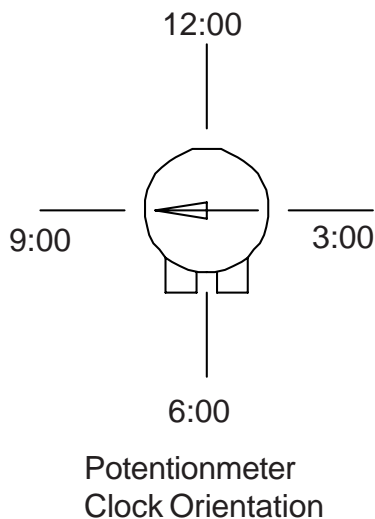

- FWD ACC - 8:30
- REV ACC - 8:30
- MAX SPD - 2:30
- IR COMP - 9:00
- REV TQ - 11:00
- FWD TQ - 11:00
- DB - 3:00 60Hz/
9:00 50Hz
- MIN SPD - 8:30
- TACH - NA

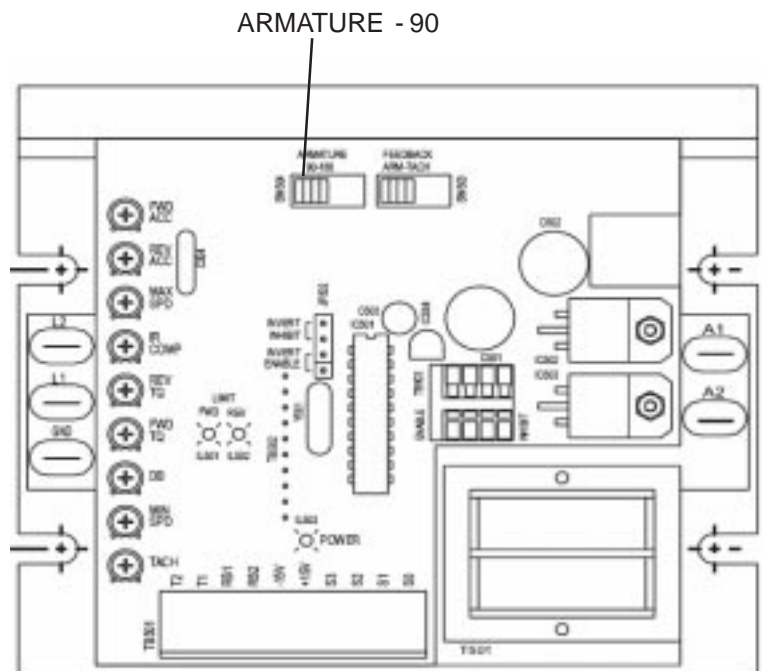

FIG. 18

ELECTRICAL TROUBLESHOOTING

SKILL AND TRAINING REQUIRED FOR ELECTRICAL SERVICING

This Electrical Troubleshooting section is designed for technicians who have the necessary electrical knowledge and skills to reliably test and repair the 460 Rotary Blade Grinder electrical system. For those without that background, service can be arranged through your local distributor.

This manual presumes that you are already familiar with the normal operation of the Grinder. If not, you should read the Operators Manual, or do the servicing in conjunction with someone who is familiar with its operation.

Persons without the necessary knowledge and skills should not remove the control box cover or attempt any internal troubleshooting, adjustments, or parts replacement.

If you have any question not answered in this manual, please call your distributor. They will contact the manufacturer if necessary.

WIRE LABELS

All wires on the 460 Rotary Blade Grindier have a wire label at each end for troubleshooting. The wire label has a code which tells you wiring information. The wire label has a seven position code. The first two digits are the wire number: 01-99. The next three numbers or letters are the code for the component to which the wire attaches. Example: LVR for Low Voltage Monitor. The last two numbers or letters are the number of the terminal on the component to which the wire attaches.

ELECTRICAL TROUBLESHOOTING INDEX

| | |
|-------------------------------|-------------|
| Componet Identification | Page 20 |
| Wiring Schematic | Pages 21-23 |
| Wiring Diagram | Page 24 |
| AC Main Power Controls | Page 25-27 |
| Grinding Motor Controls | Page 28-29 |
| Traverse Drive Controls | Page 30-31 |
| Proximity Switches | Page 32 |
| Fan Power | Page 33 |
| Light Power | Page 33 |
| Stepper Drive Controls | Page 34-35 |

460 MANUAL CONTROL PANEL IDENTIFICATION

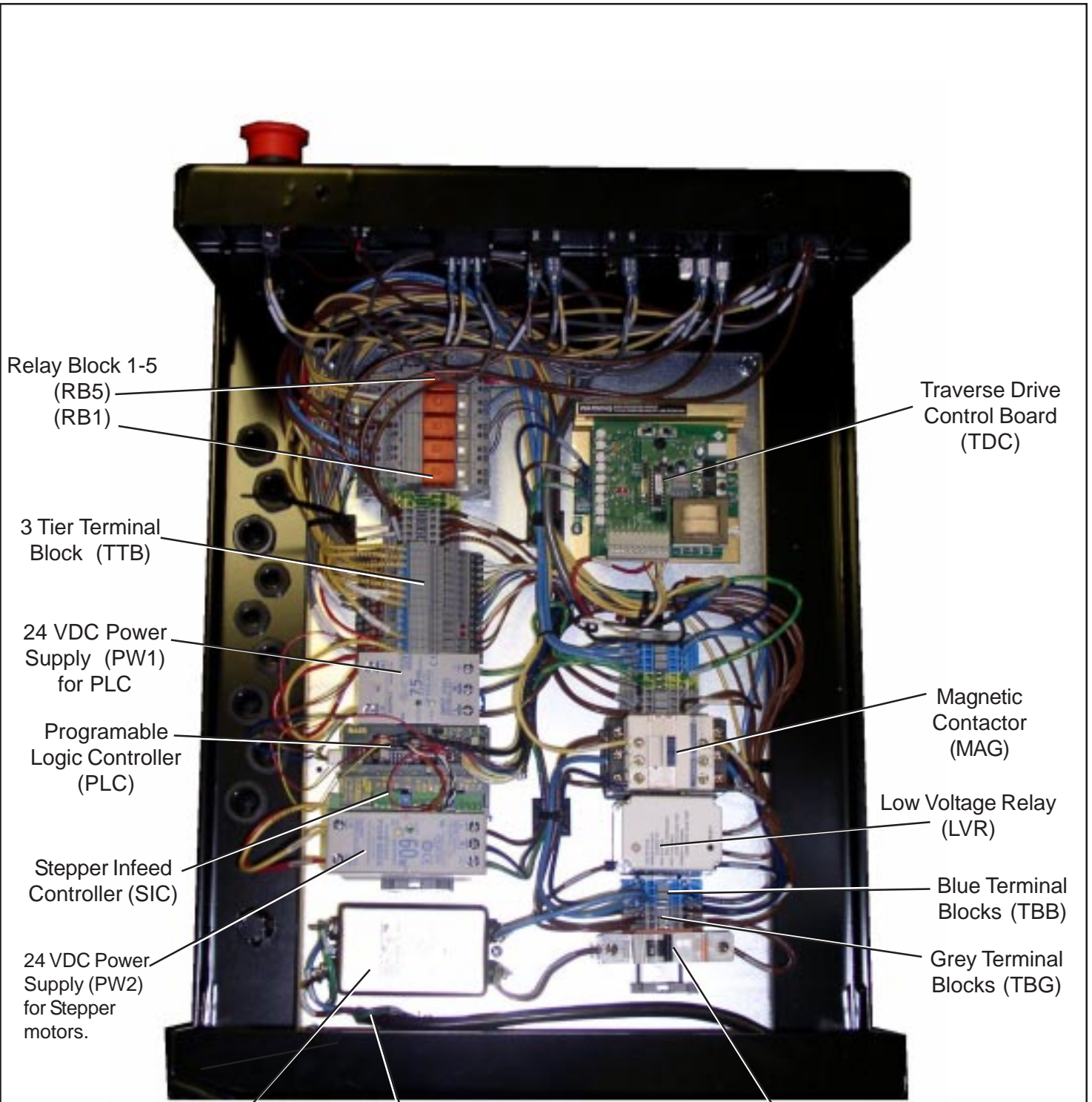

Relay Block 1-5
(RB5)
(RB1)

Traverse Drive
Control Board
(TDC)

3 Tier Terminal
Block (TTB)

24 VDC Power
Supply (PW1)
for PLC

Programable
Logic Controller
(PLC)

Magnetic
Contactor
(MAG)

Low Voltage Relay
(LVR)

Stepper Infeed
Controller (SIC)

Blue Terminal
Blocks (TBB)

24 VDC Power
Supply (PW2)
for Stepper
motors.

Grey Terminal
Blocks (TBG)

AC Filter
(FTR)

Main Ground Lug

Main Circuit
Breaker (MCB)

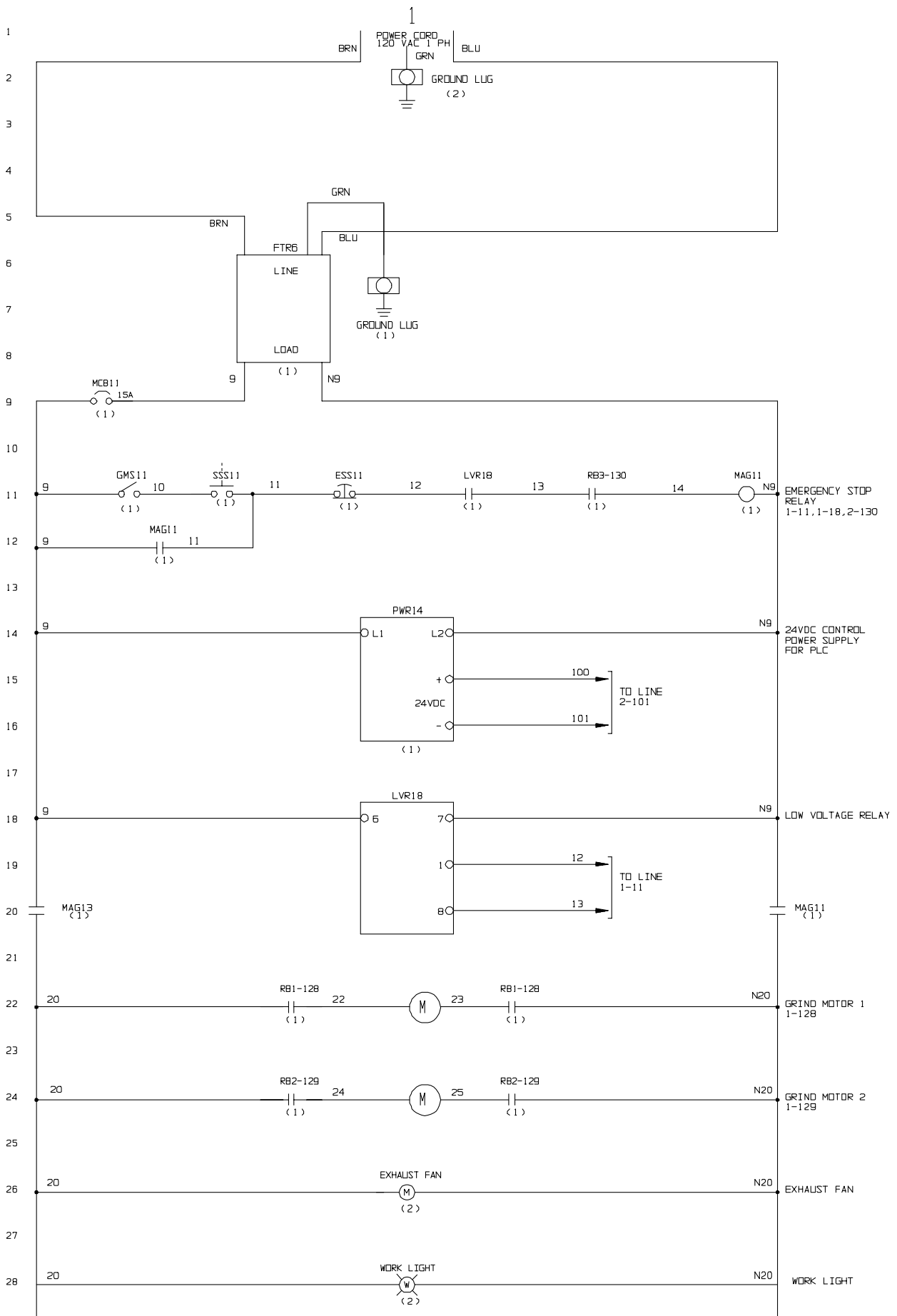

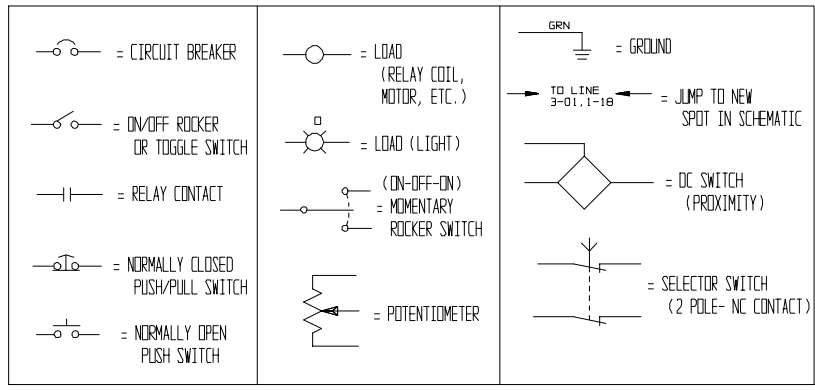
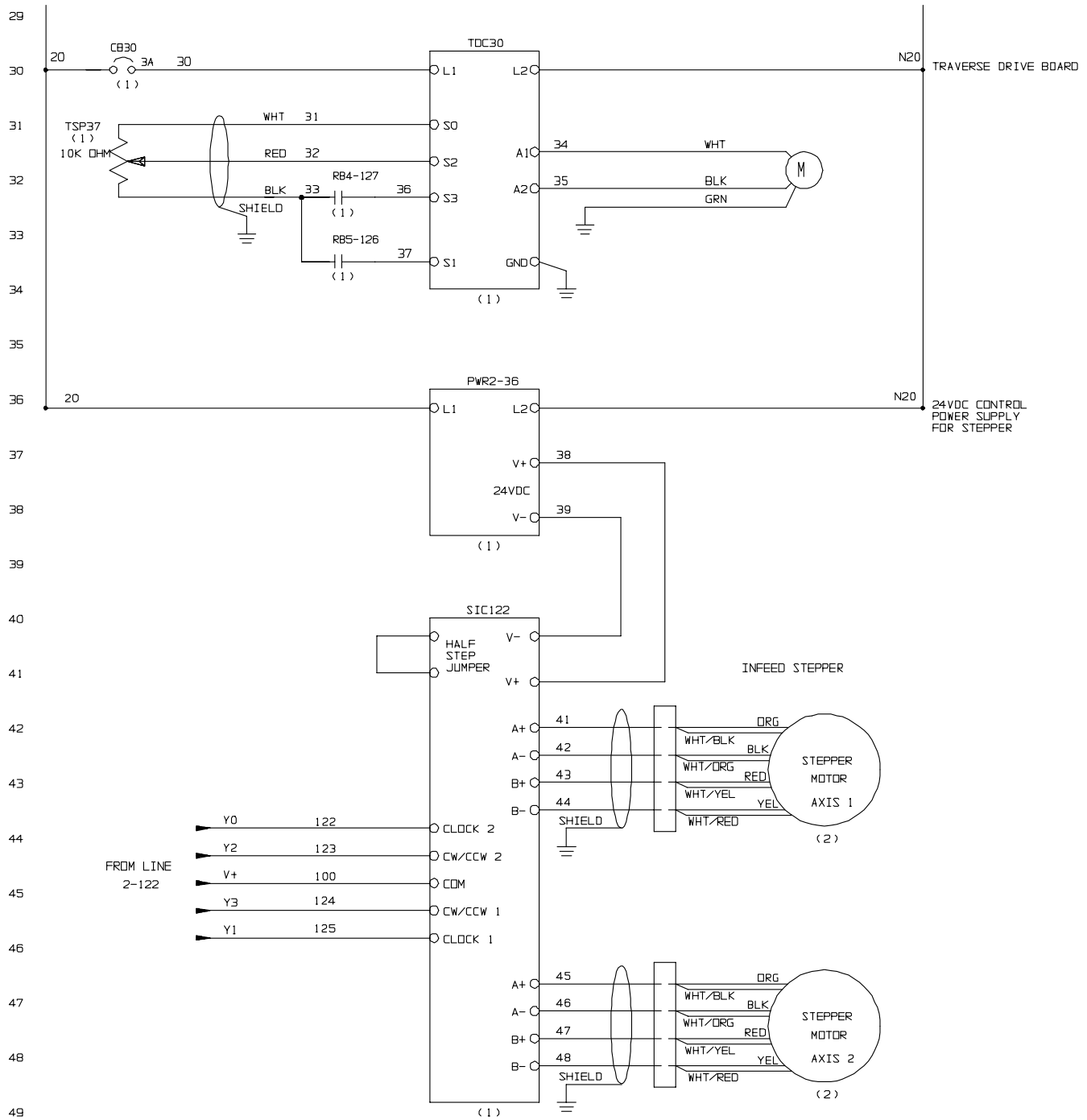

ELECTRICAL TROUBLESHOOTING (Continued)

PROBLEM--AC Main Power Controls: no electrical power to control panel.

Verify all wires shown on the wiring diagram on pages 88 are correct and pull on wire terminals with approximately 3 lbs force to verify there are no loose terminal connections and/or no loose crimps between wire and terminal. If problem persists, test as listed below.

| Possible Cause | Checkout Procedure | |
|--|---|--|
| Emergency Stop Button(ESS) is Depressed | A. Pull Up on ESS Button | Machine works Yes--end troubleshooting No--go to Step B. next |
| You must push the System Start Switch (SSS) to get power to control Panel | B. Listen for the Magnetic Starter (MAG) contacts to pull in with a clunk | Machine works Yes--end troubleshooting No--go to step C. next. |
| Main Power Cord is not plugged in | C. Plug in main power cord | Machine works Yes--end troubleshooting No--go to step D. next. |
| Guard doors must be closed and ALL Switches MUST be turned OFF . | D. Close guard doors and turn off all switches. | Machine works Yes--end troubleshooting No--go to step E. next. |
| Relay Block 3 relay is not powered | E. Check for Red light on in Relay Block 3 (RB3). | Red light is on Yes--Skip to Step M. No-- go to step F. next. |
| No DC Power | F. Check for Green light on in DC Power Supply 1 (PW1). | Green light is on Yes--Go to Step G. next. No-- Skip to step H. |
| PLC is not functioning | G. Check for PLC output light Y7 is on. | Green light on PLC next to Y7 on the PLC is lit. Yes--Replace relay block in RB3 No--Contact factory - PLC problem. |
| Main 15 amp outlet circuit breaker has tripped | H. Check circuit breaker in your building and reset if necessary. (Check wall outlet with a light to make sure it works) | Machine works Yes--end troubleshooting No--light works in outlet--go to Step I. No-- light does not work in outlet. You must solve your power delivery problem independent of machine. |
| No 120 Volts AC power to Filter (FTR) | I. Check for 120V at Cord into FTR (Power Cord #32) | FTR "Line" Terminals for 120 Volts AC Yes--Go to Step J. next. No--Replace Power Cord |
| No 120 Volts AC power out of Filter | J. Check for 120V out of FTR | FTR "Load" Terminals for 120 Volts AC Yes--Go to Step K. next. No--Replace Filter |
| No 120 Volts AC power to Main Circuit Breaker (MCB) | K. Check for 120V to MCB | MCB left terminal (01MCB--) to Neutral (Blue) term on FTR for 120 volts AC Yes--Go to Step L. next. No--Check wires (#01), replace if bad |

ELECTRICAL TROUBLESHOOTING (Continued)

| <u>Possible Causes</u> | <u>Checkout Procedure</u> | |
|---|--|---|
| No 120 Volts AC power from Main Circuit Breaker (MCB) | <p>L. Check for 120V from MCB</p> <p>M. Check for 120 Volts AC at terminal Block 27.</p> | <p>MCB right terminal (03MCB--) to Neutral (Blue) Terminal on FTR for 120 Volts AC Yes--Go to Step M. next. No--Flip Switch on MCB to "ON" - Machine works-- end trouble shooting Machine does not work-- replace MCB</p> <p>Measure 120 volts AC from Terminal Block 27 (05TBG27) to the Neutral (Blue) Terminal on FTR Yes--Go to Step N. next. No--Check wire # 05. Verify Jumpers on grey Terminal Blocks 1-3.</p> |
| Grind Motor Switch not working | N. Check for 120 Volts AC at Grind Motor Switch (GMS) Terminals 3 | <p>Measure 120 volts AC from GMS Terminal 3 (82GMS-3) to the Neutral (Blue) Terminal on FTR Yes--Go to Step O. next. No--Flip Switch and check again- Works--Switch is upside down. Does not work-- Check wiring/Verify continuity of W#78 / Replace Switch if bad</p> |
| System Start Switch not working | O. Hold in green System Start Switch (SSS) and Check voltage out of contact at terminal 4 | <p>Measure 120 Volts AC from (SSS) terminal 4 to the Neutral (Blue) Terminal Block 4 (02TBB-4) Yes--Go to Step P. next No--Check wire #82 for continuity, then verify contact continuity. Replace bad part.</p> |
| Emergency Stop Switch not working | P. Hold in SSS and Check voltage out of contact at terminal 1 of the red Emergency Stop Switch (ESS) MAKE SURE ESS SWITCH IS PULLED UP! | <p>Measure 120 Volts AC from (ESS) terminal 1 to the Neutral (Blue) Terminal Block 4 (02TBB-4) Yes--Go to Step Q. next No--Check wire #81 for continuity, then verify NC contact continuity. Replace bad part.</p> |
| LVR has detected improper voltage or is not functioning | Q. Hold in SSS and Check voltage at Low Voltage Relay (LVR). LVR must be installed in 8-pin socket. | <p>Measure 120 Volts AC from LVR terminal 1 (15LVR-1) to the Neutral (Blue) block 02TBB-4 Yes--Go to Step R. next No--Check for 120 Volts AC from LVR terminal 6 to term 7. Yes--Check light on top of LVR: -Light on top should be steady red. Indicates Relay is energized. Replace LVR if there is red light & voltage at Terminal 8 but not at 1. -Flashing Green indicates Undervoltage trip. -Flashing Red indicates Overvoltage trip. (If light is flashing press reset button located on top of LVR. Light should change to green then steady red.) If flashing after reset is pressed then you must solve your power delivery problem independent of machine. No--Verify wires to LVR terminal 6 & 7.</p> |
| Relay Block 3 relay is not functioning | R. Hold in SSS and Check voltage at Relay Block 3 (RB3) terminal 14. | <p>Measure 120 Volts AC from RB3 terminal 14 to the Neutral (Blue) Terminal Block 4 (02TBB-4) Yes-- Go to Step S. next No--Verify voltage into RB3 terminal 11. Replace relay in RB3 if there is 120 VAC to RB3 terminal 11 but not 14.</p> |
| Mag Starter is bad | S. Hold in SSS and Check voltage at MAG A1 & A2. | <p>Measure 120 Volts AC from MAG Term A1 to Term A2 Yes--MAG Should pull in with clunk, if not replace MAG. No--Verify Continuity of Wires (#13 & 16)</p> |

ELECTRICAL TROUBLESHOOTING (Continued)

PROBLEM--Machine Shuts off 2 seconds after you turn on Grind Motor Switch.

Possible Cause

Checkout Procedure

Low Voltage

A. Remove electrical box cover and watch LVR light on top of LVR

-Light on top should be steady red. Indicates Relay is energized. If the light turns off then comes back green then red this means the sensor has detected a trip mode and restarted. (It is tripping under load and the unloaded power is not outside the range. This is a power delivery problem independent of machine. Make sure there is no other equipment on the circuit and that the correct size wire was used for the outlet.)
-Flashing Green indicates Undervoltage trip.
-Flashing Red indicates Overvoltage trip.
(If light is flashing press reset button located on top of LVR. Light should change to green then steady red.) If flashing after reset is pressed then you must solve your power delivery problem independent of machine.

PROBLEM--(MAG) turns on only with System Start Switch held in.

Possible Cause

Checkout Procedure

(MAG) holding contact has failed

A. Check wiring to MAG holding contact in T3 . Verify the magnetic starter holding contact is receiving power.

Measure 120 Volts AC at MAG term T3 to Neutral (Blue) Terminal on FTR for 120 Volts AC.
Yes--Go to Step **B.** next.
No-- Check wiring to MAG T3. Replace wire #07 if necessary.

B. Check continuity of MAG holding contact. **UNPLUG MACHINE.** Remove cover plate on top of MAG. Hold in center of MAG (Blue Area) to manual pull in contact. Check continuity between T3 to L3.

Verify continuity between T3 to L3
Yes-- Check wiring from MAG L3 to Grey Terminal Block 25 wire #17. Then from TBG 25 to SSS Terminal 4 wire #76.
No-- Replace MAG

ELECTRICAL TROUBLESHOOTING (Continued)

PROBLEM-- Grinding Motors Don't turn on when GMS is switched to On.

| <u>Possible Cause</u> | <u>Checkout Procedure</u> | |
|--|---|--|
| Guard Doors are Open | A. Close the front doors | Machine works Yes--end troubleshooting No--go to Step B. next |
| Door Safety Switches are not working properly | B. Check Alignment of Door Safety Switches on doors | Check alignment of door switch. Make adjustments if necessary. Yes--end troubleshooting No--go to Step C. next |
| | C. Check for light on PLC inputs X4 | Light next to X4 is on. Yes--Skip to Step F. No--go to Step D. next |
| | D. Check for 24VDC at the Door Safety Switch. Open Cover on Switch and check voltage with doors Open. | Measure 24VDC from Terminal 13 to 14 on Door safety Switch. Yes--Go to Step E. next No--Check connections and verify continuity of wire 40 to TTB4 & PLC cable. |
| | E. Check for 0 VDC at the Door Safety Switch. Check voltage with doors Closed. | Measure 0 VDC from Terminal 13 to 14 on Door safety Switch when doors are closed. Yes-- X4 should light on PLC - verify wiring and contact factory- PLC issue. No--Recheck door switch alignment. Replace Door Safety Switch. |
| Grind Motor Switch (GMS) is not working properly | F. Check for light on PLC inputs X6 | Light next to X6 is on. Yes--Skip to Step I. No--go to Step G. next |
| | G. Check for 24 VDC into GMS. Remove yellow wire 65 at GMS terminal 5. | Remove wire 65 (65GMS-5) and measure 24 volts DC from wire to the V+ on PW1. Yes--Reinstall wire. Go to Step H. next. No--Verify continuity of wires from TTB. |
| Relay Blocks 1 & 2 are not working properly. | H. Verify Continuity of GMS with power off. | Turn Power off. Verify continuity between terminals on GMS where wire #65 & wire #66 are plugged into. Continuity: Yes-- verify wire #66 at TTB6 & Cable from TTB to PLC, Light X6 should be lit see Step F. , contact factory if not- Issue with PLC No-- replace GMS. |
| | I. Check for red LED light on RB1 & RB2. | Lights on RB1 & RB2 are on. Yes--Go to Step J. next No--Verify there is 24 volts DC from A1 to A2 on RB1 & RB2. Yes-- Replace removable relay. No-- Check continuity of cable from PLC and wire from TTB, verify jumper on A1/A2 side. If only one light is out, check jumper on RB1 to RB2. Replace removable Relay in one with Light out. (To verify it is the removable relay, switch with another relay) |

ELECTRICAL TROUBLESHOOTING (Continued)

| <u>Possible Cause</u> | <u>Checkout Procedure</u> | |
|-----------------------|--|---|
| | J. Check voltage into RB1 and RB2 | Measure 120 volts AC from RB1 terminal 11 to terminal 21 and RB2 terminals 11 to 21 Yes--Go to Step K. next. No--Check wiring/Verify Continuity or wires to RB1 11 & 21 and RB2 11 & 21 |
| | K. Check voltage out of RB1 and RB2 | Measure 120 volts AC from RB1 terminal 14 to terminal 24 and RB2 terminals 14 to 24 Yes--Go to Step K. next. No-- Replace removable Relay block in RB1 or RB2 or both depending on above voltage check. (To verify it is the removable relay, switch with another relay) |
| Bad Grinding motor | K. Remove electrical access panel on grinding motor and check for voltage at the motor. | Measure 120 volts AC at motor terminals from brown incoming wire to blue incoming wire. Yes--Replace Grinding motor No-- Replace Grinding motor cord |

ELECTRICAL TROUBLESHOOTING (Continued)

PROBLEM--Traverse Drive not working in (manual) jog mode

Assuming 115 Volts AC to control panel and all other manual mode functions are working.

| Possible Cause | Checkout Procedure | |
|--|--|--|
| Traverse Speed Pot (TSP) set to zero | A. Set (TSP) to 35 on the control panel | Traverse works Yes--end troubleshooting No--go to step B. next |
| Circuit Breaker 1 (CB1) (3 amp) tripped | B. Press in on CB1 to Reset. Too heavy a grind causes grinding head traverse motor to overload and trip the circuit breaker. | Traverse works Yes--end troubleshooting No--go to Step C. next |
| Traverse Drive Control (TDC) does not have power | C. Check for 120 Volts AC incoming to (TDC). | The Green Power LED on TDC should be lit. Light on--Skip to Step D. Light off-- Measure 120 volts AC from wire #20 at L1 to wire #23 at L2 Yes-- Replace TDC No--Check continuity of wire #20 at L1 and #23 at L2 and CB1 |
| Traverse Direction Switch (TDS) not working | D. Hold in the Traverse Left Button on the control panel. Check for light on PLC inputs X0. (Right Button turns on X1) | Light next to X0 on PLC is: On-- Skip to Step G. Off-- go to Step E. next |
| | E. Check for 24 volts DC into TDS. (Remove yellow wire at TDS terminal 5 and check voltage from wire to power supply) | Measure 24 volts DC from PW1 V+ to wire at TDS terminal 5 (61TDS-5) Yes--go to step F. next No-- Check continuity of wire #61 |
| | F. Hold in the Traverse Left Button on the control panel. Check for 24 volts DC Out of TDS. (Terminal 4 is on the right side of the switch. Use Term 6 for Traversing right.) | Measure 24 volts DC from PW1 V+ to TDS terminal 4 (60TDS-4) Yes--Check continuity of wire#60 from TDS to TTB, and PLC input cable. No-- Check continuity of TDS. |
| Check PLC out signal | J. Hold in the Traverse Left Button on the control panel. Check for light on PLC outputs Y4. (If the Right Traverse Button is held, Y5 should be lit.) | Light is: On-- go to step K. next Off-- Verify that prox is not on. (Lights X2 & X3 should be off on PLC. If on, go to Proximity Switch troubleshooting section.) If X2 or X3 is not on, Contact Factory -- Issue with PLC |
| Bad Relay Block Relay | K. Verify that Relay Block RB5 light comes on when Traverse Left is pressed, and that RB4 light comes on when Traverse Right is pressed | Lights come: On-- go to step L. next Off-- Check for 24 volts DC to A1 to A2 on Relay Block with button held. Yes-- Replace Relay Block No-- Check continuity of wires to A1 (#47) & A2 (PLC Cable) |

ELECTRICAL TROUBLESHOOTING (Continued)

| Possible Cause | Checkout Procedure | |
|---|---|--|
| Bad Relay Block Relay | <p>L. Remove wires at RB4 & RB5 and verify continuity from terminal 11 to term 14 when Relay Block light is on.</p> | <p>Continuity when light is on Yes--Reinstall wires, go to step M. next No-- Replace removable relay</p> |
| (TSP) (10K) is bad | <p>M. Check (TSP) for 10,000 ohms Remove three wires from (TDC) red from term S2 white from term S0 black from inline connector (Wire 39)</p> | <p>Check for 10,000 ohms red to white wire Full CCW--0 ohms Full CW--10,000 ohms Red to black wire Full CCW--10,000 ohms Full CW--0 ohms Yes--go to Step N. next No--replace (TSP)</p> |
| No DC Voltage from (TDC) Traverse Drive Control | <p>N. Check for 90 Volts DC across (TDC) terminals A1 to A2 this voltage drives the DC traverse motor. NOTE: Traverse must be on and have (TSP) turned full CW to maximum voltage of 90 VDC, and Left or Right Direction must be pressed on TDS</p> | <p>Check (TDC) terminals A1 to A2 for 90 Volts DC Yes--go to step O. next No--Replace TDC</p> <p>Note:If voltage is less than 90 VDC verify pots on TDC. See page 24</p> |
| Traverse Motor is bad | <p>O. Check traverse motor continuity</p> | <p>Remove wires from terminals A1 & A2 0 ohms across the black and white wires Yes--Replace motor. No--go to Step N.</p> |
| Worn motor brushes | <p>N. Inspect Motor Brushes</p> | <p>Remove the brushes one at a time and maintain orientation for reinsertion. See if brush is worn short, 3/8" [10 mm] minimum length. Yes--replace motor brushes No--replace Traverse Drive Motor</p> |

ELECTRICAL TROUBLESHOOTING (Continued)

PROBLEM--Traverse Proximity Switches not working in (manual) jog mode
Assuming 115 Volts AC to control panel and all other manual mode functions are working.

| Possible Cause | Checkout Procedure | |
|---|---|--|
| Gap between flag and prox is incorrect. | A. Gap between flag and Prox should be 3/16" to 1/4" [4-6mm]. Prox light does not light when Grinding head is over prox. | If incorrect, adjust per adjustment section of manual. Light on Prox works Yes--Skip to Step D. No-- go to step B. next |
| Proximity switch is bad | B. Disconnect Prox from cable at Prox head and switch with other Prox on machine. | Place metal object in front of Prox. Light on Prox come on. Yes-- Replace bad Prox Head No-- go to step C. next |
| | C. Measure 24 volts DC to Prox cord at TTB | Measure 24 volts DC from Blue terminal to Brown terminal on TTB 3 Yes-- Replace Prox Cord. No-- Verify Jumpers on TTB |
| | D. With Prox light on, the correlating LED on the TTB should be on. | LED on TTB is on Yes--Skip to step F. No--go to step E. next |
| | E. With Prox light on, Measure from the correlating TTB Grey terminal to the Brown term on TTB3 | Measure 24 volts DC from Grey Terminal to Brown Terminal Yes-- Replace TTB No-- Verify Prox head is functioning by switching with other Prox. Replace if bad or replace Prox Cord. |
| | F. Light on PLC X2 for right side and PLC X3 for left side should come on. | Light on PLC comes on Yes--Contact factory - Issue with PLC No--Verify continuity of cable from TTB to PLC. Replace cable or TTB. |

ELECTRICAL TROUBLESHOOTING (Continued)

PROBLEM--Machine exhaust fan does not come on. (Machine must be on)

Possible Cause

Checkout Procedure

Bad Fan cord

A. Remove cord at fan. Check voltage across terminals.

Measure 120 volt AC across terminals at cord plug.

Yes-- Replace Fan

No-- Go to step **B.** next

B. Disconnect Fan cord from fan power cord (two male to female terminals about 2 feet down fan cord.)

Measure 120 volt AC across female terminals at end of cord from electrical box.

Yes-- Replace Fan cord

No-- Replace Fan Power Cord.

Check voltage from cord that goes back to the electrical box

PROBLEM--Machine Light does not come on. (Machine must be on)

Possible Cause

Checkout Procedure

Switch on light must be set to on position

A. Press switch on light to on.

Light works

Yes-- End troubleshooting

No-- Go to step **B.** next

B. Must be plugged into 60 Hz power. (If there is a transformer on this machine it is likely that you are connected to 50 Hz power)

Your machine is connected to 60 Hz power

Yes-- Go to step **C.** next

No-- Replace light with 120 volt 50 Hz light.

C. Replace Light Bulb

Light works

Yes-- End troubleshooting

No-- Go to step **D.** next

D. Open cover on Light. Check incoming voltage from light power cord.

Measure 120 volt AC across end of light power cord from electrical box.

Yes-- Replace light

No-- Replace Light Power Cord.

ELECTRICAL TROUBLESHOOTING (Continued)

PROBLEM--Both Stepper Infeed not working in (manual) jog mode.

Assuming 115 Volts AC to control panel and all other manual (jog) mode functions are working.

| Possible Cause | Checkout Procedure | |
|--|--|--|
| Infeed Jog Switch is not held to on position | A. Hold switch on in either direction | Stepper motor works: Yes--end troubleshooting No--go to Step B. next |
| Actuator is at physical limit | B. Move stepper in opposite direction | Stepper Motor works: Yes--end troubleshooting No--go to step C. next |
| High Low Switch is not on high speed | C. Put switch on high speed (rabbit) for ease of checkout of Stepper Infeed Control (SIC) | High speed works: Yes--end troubleshooting No--go to Step D. next |
| Stepper motor drive coupling is loose | D. You can feel stepper pulses on motor when (HLS) is on high or low & (IJS) switch is depressed in either in or out direction. Check for loose coupling. Retighten coupling to drive infeed screw. | Stepper works: Yes--end troubleshooting No--go to Step E. next |
| 24 Volt Dc Power Supply for steppers not working (PW2) | E. Check for green light on PW2 | Green light is on: Yes-- Skip to step G. No-- go to step F. next |
| | F. Check for 120 Volts AC into PW2 | PW2 terminal L to Terminal N for 120 Volts AC Yes-- go to step G. next No-- Check wires #27 & #43 |
| | G. Check for 24 Volts DC into Stepper Infeed Controller (SIC) | Remove green power plug into SIC. Measure 24 Volts DC from top terminal to bottom terminal for plug. NOTE: SIC is power sensitive, Yellow V- wire must be installed in top terminal and Red V+ must be in bottom terminal. Yes-- Reinstall plug. go to step H. No-- Replace PW2. |
| Infeed Jog Switch (IJS) not working | H. Press and hold Stepper infeed "In" button. Check for light on PLC next to XA. (X9 is the light indicates "Out" button is pressed.) | Light on PLC is on: Yes-- Skip to step K. No-- go to step I. next |
| | I. Check for 24 Volts DC into IJS. Remove yellow wire #70 at IJS and measure to V+ on PW1 | Measure 24 volts DC from yellow wire 70IJS-5 to V+ on PW1 Yes-- go to step J. next No-- Check continuity of wire #70 |

Possible Cause

Checkout Procedure

| | | |
|--|--|--|
| <p>No signal from Infeed Motor Selector Switch</p> | <p>J. Remove wire #70 on Terminal 5 and Wire #71 on Terminal 6. Press and hold IJS "In" button and check continuity of Terminal 5 to Term 6.</p> <p>K. With Infeed Motor Selector (IMS) set to infeed both motors (center position) Check for PLC lights next to XB (Top) and XC (bottom).</p> | <p>Continuity from Terminal 5 to Terminal 6: Yes--Reinstall wires. Check continuity of Wire #71, TTB10 and PLC inputs Cable. Contact factory - Issue with PLC. No--Replace IJS</p> <p>Light XB and XC on: Yes--Contact Factory -- issue with PLC or Stepper Drive (SIC) No-- Check continuity of Wires #72, 73, 74, 75 and of Contacts on IMS.</p> |
|--|--|--|

**PROBLEM--Only One Stepper Infeed is working in (manual) jog mode.
 Assuming 115 Volts AC to control panel and all other manual (jog) mode functions are working.**

Possible Cause

Checkout Procedure

| | | |
|--|--|--|
| <p>Infeed Motor Selector Switch (IMS) in wrong position.</p> | <p>A. Move IMS to center position.</p> | <p>Both Stepper motors work: Yes--end troubleshooting No--go to Step B. next</p> |
| <p>No signal to PLC</p> | <p>B. Check for PLC lights next to XB (Top) and XC (bottom).</p> <p>C. Switch Infeed motor connections to Stepper Infeed Controller (SIC). Note: Green Plug from on SIC can be removed by pulling straight away from SIC. You do not need to take the wires out of the plug.</p> | <p>Light XB and XC on: Yes--go to Step C. next No-- Check continuity of Wires #72, 73, 74, 75 and of Contacts on IMS.</p> <p>Same infeed stepper motor works and other one still does not work: Yes--Bad Stepper motor or Cord. Remove bad stepper motor and verify that it does not work but plugging into the connection at the good stepper motor. If motor works, then replace cord. If motor does not work, replace motor No--Contact Factory, issue with Stepper Infeed Controller or PLC</p> |

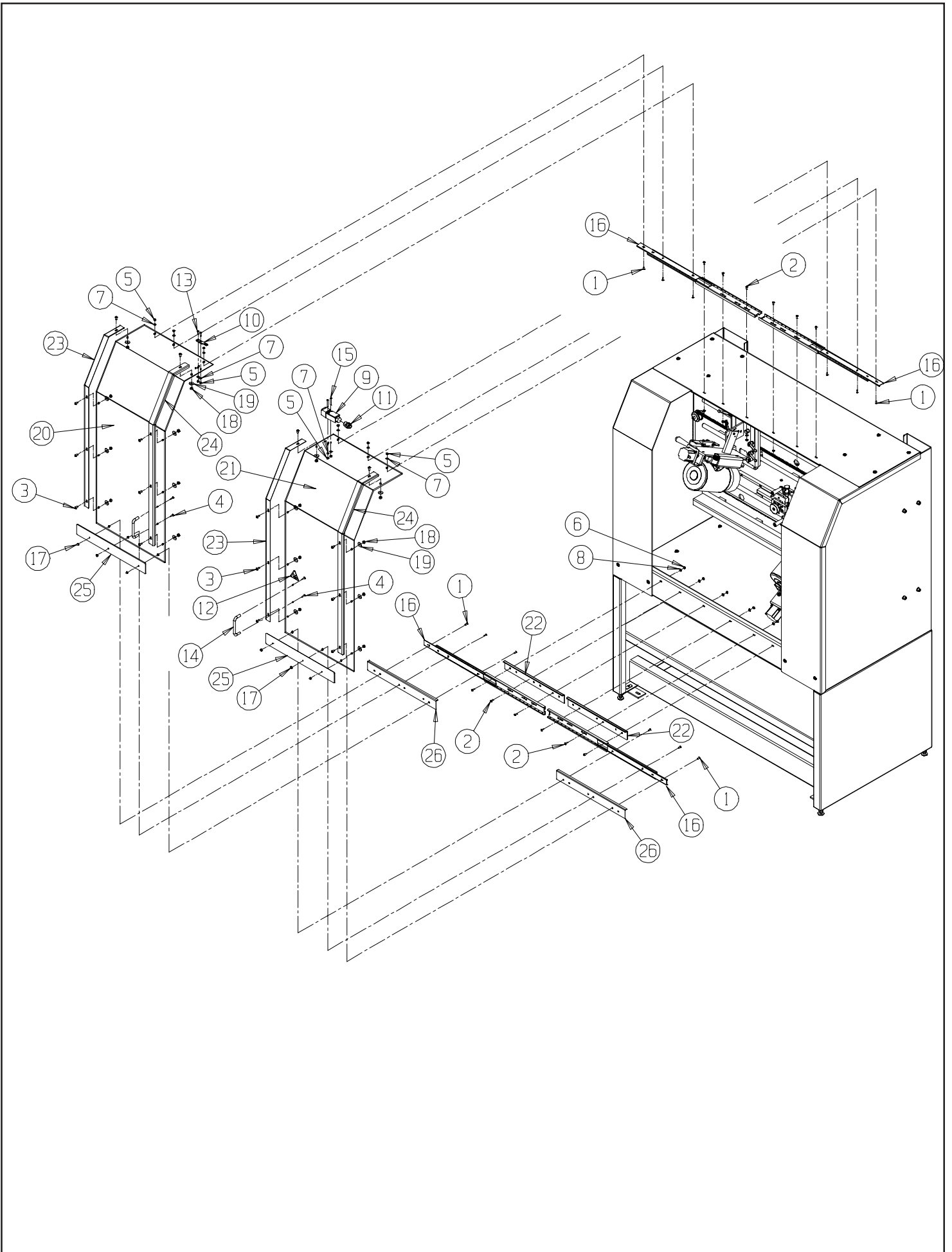

| <u>DIAGRAM NUMBER</u> | <u>PART NUMBER</u> | <u>DESCRIPTION</u> |
|---------------------------|------------------------|---|
| 1 | B160807 | 8-32 x 1/2" Long Button Head Socket Cap Screw |
| 2 | B190813 | 10-24 x 1/2" Long Button Head Socket Cap Screw |
| 3 | B250816 | 1/4-20 x 1/2" Long Button Head Socket Cap Screw |
| 4 | D161266 | 8 x 3/4" Long Pan Head Machine Screw |
| 5 | J167000 | 8-32 Locknut Jam with Nylon Insert |
| 6 | J197000 | 10-24 Locknut Jam with Nylon Insert |
| 7 | K160001 | #8 Flat Washer SAE |
| 8 | K190001 | #10 Flat Washer SAE |
| 9 | 3707129 | Safety Interlock Switch |
| 10 | 3707372 | Safety Interlock Switch Key |
| 11 | 3707563 | Liquid Tight Strain Relief (for Wire Dia .27-.46) |
| 12 | 3708458 | Sharp Warning Decal |
| 13 | 3708819 | 8-32 x 3/4" Long Button Head Safety Screw * |
| 14 | 3708857 | Black Pull Handle |
| 15 | 3708865 | 8-32 x 1 1/2" Long Button Head Safety Screw * |
| 16 | 3708918 | Door Track Slide (2 Pack) |
| 17 | 3708925 | 8-32 Acorn Nut - Self Locking |
| 18 | 3708926 | 1/4-20 Hex Nut - Center locking |
| 19 | 3708927 | Flat Washer - .5 OD x .27 ID x .032 Thick |
| 20 | 4609064 | Left Side Guard Door |
| 21 | 4609065 | Right Side Guard Door |
| 22 | 4609075 | Door Side Spacer Plate |
| 23 | 4609076 | Left Side Window Brace |
| 24 | 4609077 | Right Side Window Brace |
| 25 | 4609078 | Door Slide Cover Plate |
| 26 | 4609109 | Door Track Shield |

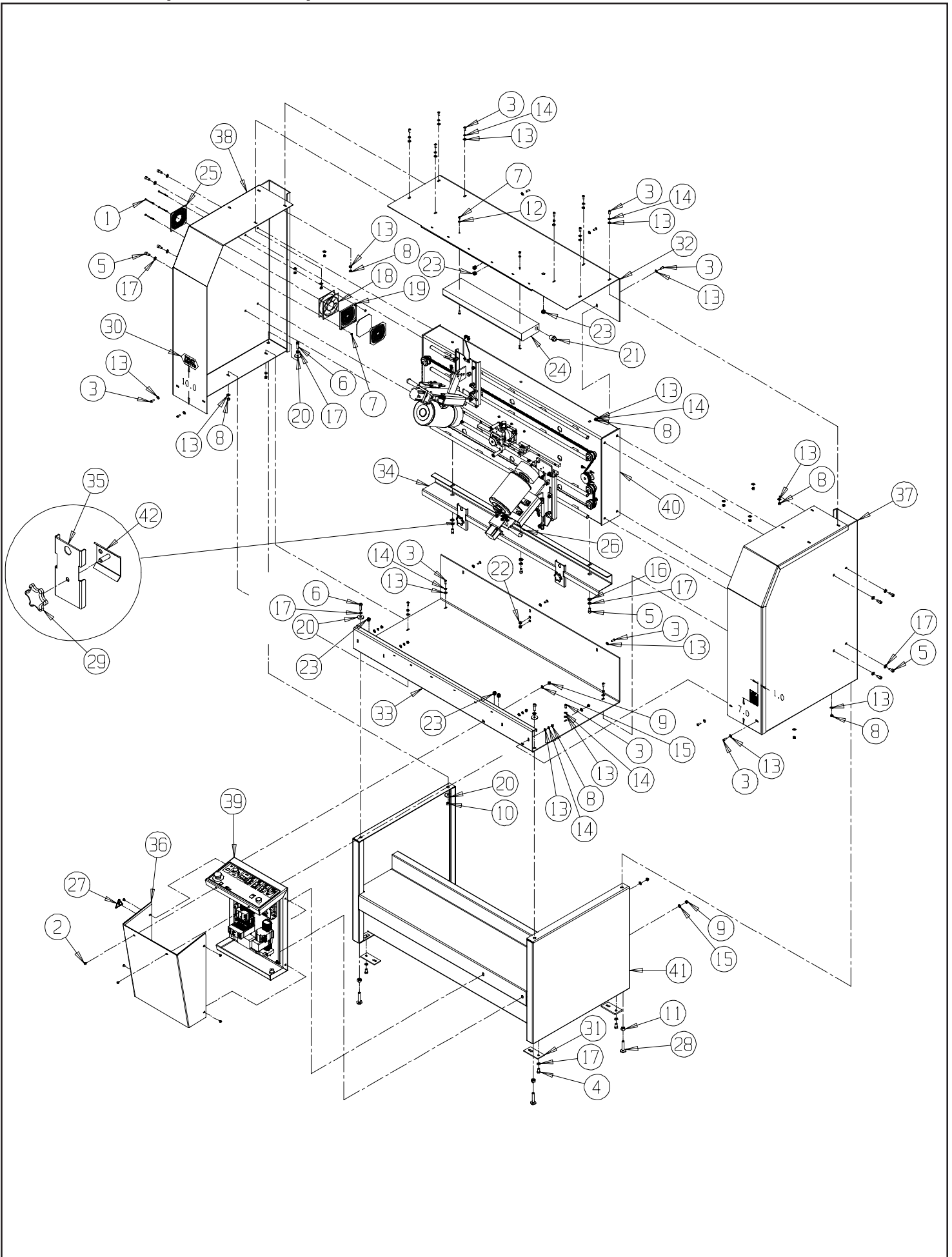

PARTS LIST (Continued)

4609515 CABINET ASSEMBLY

| <u>DIAGRAM NUMBER</u> | <u>PART NUMBER</u> | <u>DESCRIPTION</u> |
|-----------------------|--------------------|---|
| 1 | B164005 | 8-32 x 2 1/2" Long Flat Head Socket Cap Screw |
| 2 | B250816 | 1/4-20 x 1/2" Long Button Head Socket Cap Screw |
| 3 | B251216 | 1/4-20 x 3/4" Long Button Head Socket Cap Screw |
| 4 | B371201 | 3/8-16 x 3/4" Long Hex Head Screw |
| 5 | B371211 | 3/8-16 x 3/4" Long Socket Head Cap Screw |
| 6 | B372011 | 3/8-16 x 1 1/4" Long Socket Head Cap Screw |
| 7 | J167000 | 8-32 Locknut Jam with Nylon Insert |
| 8 | J251000 | 1/4-20 Hex Nut |
| 9 | J317000 | 5/16-18 Locknut Jam with Nylon Insert |
| 10 | J371000 | 3/8-16 Hex Nut |
| 11 | J501000 | 1/2-13 Hex Nut |
| 12 | K160001 | #8 Flat Washer SAE |
| 13 | K250001 | 1/4 Flat Washer SAE |
| 14 | K251501 | 1/4 Split Lockwasher |
| 15 | K310001 | 5/16 Flat Washer SAE |
| 16 | K370001 | 3/8 Flat Washer SAE |
| 17 | K371501 | 3/8 Split Lockwasher |
| 18 | 3707689 | Square Axial Fan |
| 19 | 09902 | Filter Guard Assembly for Fan |
| 19a | 3707714 | Filter (5 pack) |
| 20 | 3589106 | Flat Washer - 1.4 OD x .4 ID x .13 Thick |
| 21 | 3707049 | Liquid Tight Strain Relief (for Wire Dia .23-.39) |
| 22 | 3707066 | Strain Relief - Push in (for Wire Dia .22-.25) |
| 23 | 3707273 | Strain Relief - Push in (for Wire Dia .33-.36) |
| 24 | 3707687 | 24" Fluorescent Light (60Hz 120VAC - only) |
| 24a | 3707717 | Flourescent Bulb |
| 25 | 3707696 | Fan Guard |
| 26 | 3708046 | Rubber Gromet |
| 27 | 3708448 | Electrical Warning Decal |
| 28 | 3709563 | Adjustable Leveling Bolt |
| 29 | 3709613 | Star Knob 5/16-18 Female Threaded |
| 30 | 3709926 | Foley United Decal |
| 31 | 3889068 | Anchor Strap |
| 32 | 4609056 | Frame Top Panel |
| 33 | 4609057 | Frame Bottom Panel |
| 34 | 4609066 | Proximity Bracket Mounting Panel |
| 35 | 4609067 | Proximity Bracket |
| 36 | 4609081 | Control Panel Cover |
| 37 | 4609502 | Frame Side Weldment - Right |
| 38 | 4609503 | Frame Side Weldment - Left |
| 39 | 4609511 | Control Panel Assembly (see page 46) |
| 40 | 4609514 | Traverse Assembly (see page 40) |
| 41 | 4609560 | Frame Base Let Weldment |
| 42 | 6009572 | Proximity Rail Clamp Weldment |
| | 4609097 | Stepper motor Cord |
| | 4609107 | Proximity Sensor Cord -Left |
| | 4609108 | Proximity Sensor Cord -Right |
| | 3707601 | Proximity Sensor |

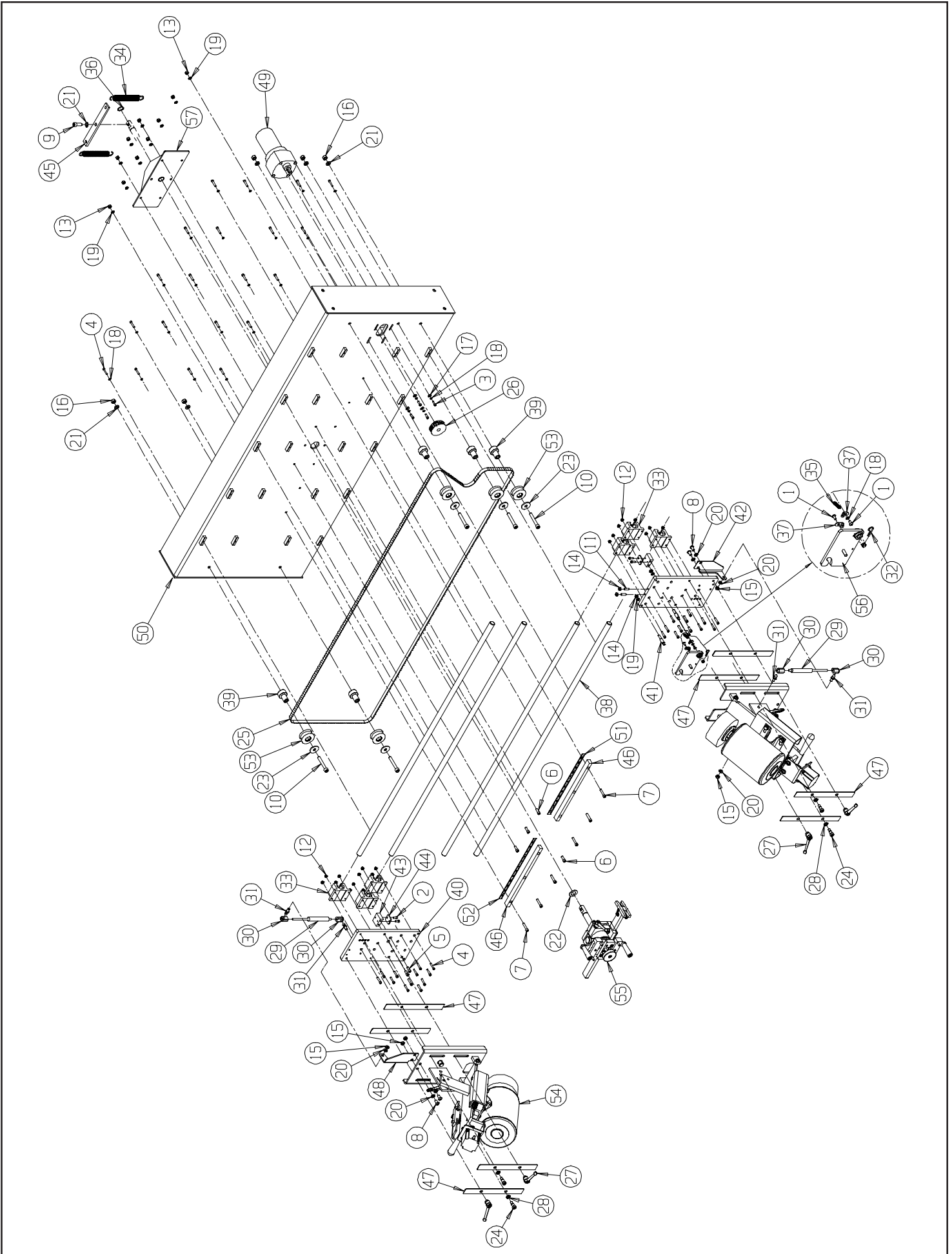

PARTS LIST (Continued)

4609514 TRAVERSE ASSEMBLY

| <u>DIAGRAM NUMBER</u> | <u>PART NUMBER</u> | <u>DESCRIPTION</u> |
|-----------------------|--------------------|--|
| 1 | B190613 | 10-24 x 3/8" Long Button Head Socket Cap Screw |
| 2 | B190811 | 10-24 x 1/2" Long Socket Head Cap Screw |
| 3 | B191031 | 10-32 x 5/8" Long Socket Head Cap Screw |
| 4 | B191611 | 10-24 x 1" Long Socket Head Cap Screw |
| 5 | B251011 | 1/4-20 x 5/8" Long Socket Head Cap Screw |
| 6 | B251211 | 1/4-20 x 3/4" Long Socket Head Cap Screw |
| 7 | B252011 | 1/4-20 x 1 1/4" Long Socket Head Cap Screw |
| 8 | B311013 | 5/16-18 x 5/8 Long Button Head Socket Cap Screw |
| 9 | B371611 | 3/8-16 x 1" Long Socket Head Cap Screw |
| 10 | B374011 | 3/8-16 x 2 1/2" Long Socket Head Cap Screw |
| 11 | C251020 | 1/4-20 x 5/8" Long Cup Point Socket Head Set Screw |
| 12 | J197000 | 10-24 Locknut Jam with Nylon Insert |
| 13 | J251000 | 1/4-20 Hex Nut |
| 14 | J252000 | 1/4-20 Jam Hex Nut |
| 15 | J312000 | 5/16-18 Jam Hex Nut |
| 16 | J371000 | 3/8-16 Hex Nut |
| 17 | K190001 | #10 Flat Washer SAE |
| 18 | K191501 | #10 Split Lockwasher |
| 19 | K251501 | 1/4 Split Lockwasher |
| 20 | K311501 | 5/16 Split Lockwasher |
| 21 | K371501 | 3/8 Split Lockwasher |
| 22 | 80355 | Thrust Washer 1.25 OD x .75 ID |
| 23 | 3589106 | Flat Washer - 1.38 OD x .39 ID x .13 Thick |
| 24 | 3708158 | 3/8 x 1/2" Long Shoulder Bolt |
| 25 | 3708896 | Cog Belt |
| 26 | 3708898 | Cog Drive Pulley |
| 27 | 3708908 | 3/8-16 x 7/8" Long Adjustable Handle |
| 28 | 3708913 | Wave Spring .56 OD |
| 29 | 3708915 | Gas Spring |
| 30 | 3708916 | 10mm Ball Socket |
| 31 | 3708917 | 10mm ball stud w/ 5/16-18 x .55 long thread |
| 32 | 3708931 | Hairpin |
| 33 | 3708932 | Linear Bearing 3/4" Shaft |
| 34 | 3708933 | Extension Spring .84OD x 6" Long |
| 35 | 3708935 | Extension Spring .44OD x 1.5" Long |
| 36 | 3709331 | External Retaining Ring for 3/4" Shaft |
| 37 | 3929040 | Spring Clip |
| 38 | 4609005 | Traverse Shaft |
| 39 | 4609007 | Pulley Shaft |
| 40 | 4609009 | Carriage Base Plate |
| 41 | 4609020 | Pivot Shaft |
| 42 | 4609023 | Bottom Gas Spring Bracket |
| 43 | 4609024 | Belt Clamp Block |
| 44 | 4609025 | Belt Clamp Plate |
| 45 | 4609053 | Spring Bar |
| 46 | 4609054 | Anti-rotate Bar |
| 47 | 4609071 | Vertical Slide/Cover Plate |
| 48 | 4609087 | Top Gas Spring Bracket |
| 49 | 4609100 | Traverse Motor Assembly |
| 50 | 4609101 | Main Base Machined |
| 51 | 4609111 | Scale Decal - Right Side |
| 52 | 4609112 | Scale Decal - Left Side |
| 53 | 4609508 | Idler Pulley Assembly |
| 54 | 4609510 | Grinding Head Assembly (see page 42) |
| 55 | 4609513 | Center Support Assembly (see page 44) |
| 56 | 4609521 | Cam Plate Assembly |
| 57 | 4609541 | Base Support Assembly |

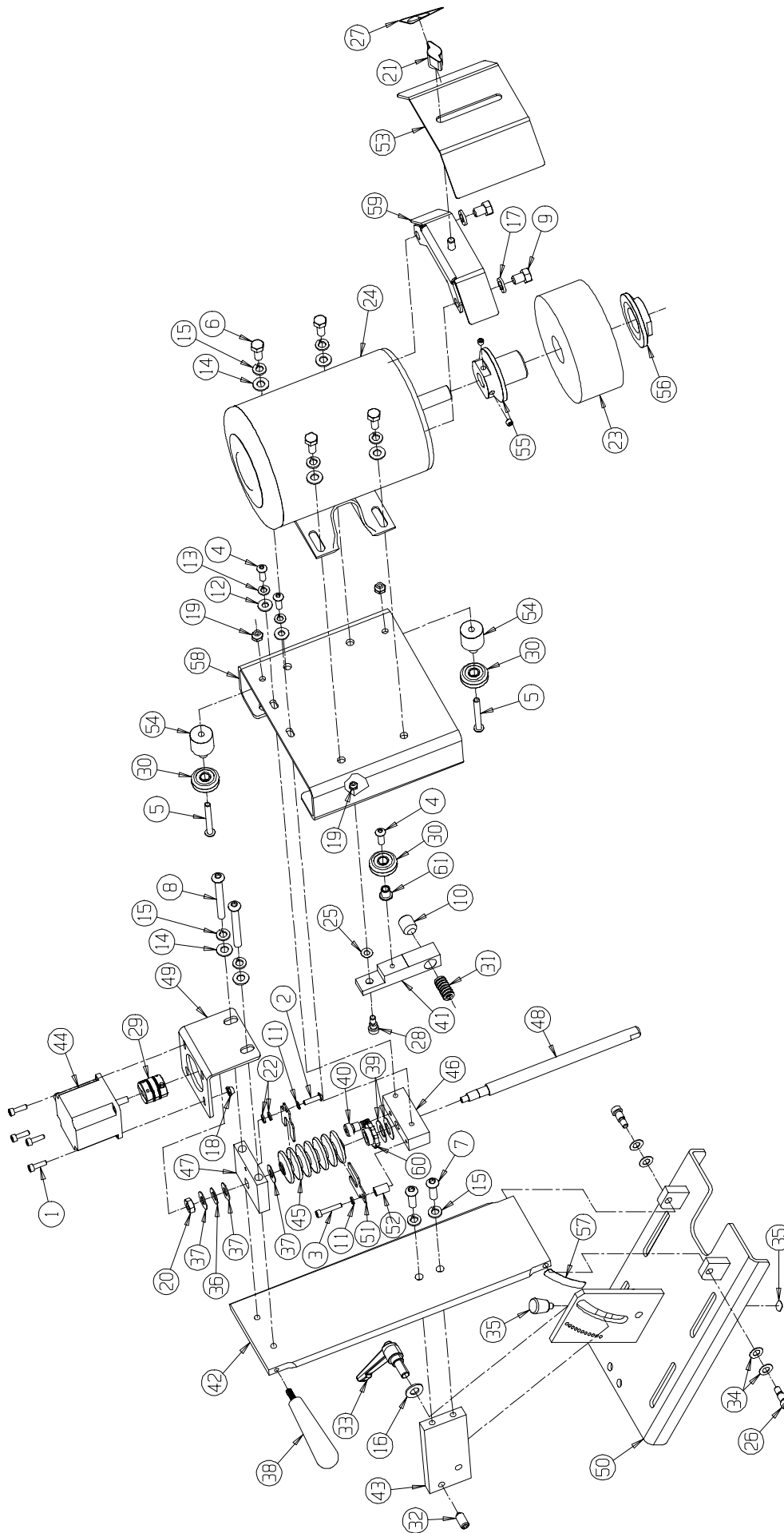

PARTS LIST (Continued)

4609510 GRINDING HEAD ASSEMBLY

| <u>DIAGRAM NUMBER</u> | <u>PART NUMBER</u> | <u>DESCRIPTION</u> |
|-----------------------|--------------------|---|
| 1 | B191011 | 10-24 x 5/8" Long Socket Head Cap Screw |
| 2 | B191213 | 10-24 x 3/4" Long Button Head Socket Cap Screw |
| 3 | B191611 | 10-24 x 1" Long Socket Head Cap Screw |
| 4 | B251216 | 1/4-20 x 3/4" Long Button Head Socket Cap Screw |
| 5 | B253216 | 1/4-20 x 2" Long Button Head Socket Cap Screw |
| 6 | B311201 | 5/16-18 x 3/4" Long Hex Head Cap Screw |
| 7 | B311613 | 5/16-18 x 1" Long Button Head Socket Cap Screw |
| 8 | B311413 | 5/16-18 x 2.75" Long Button Head Socket Cap Screw |
| 9 | B370801 | 3/8-16 x 1/2" Long Hex Head Cap Screw |
| 10 | C621060 | 5/8-18 x 5/8" Long Socket Head Set Screw |
| 11 | K191501 | #10 1/4 Split Lockwasher |
| 12 | K250001 | 1/4 Flat Washer SAE |
| 13 | K251501 | 1/4 Split Lockwasher |
| 14 | K310001 | 5/16 Flat Washer SAE |
| 15 | K311501 | 5/16 Split Lockwasher |
| 16 | K370101 | 3/8 Heavy Flat Washer |
| 17 | K371501 | 3/8 Split Lockwasher |
| 18 | J197000 | 10-24 Locknut Jam with Nylon Insert |
| 19 | J257000 | 1/4-20 Locknut Jam with Nylon Insert |
| 20 | J377000 | 3/8-16 Locknut Jam with Nylon Insert |
| 21 | 80169 | 2-Prong Knob - 5/16-18 Female |
| 22 | 3589127 | Spacer Washer .37 OD x .19 ID x .06 Thick |
| 23 | 3700046 | Straight Cup Grinding Wheel - 5 x 2 x 1.25 Bore |
| 24 | 3707960 | 1/2 HP Motor |
| 25 | 3708103 | Conical Washer .50 OD x .26 ID x .02 Thick |
| 26 | 3708425 | Shoulder Bolt 5/16 Dia. x 3/8 Long |
| 27 | 3708461 | 3600 RPM Warning Decal |
| 28 | 3708543 | Shoulder Bolt .5/16 Dia. x 5/16 Long |
| 29 | 3708629 | Flex Coupling - 1 x 1 x .25 Bore |
| 30 | 3708657 | Dual Vee Roller |
| 31 | 3708658 | Compression Spring |
| 32 | 3708907 | 3/8-16 Stubby Spring Plunger |
| 33 | 3708908 | 3/8-16 x .78" Long Adjustable Handle |
| 34 | 3708912 | Conical Washer .63 OD x .23 ID x .02 Thick |
| 35 | 3708914 | Spring loaded Plunger |
| 36 | 3709062 | Conical Washer .75 OD x .38 ID x .04 Thick |
| 37 | 3709304 | Thrust Washer .81 OD x .38 ID x .03 Thick |
| 38 | 3709384 | 1/4-20 x 3/4" Long Knob |
| 39 | 3709620 | Conical Washer 1.0 OD x .51 ID x .04 Thick |
| 40 | 3709809 | Shoulder Bolt 3/8 Dia. x 3/8 Long |
| 41 | 4609011 | Roller Pivot Arm |
| 42 | 4609012 | V Roller Plate |
| 43 | 4609013 | Angle Clamp Plate |
| 44 | 4609014 | Stepper Motor Assembly |
| 45 | 4609015 | 460 Boot |
| 46 | 4609016 | Infeed Screw Block |
| 47 | 4609017 | Infeed Shaft Support Block |
| 48 | 4609018 | Infeed Left Hand ACME Shaft |
| 49 | 4609019 | Motor Mount Bracket |
| 50 | 4609027 | Adjustable Base Plate |
| 51 | 4609033 | Boot Retainer |
| 52 | 4609043 | Spacer - .20 x .375 x .62 Long |
| 53 | 4609048 | Spact Guard Cover |
| 54 | 4609069 | V Roller Bushing - 1.46 Long |
| 55 | 4609084 | Grinding Wheel Adapter |
| 56 | 4609085 | Grinding Wheel Flange |
| 57 | 4609086 | Grind Angle Decal |
| 58 | 4609504 | Motor/Bearing Plate Weldment |
| 59 | 4609570 | Spark Guard Bracket Weldment |
| 60 | 6009024 | 1/2-10 ACME Backlash Nut |
| 61 | 6609028 | V Roller Short Bushing |

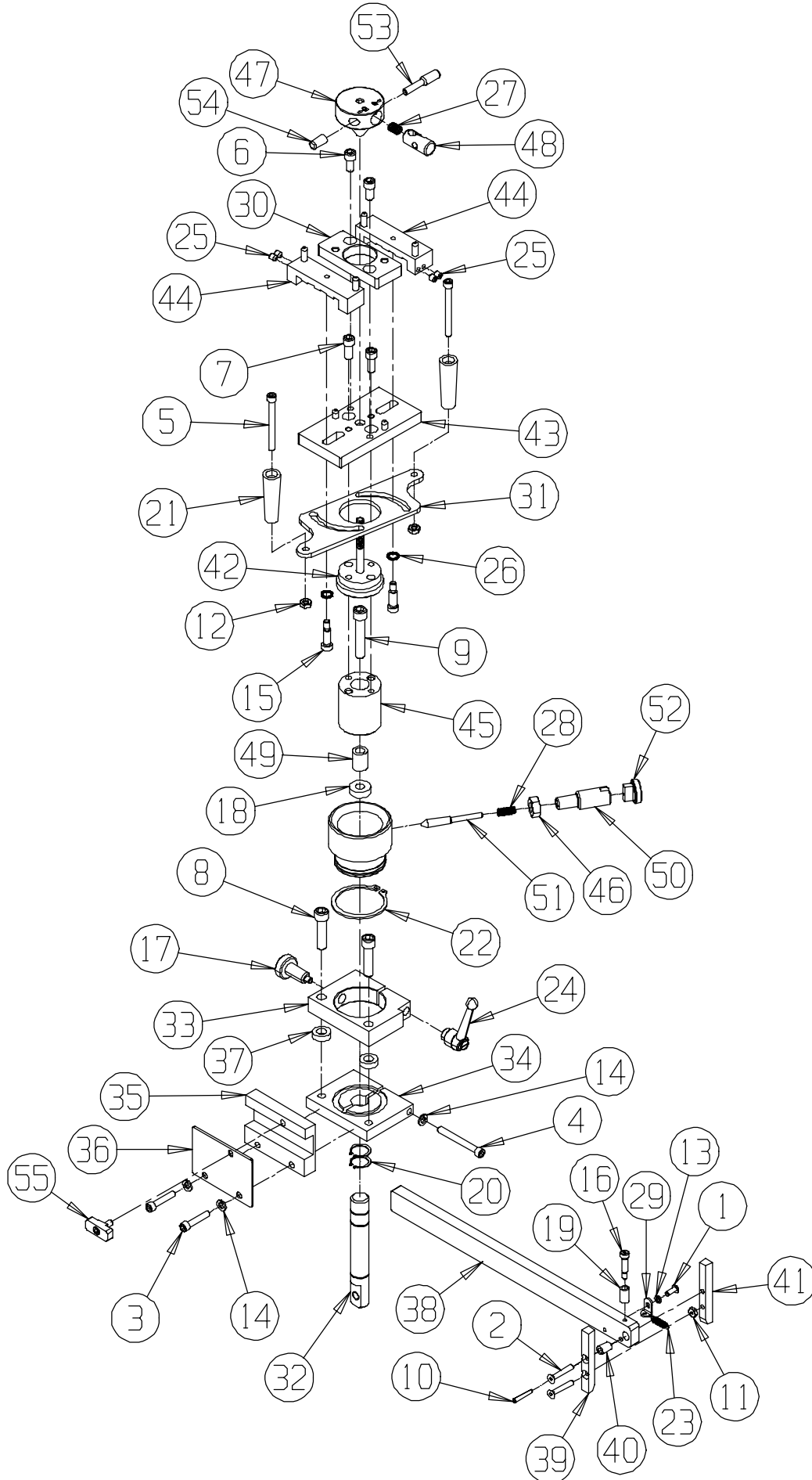

PARTS LIST (Continued)

4609513 CENTER SUPPORT ASSEMBLY

| <u>DIAGRAM NUMBER</u> | <u>PART NUMBER</u> | <u>DESCRIPTION</u> |
|-----------------------|--------------------|--|
| 1 | B190813 | 10-24 x 1/2" Long Button Head Socket Cap Screw |
| 2 | B192005 | 10-24 X 1 1/4" Long Flat Head Socket Cap Screw |
| 3 | B252011 | 1/4-20 x 1 1/4" Long Socket Head Cap Screw |
| 4 | B253611 | 1/4-20 x 2 1/4" Long Socket Head Cap Screw |
| 5 | B254011 | 1/4-20 x 2 1/2" Long Socket Head Cap Screw |
| 6 | B311011 | 5/16-18 x 5/8" Long Socket Head Cap Screw |
| 7 | B311211 | 5/16-18 x 3/4" Long Socket Head Cap Screw |
| 8 | B372411 | 3/8-16 x 1 1/2" Long Socket Head Cap Screw |
| 9 | B373211 | 3/8-16 x 2" Long Socket Head Cap Screw |
| 10 | H191602 | 3/16 x 1" Long Roll Pin |
| 11 | J191000 | 10-24 Hex Nut |
| 12 | J257000 | 1/4-20 Locknut Jam with Nylon Insert |
| 13 | K191501 | #10 Split Lockwasher |
| 14 | K251501 | 1/4 Split Lockwasher |
| 15 | 09528 | Shoulder Bolt 5/16 Dia x 3/4" Long |
| 16 | 3708453 | Shoulder Bolt 1/4 Dia x 3/4" Long |
| 17 | 3708909 | 1/2-13 Spring Plunger |
| 18 | 3708922 | Ball Bearing - 7/8 OD x 3/8 ID |
| 19 | 3708923 | Drill Bushing 3/8 OD x 1/4 ID x 5/8 Long |
| 20 | 3709331 | External Retaining Ring |
| 21 | 3709370 | Handle |
| 22 | 3708924 | External Retaining Ring |
| 23 | 3708928 | Extension Spring .25 OD x 1.12 Long |
| 24 | 3708929 | 5/16-18 x 1.97 Long Adjustable Handle |
| 25 | 3708930 | 1/4-20 x 1/2" Long Brass Tipped Set Screw |
| 26 | 3708934 | Wave Spring |
| 27 | 3708936 | Compression Spring |
| 28 | 3708949 | Compression Spring .295 OD |
| 29 | 3929040 | Spring Clip |
| 30 | 4609032 | Blade Center Mount |
| 31 | 4609034 | Cam Plate Clamp |
| 32 | 4609041 | Pivot Shaft |
| 33 | 4609044 | Balancer Lock Clamp Plate |
| 34 | 4609045 | Pivot Shaft Clamp Plate |
| 35 | 4609046 | Rotate Bar Clamp |
| 36 | 4609047 | Clamp Plate |
| 37 | 4609049 | Spacer .41 ID x .75 OD x .125 Long |
| 38 | 4609050 | Relief Rotate Bar |
| 39 | 4609051 | Release Bar - with Countersink |
| 40 | 4609052 | Spacer .22 ID x .375 OD x .50 Long |
| 41 | 4609072 | Release Bar - Tapped |
| 42 | 4609530 | Center Shaft Assembly |
| 43 | 4609531 | Clamp Slide Plate Assembly |
| 44 | 4609535 | Blade Clamp Block Assembly |
| 45 | 4609536 | Balancer Bearing Assembly |
| 46 | J502000 | 1/2-13 Hex Jam Nut |
| 47 | 4609055 | Center Cone |
| 48 | 4609088 | Center Pin |
| 49 | 4609089 | Bearing Spacer |
| 50 | 4609090 | Alignment Pin Body |
| 51 | 4609091 | Balance Lock Pin |
| 52 | 4609092 | Balancer Lock Knob |
| 53 | 4609113 | Center Knob Lock Pin |
| 54 | 4609114 | Center Knob Lock Pin Nut |
| 55 | 4609580 | 1/4-20 x 1/2 Long Knob Assembly |

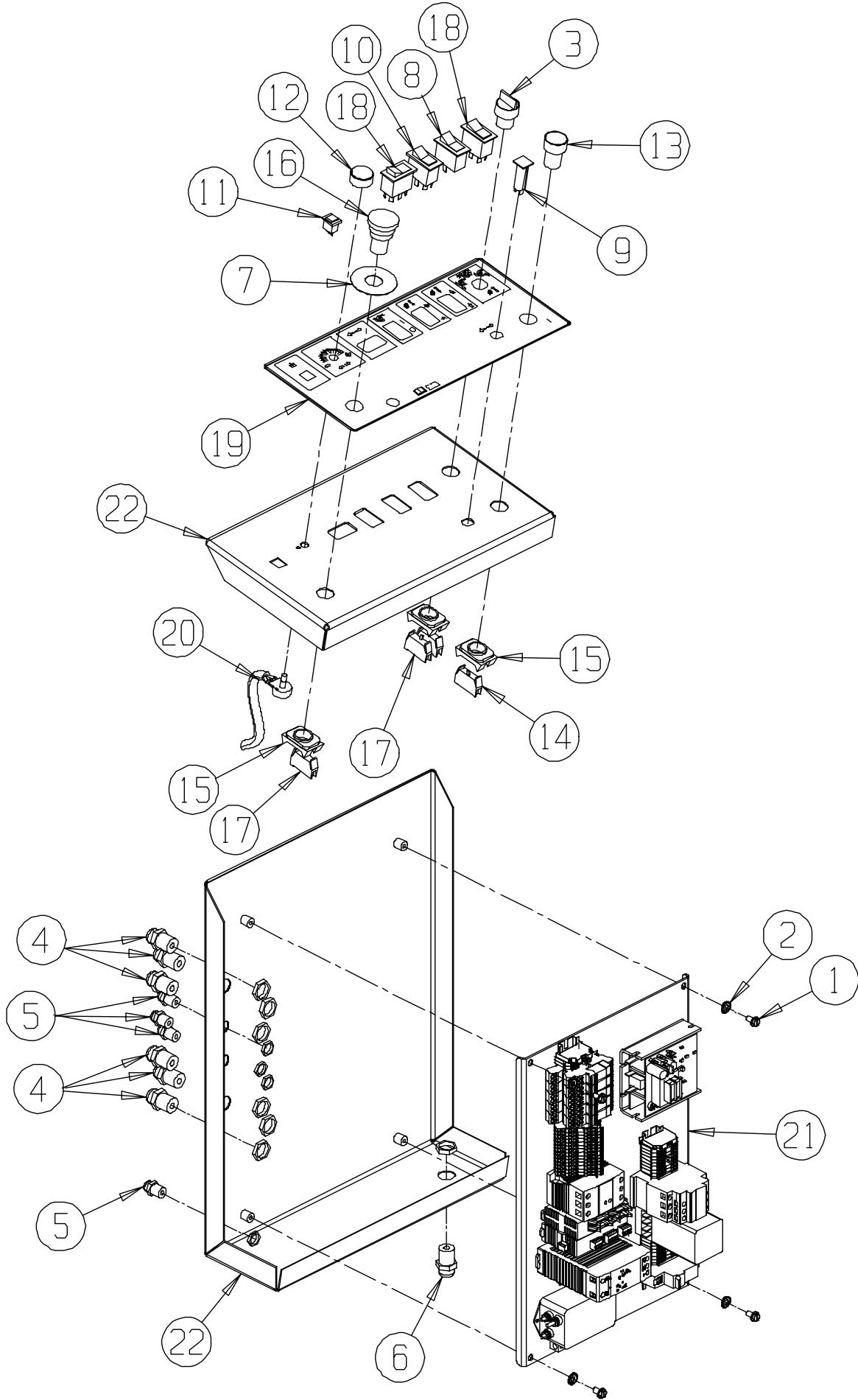

| <u>DIAGRAM NUMBER</u> | <u>PART NUMBER</u> | <u>DESCRIPTION</u> |
|---------------------------|------------------------|--|
| 1 | B250800 | 1/4-20 x 1/2" Long Thread Cutting Screw |
| 2 | R000536 | 1/4 Lock Washer |
| 3 | 80367 | 3 Position Selector Switch |
| 4 | 3707009 | Liquid Tight Strain Relief (for Wire Dia. .27 - .47) |
| 5 | 3707029 | Liquid Tight Strain Relief (for Wire Dia. .19 - .30) |
| 6 | 3707093 | Liquid Tight Strain Relief (for Wire Dia. .43 - .55) |
| 7 | 3707342 | Yellow Emergency Stop Ring |
| 8 | 3707367 | ON/OFF Rocker Switch (DPST) |
| 9 | 3707399 | 3 Amp Circuit Breaker |
| 10 | 3707429 | ON/OFF Rocker Switch (DPDT) |
| 11 | 3707434 | Square Unlight Push Button |
| 12 | 3707446 | Potentiometer Knob with Pointer |
| 13 | 3707564 | Green Start Push Button |
| 14 | 3707565 | Normaly Open (NO) Contact Block |
| 15 | 3707566 | Switch Mounting Latch |
| 16 | 3707567 | Push/Pull Red Emergency Stop Button |
| 17 | 3707568 | Normaly Closed (NC) Contact Block |
| 18 | 3707713 | ON/OFF/ON Momentary Rocker Switch |
| 19 | 4609082 | Control Panel Decal |
| 20 | 4609110 | Traverse Potentiometer Assembly |
| 21 | 4609512 | Electrical Panel Sub-Assembly (see page 48) |
| 22 | 4609568 | Control Panel Weldment |

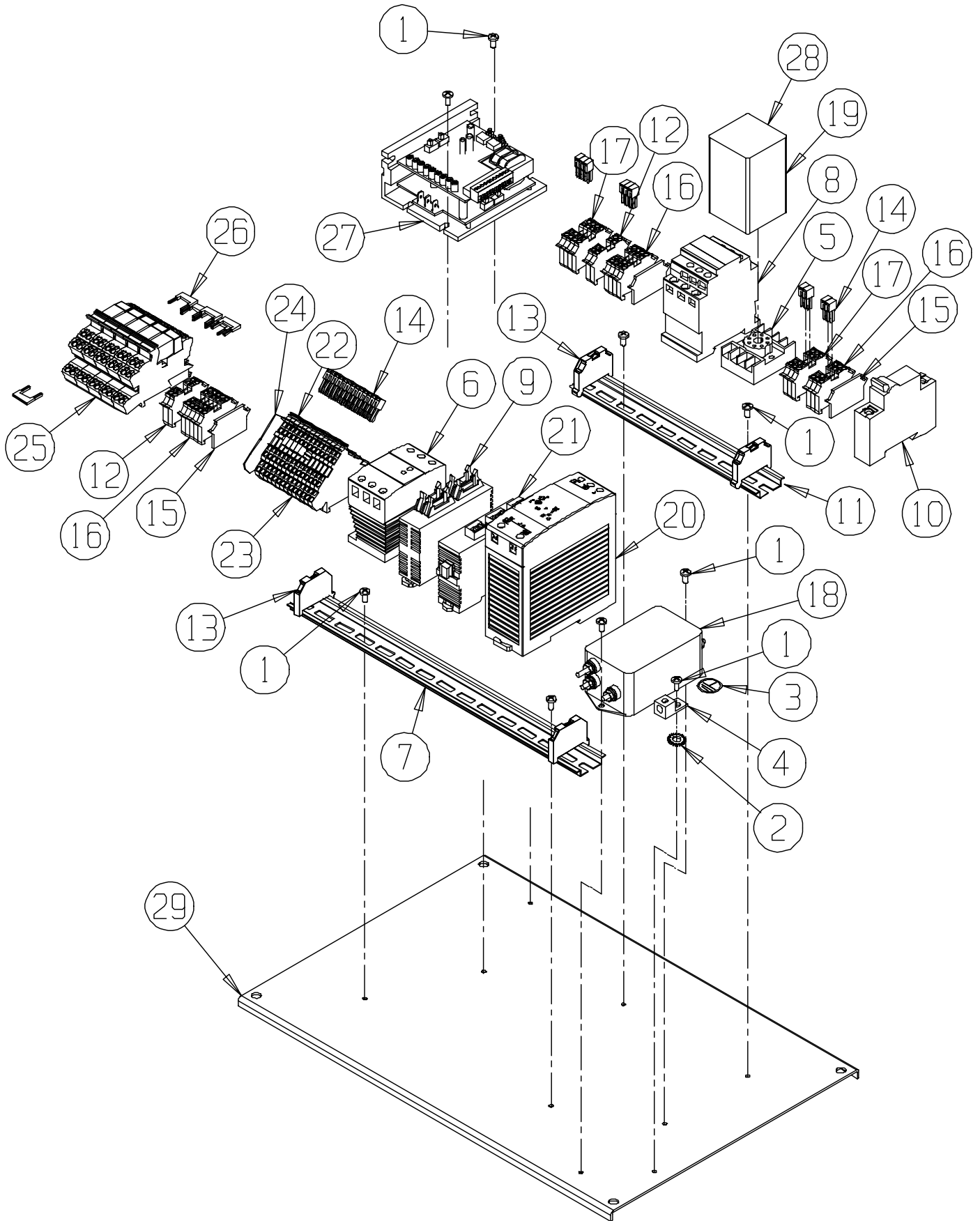

| <u>DIAGRAM NUMBER</u> | <u>PART NUMBER</u> | <u>DESCRIPTION</u> |
|---------------------------|------------------------|---|
| 1 | D160666 | #8 x 3/8" Long Phillips Pan Head Self Tapping Screw |
| 2 | R000480 | #8 Lock Washer |
| 3 | 3707163 | Primary Ground Decal |
| 4 | 3707164 | Primary Ground Lug |
| 5 | 3707073 | 8 Pin Socket |
| 6 | 3707333 | 24 VDC .3 Amp Power Supply |
| 7 | 3707378 | 14" Long Din Rail |
| 8 | 3707556 | 1 HP Magnetic Starter |
| 9 | 3707569 | Aromat PLC |
| 10 | 370589 | 15 Amp Circuit Breaker |
| 11 | 3707606 | 9" Long Din Rail |
| 12 | 3707624 | Ground Terminal Block |
| 13 | 3707625 | Screwless Terminal Block End Stops |
| 14 | 3707626 | Adjacent Terminal Block Jumper |
| 15 | 3707627 | Terminal Block End Plate |
| 16 | 3707628 | Grey 2-Conductor Terminal Block |
| 17 | 3707629 | Blue 2-Conductor Terminal Block |
| 18 | 3707654 | 20 Amp Line Filter |
| 19 | 3707688 | Low Voltage Relay (Low/High) |
| 20 | 3707682 | 24 VDC 60 Watt Power Supply |
| 21 | 3707683 | 2 Axis Stepper Drive |
| 22 | 3707684 | 3 Tier Terminal Block |
| 23 | 3707685 | 3 Tier Terminal Block w/LED |
| 24 | 3707686 | 3 Tier Terminal Block End Plate |
| 25 | 3707694 | Relay Terminal Block (8A - 24VDC) |
| 26 | 3707695 | 2 Pole Jumper - Wide |
| 27 | 3707697 | Traverse Drive |
| 28 | 3708920 | LVR Warning Decal (Low/High) |
| 29 | 4609079 | Electrical Sub Panel |
| | 4609097 | Stepper motor Cord |
| | 4609107 | Proximity Sensor Cord -Left |
| | 4609108 | Proximity Sensor Cord -Right |
| | 3707601 | Proximity Sensor |